





EXCELLENT SOLUTIONS IN FLUIDTECHNOLOGY

For over 45 years, Aignep has been a leading manufacturer of fluid and compressed air FITTINGS. Driven by a constant desire for innovation, our company has gained successful experience in various fields of industrial AUTOMATION with high quality and design products such as: cylinders, pneumatic valves, the "FLUIDITY" line with solenoid control valves for fluids, the "INFINITY" line for compressed air distribution, special fittings and QUICK COUPLING for any types of fluid.

All products are designed by a team of qualified engineers and they are manufactured in the production site of Bione, Italy, covering 25.000 m². We have over 14.000 standard items ex stock and countless special versions available on request.

Aignep invests every year in industrial automation, innovation and services to meet the worldwide customers' demands. In order to stay closer to our customers, our company has 11 branches spread around the globe: USA, Spain, France, Switzerland, Brasil, Colombia, China, Russian, Germany, Mexico and Vietnam becoming a multinational Group.

"Excellent solutions in fluidtechnology"

"Listening to our customers, understanding their needs is the power that drives us to develop everyday new solutions for fluid and compressed air".

GRAZIANO BUGATTI
CEO of Aignep





Aignep USA

In the mid-1990's, Aignep partnered with Aignep USA to expand into North America. The North American headquarters relocated in 2015 to a new, state-of-the-art facility in Fairview, TN. which also serves as a cylinder production site.

Over the past 20 years both Aignep and Aignep USA have experienced extensive growth and has resulted in the establishment of 9 locations throughout the world.

As Aignep's global footprint continues to expand it was strategically important to change the name from Alpha to Aignep USA.

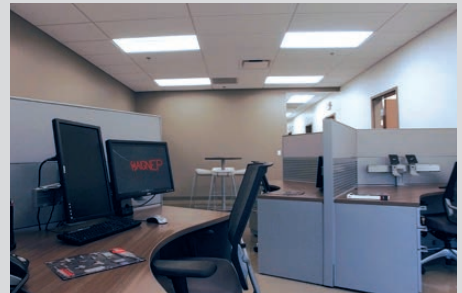

AIGNEP SPA - Headquarter

Via Don G. Bazzoli - 34
25070 Bione (BS)
ITALY

T: +39 0365 896626
F: +39 0365 896561

Fluidity division:

Via Archimede - 31
20864 Agrate Brianza (MB)
ITALY

aignep.it@aignep.com

AIGNEP USA LLC

7121 Loblolly Pine Blvd
Fairview, TN 37062
U.S.A.

T: +1 615 771 6650
F: +1 615 771 0926

aignep.usa@aignep.com

Sucursal:

Greater Toronto Area
CANADA

T: +1 647 473 6802
aignep.ca@aignep.com

AIGNEP IBERICA SA

Pol. Ind. el Tortuguer "Can Prat"
Naves 23 y 24 08691
Monistrol de Montserrat - Barcelona
SPAIN

T: +34 93 828 47 36
F: +34 93 828 44 32

aignep.es@aignep.com

AIGNEP FRANCE SARL

4 Rue des Prairies - 44840
Les Sorinières
FRANCE

T: +33 27 22 42 650

aignep.fr@aignep.com

AIGNEP (Wuxi) FLUID TECHNOLOGY CO., LT D.

NO. 8, Yanggong Road, Nanhu
Main Road, Wuxi Jiangsu.
CHINA

T: +86 0510 8544 1923
F: +86 0510 8540 0223

aignep.cn@aignep.com

AIGNEP RUS LLC.

Ryazansky prosp. h. 22, build.
2, office 723, 109428 - Moscow
RUSSIAN

T: +7 49 5143 6286

aignep.ru@aignep.com

Distribution network in:

ALBANIA ALGERIA ARGENTINE AUSTRALIA AUSTRIA AZERBAIGIAN BELARUS BELGIUM BOLIVIA BOSNIA
HERZEGOVINA **BRASIL** BULGARIA CAMEROON CANADA CHILE **CHINA** **COLOMBIA** COSTA RICA CROATIA CYPRUS
CZECH REPUBLIC DEM. REP. CONGO DENMARK ECUADOR EGYPT EIRE ESTONIA ETHIOPIA FINLAND **FRANCE**
GERMANY GHANA GREAT BRITAIN GREECE GUATEMALA HONG KONG HUNGARY ICELAND INDIA INDONESIA
IRAN IRAQ ISRAEL **ITALY** IVORY COAST JAPAN JORDAN KAZAKISTAN KUWAIT LATVIA LEBANON LITHUANIA

AIGNEP AG

Industriestrasse 22A
CH-2545 Selzach
SWITZERLAND

T: +41 32 342 09 09
F: +41 32 342 09 11

aignep.ch@aignep.com

AIGNEP DO BRASIL COMERCIO DE COMPONENTES PARA AUTOMAÇÃO LTDA

Rua Batista Pereira, 99 - Macuco
Vila Mathias - 11015-011 - Santos/SP
BRASIL

T: +55 13 2138 4049
F: +55 13 2138 4052

aignep.br@aignep.com

AIGNEP LATAM SAS

Sede:

Calle 15, N 27-78, Local 7
Sec. Paloquemao - 111411

Bogotá
COLOMBIA

T: +57 601 375 2501/8
T: +57 601 744 2086
T: +57 601 745 2736

Sucursal:

Carrera 50 FF, N 8 Sur - 27
Ofi 404 Edificio 8908 - 050023

Medellin
COLOMBIA

T: +57 46 04 25 34
T: +57 46 04 21 87

aignep.latam@aignep.com

AIGNEP DEUTSCHLAND GMBH

Sitz der Gesellschaft: 48739 Legden
Industriepark 2
GERMANY

T: +49 2566 7039 290
F: +49 2566 7039 299

aignep.de@aignep.com

AIGNEP MÉXICO S.A DE C.V.

Año de Juárez, 177 - 09070
Bodega 2, Granjas de San Antonio
Iztapalapa
MEXICO

T: +52 55 5686 1421
F: +52 55 5686 1575

aignep.mx@aignep.com

AIGNEP VIETNAM COMPANY LIMITED

No.5, Street 3, Lakeview City, Thu
Duc City Ho Chi Minh City
VIETNAM

T: +84 09 7369 4501

aignep.vn@aignep.com

LUXEMBOURG MALAYSIA MAROCCO **MEXICO** MOLDOVA NEW ZELAND NICARAGUA NIGERIA NORTH MACEDONIA
NORWAY OMAN PAKISTAN PERU PHILIPPINES POLAND PORTUGAL QATAR REPUBLIC OF DOMINICANA
REPUBLIC OF MACEDONIA ROMANIA **RUSSIAN** SAUDI ARABIA SENEGAL SERBIA SINGAPORE SLOVAKIA
SLOVENIA SOUTH AFRICA SOUTH KOREA **SPAIN** SWEDEN **SWITZERLAND** TAIWAN TANZANIA THAILAND
THE NETHERLANDS TUNISIA TURKEY UKRAINE UAE URUGUAY **USA** **VIETNAM** YEMEN

...more information at: sales@aignep.it

Certifications

ICIM

CERTIFICATO n. **0055/8**
 CERTIFICATE No. **0055/8**

SI CERTIFICA CHE IL SISTEMA DI GESTIONE PER LA QUALITÀ DI
 WE HEREBY CERTIFY THAT THE QUALITY MANAGEMENT SYSTEM OPERATED BY

AIGNEP S.P.A.
Sede e Unità Operativa
 Via Don Bazzoli, 34 - 25070 Bione (BS) - Italia
Direzione e uffici amministrativi, progettazione, produzione e montaggio, magazzino.
Unità Operativa
 Via Industriale, 1 - 25070 Bione (BS) - Italia
Montaggio e magazzino.

E' CONFORME ALLA NORMA / IS IN COMPLIANCE WITH THE STANDARD

UNI EN ISO 9001:2015
 Sistema di Gestione per la Qualità / Quality Management System
 PER LE SEGUENTI ATTIVITÀ / FOR THE FOLLOWING ACTIVITIES

EA: 17

Progettazione e fabbricazione di: raccordi, valvole a sfera per l'impiantistica pneumatica, oleodinamica ed idraulica; componenti per il trattamento dell'aria compressa (FRL); cilindri pneumatici; elettrovalvole pneumatiche e per fluidi; sistemi di distribuzione dell'aria compressa.

Design and production of: fittings, ball valves for pneumatic, hydraulic and plumbing applications; components for compressed-air treatment (FRL); pneumatic cylinders; pneumatic and fluid electromagnetic valves; distribution systems for compressed-air.

Refero alla documentazione del Sistema di Gestione per la Qualità secondo per l'applicazione del presente standard.

Il presente certificato è soggetto alle verifiche di conformità da parte di organismi di certificazione terzi.

The use and validity of the certificate shall comply with the requirements of the ICIM document (Book for the certificate of compliance management system) and applicable Scheme.

The information provided is subject to external control by independent bodies for certification of the management system.

Il presente certificato è valido fino al 31/12/2025 a meno che non venga rinnovato.

For filing and updated information about any changes, the certificate holder, refer to this website, please contact the number +39 02 75341 or email address info@icim.it

Data emissione / First issue	11/12/1992	Emisione corrente / Current issue	11/09/2018	Data di scadenza / Expiry date	17/05/2020
------------------------------	------------	-----------------------------------	------------	--------------------------------	------------

ICIM S.p.A.
 Piazza Don Enrico Minardi, 15 - 20020 Sesto San Giovanni (MI)
 www.icim.it

ACCREDIA

CISQ

FEDERAZIONE CISQ

IQNet
 THE INTERNATIONAL CERTIFICATION NETWORK

CERTIFICATE

CISQ/ICIM SPA has issued an IQNet recognized certificate that the organization:

AIGNEP S.P.A.
Head Office and Operative Unit
 Via Don Bazzoli, 34 - I-25070 Bione (BS)
Operative Unit
 Via Industriale, 1 - I-25070 Bione (BS)

has implemented and maintains a
Quality Management System
 for the following scope:

Design and production of: fittings; ball valves for pneumatic, hydraulic and plumbing applications; components for compressed-air treatment (FRL); pneumatic cylinders; pneumatic and fluid electromagnetic valves; distribution systems for compressed-air.
 which fulfils the requirements of the following standard:

ISO 9001:2015
 Issued on: **2018-09-11**
 First issued on: **1992-12-11**
 Expires on: **2020-09-17**

This attestation is directly linked to the IQNet Partner's original certificate and shall not be used as a stand-alone document.

Registration Number: **IT-3755**

Alex Stoichitoiu
 President of IQNET

Ing. Claudio Provetti
 President of CISQ

IQNet Partners*
 AENOR Spain AFNOR Certification France APCER Portugal CVC Cyprus CISQ Italy
 CQC China CCM China CQS Czech Republic Cst Cert Croatia DQS Holding GmbH Germany FCVY Brazil
 FONDONORMA Romania ISONET Colombia Inspecta Seritrolite Oy Finland INTCO Costa Rica
 IRAM Argentina IIA Japan KIFU Korea MIBETEC Greece MSZT Hungary Nemko AS Norway NSAI Ireland
 NVCS-SICE Mexico PCPC Poland Quality Austria Austria ER Bureau SII Bureau SQA Slovenia
 SIRIM QAS International Malaysia SGS Switzerland SRAC Romania TEST ST Petersburg Russia TSE Turkey YUQS Serbia
 IQNet is represented in the USA by: AFNOR Certification, CISQ, DQS Holding GmbH and NSAI Inc.

* The list of IQNet partners is valid at the time of issue of this certificate. Updated information is available under www.iqnet-certification.com

Technická inšpekcia, a.s.
 Tvravská cesta 56, 621 01 Bratislava, Slovenská republika

ACKNOWLEDGEMENT OF RECEIPT
 no. 1488/1/2022

Technická inšpekcia, a.s.,
 Tvravská cesta 56, 621 01 Bratislava
 Notified body 1354,
confirms, that Technical File Documentation
 assigned by
AIGNEP S.p.A.
 Via Don G. Bazzoli 34, 25070 Bione (BS), Italy

has been received and stored according to the Article 10, 1(b) (i) of Directive no. 2014/54/EU on equipment and protective systems intended for use in potentially explosive atmospheres.

Scope of Ex (Equipment):
 Fluid Solenoid Actuated Valves
 Type:
 81F, 82F, 83F, 84F, X1F, X2F, X3F, F1F, F2F, 85F, K3F, 02A, X2A, X3A, 04A, X4A, X3F

Marking:
 82 0 Ex A IIB T4, T3 Ex 0°C/Tamb=60°C
 12 0 Ex n IIB TExC, -200°C D0-10°C/Tamb=60°C

Technical File Documentation according to the Annex VIII Article 2 of Directive 2014/54/EU

Documents:
 Issue: **Issue 03, Rev 03**
 Technical Book n° 3/2022
 Date of issue: **21.3.2022**

Technical documentation will be stored for 10 years until May 18th, 2032.

On behalf of Technická inšpekcia, a.s.
 General Director

EURO CERT

CERTIFICATE No. EURCERT 23 ATEX 024

CERTIFICATE OF RECEIPT OF TECHNICAL DOCUMENTATION
 According Equipment or protective systems intended for use in potentially explosive atmospheres under DIRECTIVE 2014/54/EU

Manufacturer: **AIGNEP SPA**
 (Name & Address): **VIA DON GIUSEPPE BAZZOLI N. 34-25070 BIONE - BRESCIA - ITALY**
 TCF No.: **TCF-411-2023/026**
 Product Description: **Angle Seat Valve, Pneumatic Shutoff Valve, Check Valve, Strainer,**
 Model(s): **Pressure Reducing Valve, Steam Trap, Diaphragm Valve**
 Apparatus Marking: **DNE-130**

EX II 2G/D h T4

Eurocert S.A., is Notified Body 1128, hereby acknowledges that the manufacturer has fulfilled its duties concerning communication of the dossier of technical documentation to a Notified Body in accordance with the requirements of Directive 2014/54/EU, Article 13, 1. (B) (3).

If the manufacturer makes any changes to the Technical Documentation mentioned above, this certificate becomes invalid. Possible additions or modifications to the stored Technical Documentation shall be acknowledged by a future revision of the Certificate.

Date issued: **20/09/2023**
 Valid until: **19/09/2033**

VDE Prüf- und Zertifizierungsinstitut

ZEICHGENEGENHIMUNG MARKS APPROVAL

Alignep s.p.a.
 VIA DON GIUSEPPE BAZZOLI 34
 25070 BIONE BS
 Italy

ist bewirkt, für ihr Produkt / is authorized to use for their product
Elektrisch betriebene Ventile
Electrically operated valve

die hier abgebildeten markenrechtlich geschützten Zeichen / the use of the listed Trademark Types is beneficial if the legally protected Marks as shown below for the types referred to on page 2 if

Copyright and certified mark /
 Tested and certified according to

DN EN 60754-1 VDE 0621-10:2021-06 EN 60754-1:2014-03:2019
 EN 60754-2:2014-03:2022
 Abschnitte / subsections 7.6-8-9-10-11-12-13-14-15-16-17-18-20-21-27
 The product also falls into the responsibility of

EN 60754-1:2014-03:2019
 EN 60754-2:2014-03:2022
 Abschnitte / subsections 7.6-8-9-10-11-12-13-14-15-16-17-18-20-21-27

Attestationsnr.: 0137984-4330-0001 | 323544
 File n°:
 VCE Prüf- und Zertifizierungsinstitut GmbH
 VDE Testing and Certification Institute
 Zertifizierungsinstitut / Certification
 Offenbach, 2025-11-19

VDE



| Services

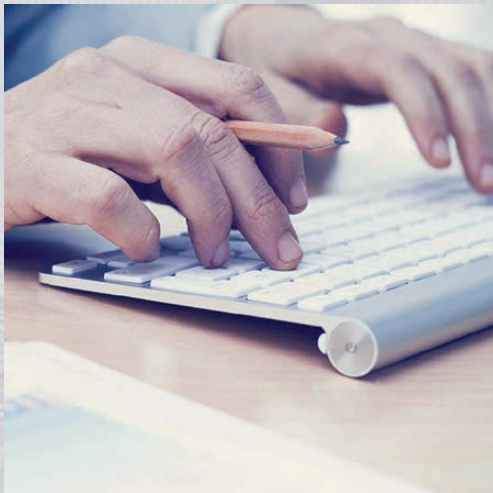

MYAIGNEP

Your documents online



AIGNEP
SCAN

Your orders in one click



Catalogues

Our catalogues at your disposal

0. Introduction

HOW TO READ THE NEW FLUIDITY CATALOG	Pag 0.1- 0.3
INTRODUCTION AND FUNCTION - SOLENOID VALVE TYPES	Pag 0.4 - 0.6
GENERAL TECHNICAL INFORMATION	Pag 0.7
FLOW COEFFICIENTS Kv and Cv - VISCOSITY	Pag 0.7
FLOW CALCULATION - IP PROTECTION CLASS	Pag 0.8 - 0.9
COILS TECHNICAL INFORMATION	Pag 0.10
CONVERSION TABLES TEMPERATURE - PRESSURE - STEAM VALUES	Pag 0.10 - 0.11
RESPONSE TIMES	Pag 0.12
CHEMICAL COMPATIBILITY TABLE - SEALING MATERIALS FEATURES - INSTALLATION AND MAINTENANCE	Pag 0.13 - 0.14

1. Series 01F 2/2 NC-NO - 3/2 NC-NO - 2/2 LATCHING

DIRECT ACTING SOLENOID VALVES WITH BRASS BODY

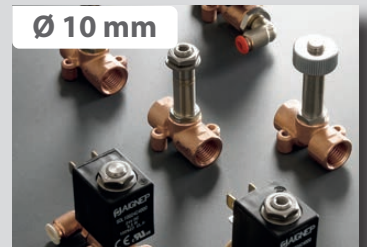

2. Series X1F 2/2 NC-NO - 3/2 NC-NO - 2/2 LATCHING

DIRECT ACTING SOLENOID VALVES WITH STAINLESS STEEL 316L BODY



3. Series F1F 2/2 NC-NO - 3/2 NC-NO - 2/2 LATCHING

DIRECT ACTING SOLENOID VALVES WITH FLANGE FIXING AND BRASS CW510L BODY

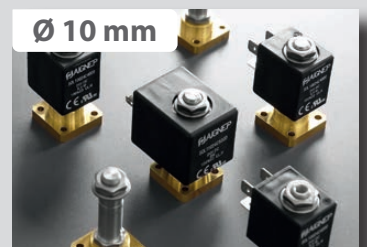

4. Series A1M 2/2 NC

DIRECT-ACTING SOLENOID VALVES WITH ALUMINUM BODY



5. Series 02F 2/2 NC-NO - 3/2 NC-NO

DIRECT ACTING SOLENOID VALVES WITH BRASS BODY



6. Series X2F 2/2 NC-NO - 3/2 NC-NO

DIRECT ACTING SOLENOID VALVES WITH STAINLESS STEEL 316L BODY

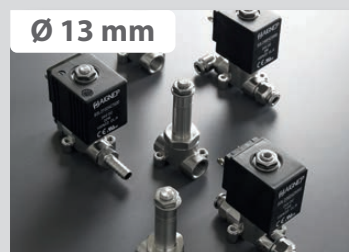

7. Series F2F 2/2 NC-NO - 3/2 NC-NO

DIRECT ACTING SOLENOID VALVES WITH FLANGE FIXING AND BRASS CW510L BODY

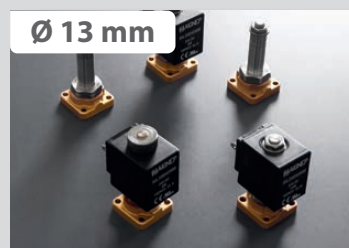

8. Series 03F 2/2 NC

GUIDED DIAPHRAGM SOLENOID VALVES WITH BRASS BODY



9. Series 04F 2/2 NC-NO - 2/2 LATCHING

SERVO-ASSISTED SOLENOID VALVES WITH BRASS BODY

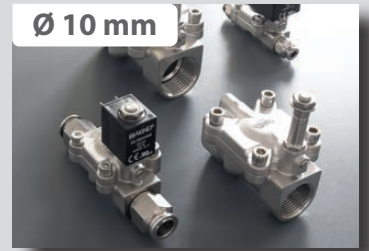
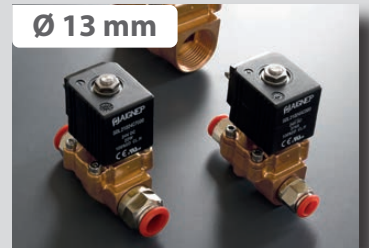
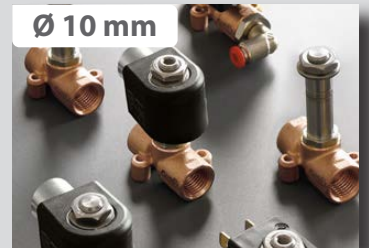
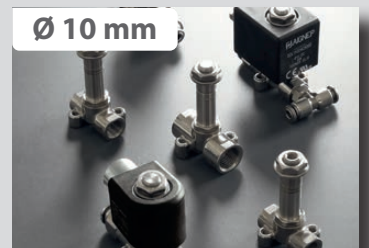
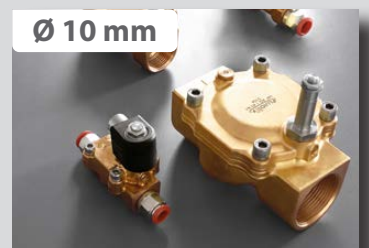

10. Series X4F 2/2 NC-NO - 2/2 LATCHING**SERVO-ASSISTED SOLENOID VALVES WITH STAINLESS STEEL 316L BODY****Ø 10 mm****11. Series 06F 2/2 NC ΔP = 0 psi****ASSISTED-LIFT DIAPHRAGM SOLENOID VALVES****Ø 13 mm****12. Series X6F 2/2 NC ΔP = 0 psi****ASSISTED-LIFT DIAPHRAGM SOLENOID VALVES IN STAINLESS STEEL 316L****Ø 13 mm****13. Series 01C 2/2 NC-NO - 3/2 NC-NO****DIRECT ACTING SOLENOID VALVES WITH BRASS BODY****Ø 10 mm****13. Series X1C 2/2 NC-NO - 3/2 NC-NO****DIRECT ACTING SOLENOID VALVES WITH STAINLESS STEEL 316L BODY****Ø 10 mm****13. Series 04C 2/2 NC-NO****SERVO-ASSISTED SOLENOID VALVES WITH BRASS BODY****Ø 10 mm**

13. Series X4C 2/2 NC-NO

SERVO-ASSISTED SOLENOID VALVES WITH STAINLESS STEEL 316L BODY

Ø 10 mm



14. Series 90976 2/2 NC

DRAIN VALVE

Ø 13 mm

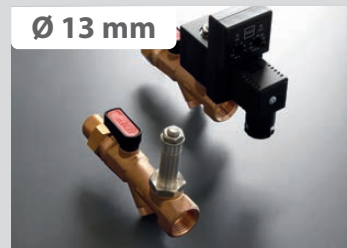

15. Coils & Connectors

COILS AND CONNECTORS



16. Accessories & Solenoid Pilots

FLUIDITY SPARE PARTS AND ACCESSORIES



Fluidity Series

Aignep, Italian company leader in the production of components for fluid controls, designs and manufactures the range of FLUIDITY solenoid valves for the use with liquid and gaseous fluids.

With a simple and compact design, the FLUIDITY solenoid valves are available in 2/2 and 3/2 versions, direct acting and servo-assisted, NC and NO, sizes from 1/8" up to 2" and the whole range is ATEX II 2G/D Ex h certified.

The bodies are available in different types of brass and Stainless Steel, with a wide selection of gaskets depending on the compatibility with the fluid.





The materials used allow the FLUIDITY solenoid valves to be installed also in food applications or in contact with aggressive fluids and reach working temperatures from -40°C to +180°C.

The proposed coils allow to obtain high performances and, on request, low power consumption.

Multiple are the combinations with our fittings depending on the application and the fluid to be managed.

In addition to the standard products in the catalog, we are able to realize customized solutions to satisfy the most demanding requests of our Customers.

Main advantages

- Simple, compact and strong design
- ATEX II 2G / D Ex h certified valves
- High pressures and high flow rates
- High quality gaskets: perfect sealing with high number of working cycles
- Class H coils
- Coils certified  -  -  - 
- Products traceability
- Stock availability for quick delivery
- 100% Made in Italy

Applications

- Food industry
- Coffee & vending
- Irrigation
- Industrial Processes and Automation
- Machine tools, Laser cutting
- Automotive
- Compressors
- Industrial washing, pressure washers
- Car wash
- Misting
- Heating and Refrigeration
- Medical
- Sterilizers
- Vacuum
- Chemical and Petrochemical industry
- Fire-fighting systems

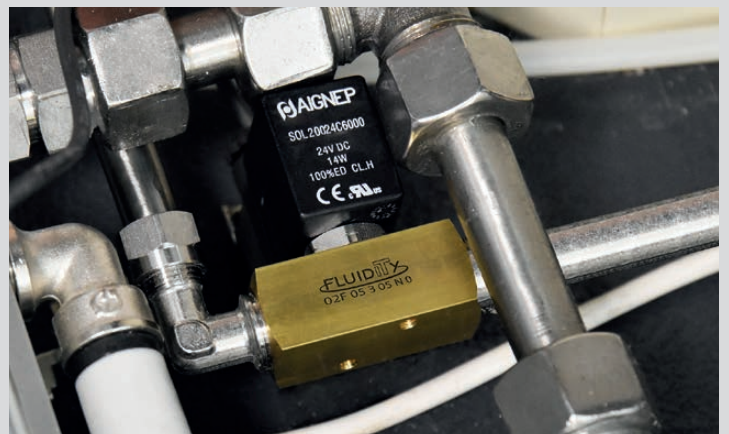
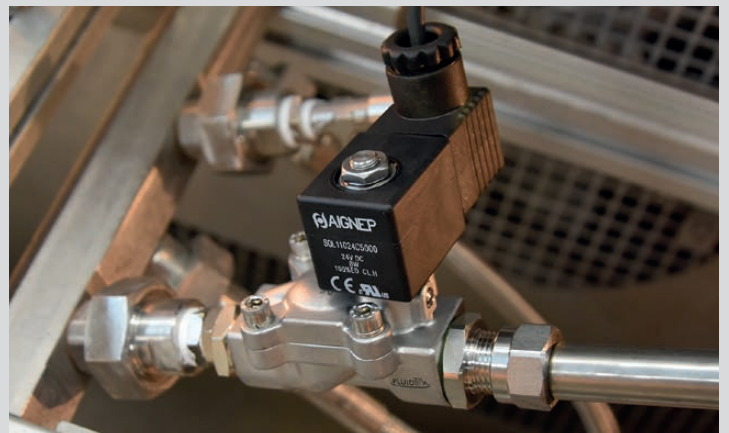
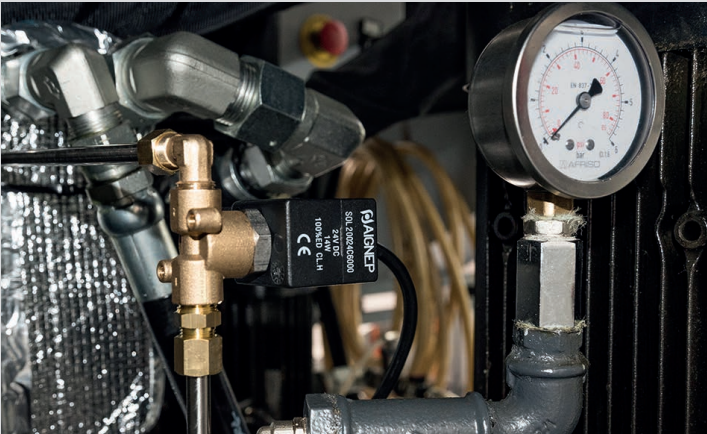
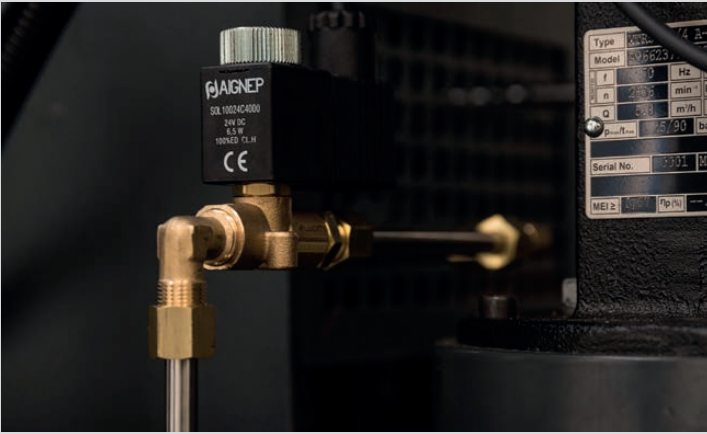

SOLENOID VALVES FOR FLUIDS



Series Fluidity

HOW TO READ THE FLUIDITY CATALOG

Introduction to the catalog

The Fluidity catalog includes all the families of solenoid valves for fluid controls available in the Aignep's product range.

In the catalog the User can find technical content, information, tables and formulas in the introduction pages, whereas for each individual Series, a product presentation it's proposed including technical features, certifications, available options and improved performances.

In order to offer an increasingly excellent service and support to its Customers, Aignep reserves the right to make changes to the catalog to improve products and contents, and recommends to contact the technical support for any necessary clarification.

°F	°C	K	°F	°C	K	°F	°C	K
-40	-40	233.15	104	40	313.15	284	140	413.15
-31	-35	238.15	113	45	318.15	302	150	423.15
-22	-30	243.15	122	50	323.15	320	160	433.15
-13	-25	248.15	131	55	328.15	338	170	443.15
-4.0	-20	253.15	140	60	333.15	356	180	453.15
5.0	-15	258.15	149	65	338.15	374	190	463.15
14	-10	263.15	158	70	343.15	392	200	473.15
23	-5	268.15	167	75	348.15	428	220	493.15
32	0	273.15	176	80	353.15	464	240	513.15
41	5	278.15	185	85	358.15	500	260	533.15
50	10	283.15	194	90	363.15	536	280	553.15
59	15	288.15	203	95	368.15	572	300	573.15
68	20	293.15	212	100	373.15	662	350	623.15
77	25	298.15	230	110	383.15	752	400	673.15
86	30	303.15	248	120	393.15	842	450	723.15
95	35	308.15	266	130	403.15	932	500	773.15

FLUIDS	Sealing materials				
	Brass	Stainless Steel AISI 316L	NBR	EPDM	FKM
Acetone	●	●	●	●	●
Acetylene	●	●	●	●	●
Argon	●	●	●	●	●
Benzene	●	●	●	●	●
Butane	●	●	●	●	●
Carbon dioxide dry (gas)	●	●	●	●	●
Carbon dioxide dry (liquid)	●	●	●	●	●
Carbon disulfide	●	●	●	●	●
Chloroform (100%)	●	●	●	●	●
Diesel fuel	●	●	●	●	●
Helium	●	●	●	●	●
Ethane	●	●	●	●	●
Ethanol	●	●	●	●	●
Ethyl acetate	●	●	●	●	●
Ethyl chloride	●	●	●	●	●

Sealing materials	Temperature		Fluids
	min	max	
NBR	+14°F	+194°F	Air, Inert gases, water, mineral oils, diesel, fuel oils
NBR ❄️	-40°F	+194°F	Air, Inert gases, water, mineral oils, diesel, fuel oils
FKM	+14°F	+284°F	Mineral oils, gasoline, diesel, fuel oils
EPDM	+14°F	+284°F	Hot water, steam (max pressure 36 psi)
PTFE	-40°F	+356°F	Steam (max pressure 145 psi), solvents, aggressive fluids
RUBY	-40°F	+356°F	Water, hot water, demineralized water, steam (max pressure 145 psi), aggressive fluids

Product presentation

In the introduction pages for each valve Series, a brief presentation of the product is proposed which introduces the type of valve and shows the main data to simplify the choice; the pages offer the following information:

- 1 Product family, valve function and available port sizes.
- 2 Materials and components, general features and helpful information.
- 3 How to compose the valve model and explanation of each individual code.
- 4 Usable coils and connectors, with reference to the technical data sheets pages.

Valve section

Following the product presentation, there are the pages related to the types of valves expected for the Series in question; on these pages is possible to find the following information:

- 5 Valve codes table showing technical features and performances, divided according to the type of coil.
- 6 Complete the valve code indicated in the first column with the letter relating to the available sealing material indicated in the second column.
- 7 Valve sectional and dimensional drawing.

Series 01F

DIRECT ACTING SOLENOID VALVES WITH BRASS BODY

2/2 NC

1/8" - 1/4"

Series 01F - 2/2 NC

Component Parts and Materials

- 1 Body: Brass CW617N
- 2 Seals: NBR - EPDM - FKM
- 3 Armature tube: Stainless steel
- 4 Fixed and mobile core: Stainless steel AISI 430FR
- 5 Springs: Stainless steel

General features - 01F

- Universal mounting position
- Operator kit Ø 10 mm
- ATEX II 2GD Ex certification
- Coils: Class H - - CSA C22.2

Maximum allowable pressure

580 psi (40 bar)

Compatibility and materials table

Page 0.13 - 0.14

Room temperature with coil class H

+14°F	+176°F
-10°C	+80°C

Applications

- Water, Neutral liquids, Oils
- Food industry, Coffee & vending
- Air, Inert gases, Vacuum
- Industrial processes, Automation
- Machine tools, Laser cutting, Compressors
- Oxygen, Steam, Medical
- Chemical and Petrochemical industry

Series 01F - 2/2 NC

Code	Sealing materials	Port size	Ø Orifice	Viscosity	Cv	Differential pressure (OPD)			Power		Coils							
						psi (bar)			DC	AC	Size	Series						
						Min	Max DC	Max AC					W	VA	mm			
01F 02 1 15 0 N	N = NBR +14°F +176°F -10°C +80°C	NPTF	1/8"	25	0.07 (0.06)	0	232 (16)	435 (30)	6.5	7.5	22	A - SOL10						
580 (40)							580 (40)	8	11	30	B - SOL11							
01F 02 1 02 0 N							174 (12)	363 (25)	6.5	7.5	22	A - SOL10						
435 (30)							580 (40)	8	11	30	B - SOL11							
01F 02 1 25 0 N							65 (4.5)	261 (18)	6.5	7.5	22	A - SOL10						
189 (13)							435 (30)	8	11	30	B - SOL11							
01F 02 1 03 0 N							44 (3)	145 (10)	6.5	7.5	22	A - SOL10						
102 (7)							232 (16)	8	11	30	B - SOL11							
01F 02 1 04 0 N							15 (1)	58 (4)	6.5	7.5	22	A - SOL10						
36 (2.5)							116 (8)	8	11	30	B - SOL11							
01F 03 1 15 0 N							E = EPDM +14°F +176°F -10°C +80°C	NPTF	1/4"	37	0.10 (0.09)	0	232 (16)	435 (30)	6.5	7.5	22	A - SOL10
580 (40)													580 (40)	8	11	30	B - SOL11	
01F 03 1 02 0 N	174 (12)	363 (25)	6.5	7.5	22	A - SOL10												
435 (30)	580 (40)	8	11	30	B - SOL11													
01F 03 1 25 0 N	65 (4.5)	261 (18)	6.5	7.5	22	A - SOL10												
189 (13)	435 (30)	8	11	30	B - SOL11													
01F 03 1 03 0 N	44 (3)	145 (10)	6.5	7.5	22	A - SOL10												
102 (7)	232 (16)	8	11	30	B - SOL11													
01F 03 1 04 0 N	15 (1)	58 (4)	6.5	7.5	22	A - SOL10												
36 (2.5)	116 (8)	8	11	30	B - SOL11													

① Select seal material
With steam: EPDM - P max = 36 psi (2.5 bar)
Coil not included

Series 01F - 2/2 NC

Max: 3.685 ft-lbs

Size	A	B	C	D	E	F	G
	inch (mm)	inch (mm)	inch (mm)	inch (mm)	inch (mm)	inch (mm)	inch (mm)
1/8"	1.228 (31.2)	2.090 (53.1)	1.019 (25.9)	0.708 (18)	0.492 (12.5)	0.255 (6.5)	M8 x 0.75
1/4"	1.456 (37)	2.208 (56.1)	1.141 (29)	0.826 (21)	0.472 (12)	0.236 (6)	M8 x 0.75

Ordering codes

Series	Port size	Functions	Orifice	Sealing materials	Version	Thread	Suitable coils
01F021150N	02 = 1/8" 03 = 1/4"	1 = 2/2 NC	15 = 1/16 (1.5) 02 = 5/64 (2) 25 = 3/32 (2.5) 03 = 1/8 (3) 04 = 5/32 (4)	N = NBR E = EPDM V = FKM	0 = Standard	N = NPTF	A = A series - SOL10 B = B series - SOL11 A = 12V DC B = 24V DC 1 = 24V AC 2 = 110V AC 3 = 220V AC

Valves and coils are supplied separately. Upon commercial agreements can be supplied assembled.

COILS: SERIES A, B

PAGE: 11.2 / 11.3

CONNECTORS

PAGE: 11.7

Series 01F - 2/2 NC

Series 01F - 2/2 NC

Ordering codes

Series	Port size	Functions	Orifice	Sealing materials	Version	Thread	Suitable coils
01F021150N	02 = 1/8" 03 = 1/4"	1 = 2/2 NC	15 = 1/16 (1.5) 02 = 5/64 (2) 25 = 3/32 (2.5) 03 = 1/8 (3) 04 = 5/32 (4)	N = NBR E = EPDM V = FKM	0 = Standard	N = NPTF	A = A series - SOL10 B = B series - SOL11 A = 12V DC B = 24V DC 1 = 24V AC 2 = 110V AC 3 = 220V AC

Valves and coils are supplied separately. Upon commercial agreements can be supplied assembled.

COILS: SERIES A, B

PAGE: 11.2 / 11.3

CONNECTORS

PAGE: 11.7

1.2

1.3

0.2

Coil section

Each valve requires the use of certain types of coils, as indicated for each Series. The pages related to each coil Series contain the following information:

- 11 Product family, coil sectional and dimensional drawing.
- 12 Coil codes table with the main technical features: available voltages supply, standard powers, tolerances and ambient temperature.
- 13 General technical information and options on request.
- 14 Coil size, operator diameter and ED service.
- 15 Standard certifications.
- 16 Reference with 2 digits and related coil code.

AIGNEP
Serie A

SERIES A
COIL 11

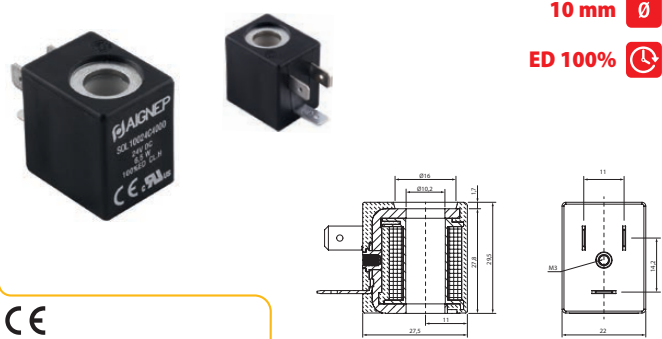

22 mm

10 mm

ED 100%

CE
C **UL** **US**
UL 429 & CSA C22.2 NO. 139-13

12

Reference	Code	Voltage	Power	Voltage tolerance	Ambient temperature	
					Min	Max
AA	SOL10012C4000	12V DC	6.5 W	±10 %		
AB	SOL10024C4000	24V DC	6.5 W	±10 %		
A1	SOL10024A8000	24V AC / 50-60 Hz	7.5 VA	±10 %	+14°F (-10°C)	+176°F (+80°C)
A2	SOL10110A8000	110V AC / 50-60 Hz	7.5 VA	±10 %		
A3	SOL10220A8000	220V AC / 50-60 Hz	7.5 VA	±10 %		

INSULATION CLASS: **H** EN 60085

ENCAPSULATION MATERIAL: RYNITE*

ELECTRICAL CONNECTIONS: FORM B EN 175301-803 (EX DIN 43650)

13

AMBIENT TEMPERATURE: +14°F +176°F (-10°C +80°C)

PROTECTION DEGREE: IP67 IEC 60529 with connector IP67

OPTIONS: Other voltages/powers on request

AIGNEP
Series B

SERIES B
COIL 14

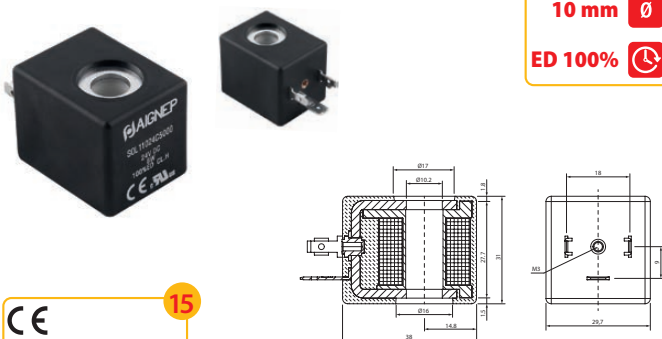

30 mm

10 mm

ED 100%

CE
C **UL** **US**
UL 429 & CSA C22.2 NO. 139-13

15

Reference	Code	Voltage	Power	Voltage tolerance	Ambient temperature	
					Min	Max
BA	SOL11012C5000	12V DC	8 W	±10 %		
BB	SOL11024C5000	24V DC	8 W	±10 %		
B1	SOL11024A9000	24V AC / 50-60 Hz	11 VA	±10 %	+14°F (-10°C)	+176°F (+80°C)
B2	SOL11110A9000	110V AC / 50-60 Hz	11 VA	±10 %		
B3	SOL11220A9000	220V AC / 50-60 Hz	11 VA	±10 %		

INSULATION CLASS: **H** EN 60085

ENCAPSULATION MATERIAL: RYNITE*

ELECTRICAL CONNECTIONS: FORM A EN 175301-803 (EX DIN 43650)

16

AMBIENT TEMPERATURE: +14°F +176°F (-10°C +80°C)

PROTECTION DEGREE: IP67 IEC 60529 with connector IP67

OPTIONS: Other voltages/powers on request



Introduction and function

Solenoid valves are electromechanical devices which allow a fluid, either gaseous or liquid, to flow through an orifice inside the valve body. The opening or closing of the main orifice, whether controlled directly or indirectly, takes place via the mobile plunger which is activated by the magnetic field generated by the coil.

Technical elements and terminology

The solenoid valves are composed by:

- 1 Valve body, in which there is the main orifice and the inlet/outlet connections to the line.
- 2 Operator kit, composed by an armature tube (which houses the fixed core) and mobile core (which houses the shutter). Generating the magnetic field, the mobile plunger slides inside the armature tube allowing the opening or closing of the main orifice or the pilot orifice or the exhaust (in the case of a 3-way valves).
- 3 Coil or solenoid, which generates the magnetic field needed to activate the mobile plunger.
- 4 Diaphragm or piston (for servo-assisted valves only), which allows the opening or closing of the main orifice.
- 5 Cover (for servo-assisted valves only), which has the function of housing the operator kit and being installed on the body to allow the fluid to flow inside the valve.

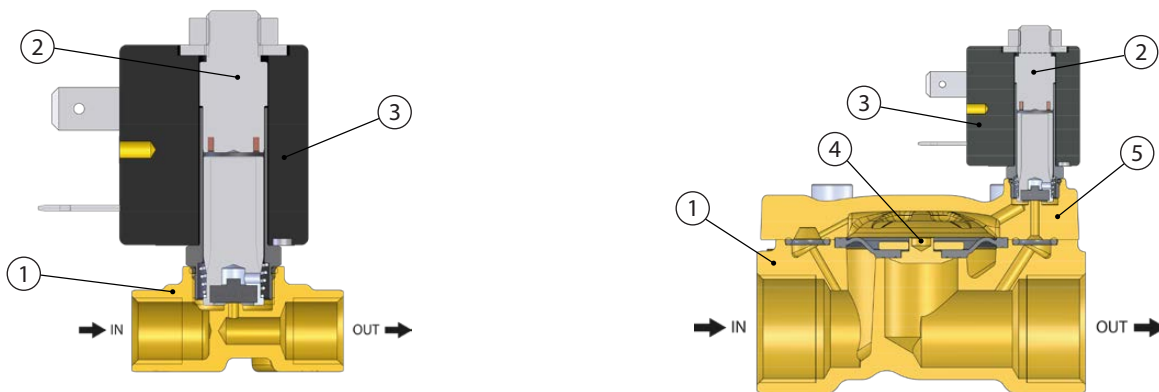

Solenoid valve types

DIRECT ACTING SOLENOID VALVES

2/2 NC - NO

3/2 NC - NO

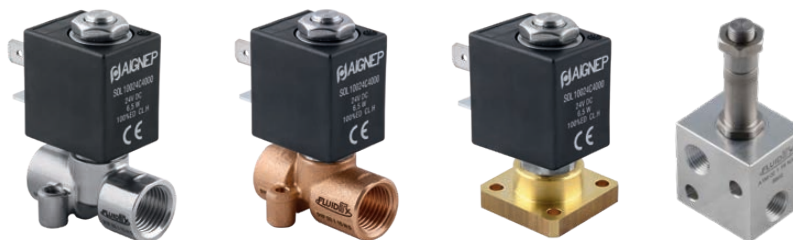

1

SERVO-ASSISTED SOLENOID VALVES

2/2 NC - NO



2

GUIDED DIAPHRAGM SOLENOID VALVES $\Delta p = 0$ psi

2/2 NC



3

DIRECT ACTING SOLENOID VALVES

2/2



Direct acting 2/2 - NC / NO / Latching

In the 2/2-way direct acting solenoid valves, available in Normally Closed or Normally Open versions, the mobile plunger opens or closes the main orifice of the valve. These type of valves work also with a minimum OPD zero bar up to a maximum OPD which varies according to the model and the power of the coil. In both cases (NC or NO), the functioning is determined by the magnetic field generated by the current in the coil. In 2/2 Latching valves, the switching is done by sending an electrical pulse of at least 20ms duration with polarity inverted compared to the previous pulse.

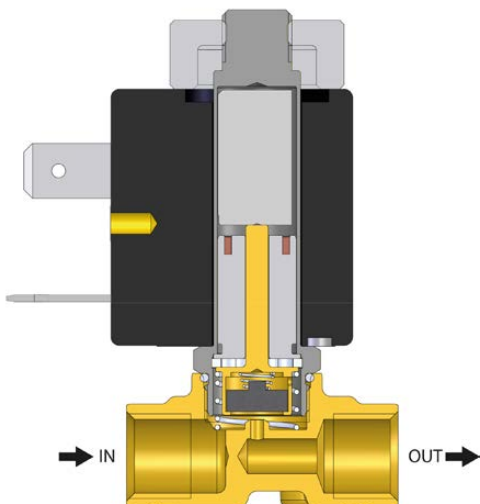
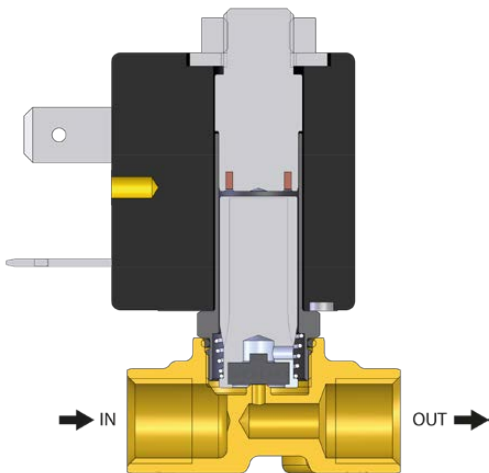

DIRECT ACTING SOLENOID VALVES

3/2



Direct acting 3/2 - NC and NO

The 3/2-way direct acting solenoid valves have inlet and outlet connections carved/machined from in the valve body and an exhaust connection carved/machined from in the fixed core. The main and the exhaust orifices are intercepted by the shutters present in the mobile plunger.

These valves are available in the Normally Closed or Normally Open versions and can operate with a minimum OPD of zero bar up to a maximum OPD which varies according to the model. In the NC version's, in rest position the outlet and exhaust are in communication with each other, while the incoming fluid is intercepted by the shutter. By energizing the coil, the main orifice is opened and the fluid can flow from the inlet to the outlet; the exhaust is closed. In the NO version's, in rest position the main orifice is open and the fluid can flow from the inlet to the outlet, while the exhaust is closed. By energizing the coil the main orifice is closed and the outlet is in communication with the exhaust which is opened. In both cases the functioning is determined by the magnetic field generated by the passing electric current in the coil.

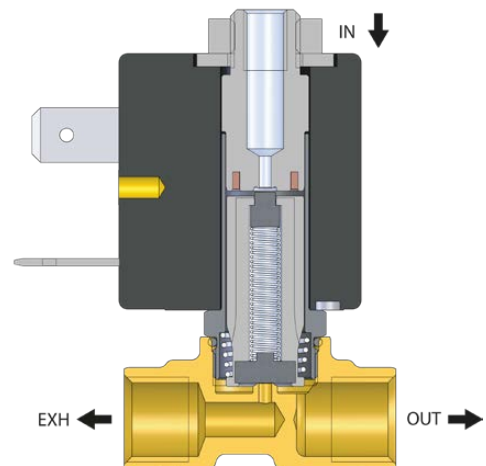
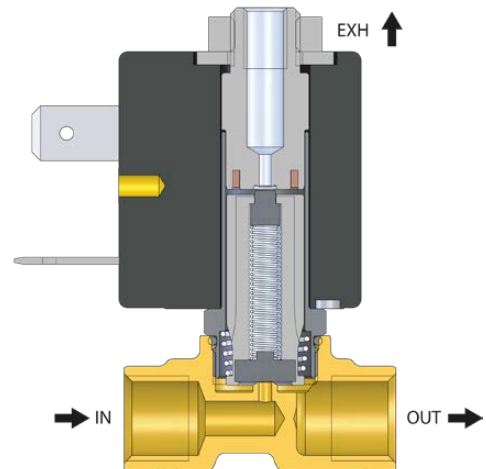

SERVO-ASSISTED OR INDIRECT ACTING SOLENOID VALVES



Servo-assisted 2/2 - NC / NO / Latching

In the servo-assisted solenoid valves, available in the 2/2-way Normally Closed or Normally Open versions, the main feature is the possibility to manage high flow rates compared the direct acting valves, while the fluid is intercepted by the diaphragm or by the piston which acts on the main orifice.

In these types of valves the opening or closing of the main orifice is determined by the min OPD, generated between the inlet and the outlet, which allows the movement of the diaphragm or piston.

By energizing the coil the mobile plunger opens or closes the pilot orifice causing the relieve or the load of the fluid that acts in the top chamber of the diaphragm or piston, generating an imbalance of forces (Δp) able to allow the movement of the diaphragm or piston and therefore the opening or closing of the main orifice.

The functioning of the servo-assisted valves depends both from the magnetic field generated by the coil for controlling the pilot orifice and from the min OPD required for opening/closing the diaphragm or piston.

In 2/2 Latching valves, the switching is done by sending an electrical pulse of at least 20ms duration with polarity inverted compared to the previous pulse.

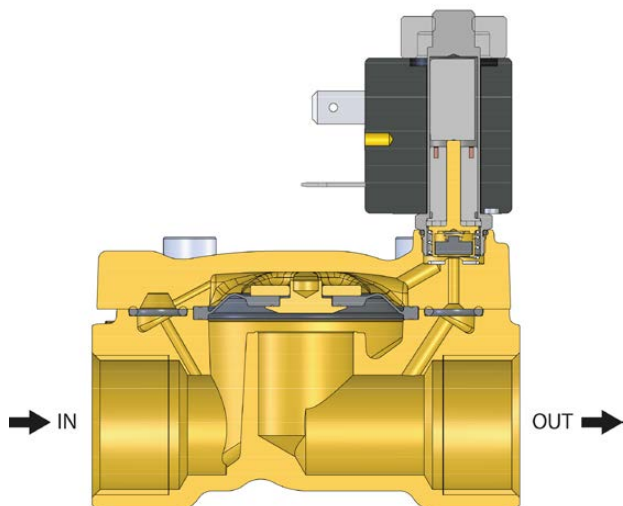
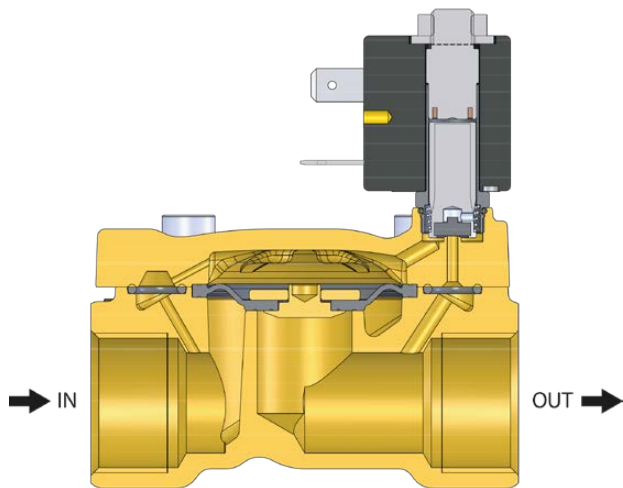

MIXED ACTING SOLENOID VALVES



Mixed acting 2/2 - NC

The mixed acting solenoid valves, available in the 2/2-way Normally Closed version, are the combination of direct acting and servo-assisted valves.

In these valves the mobile plunger is mechanically connected to the diaphragm, in which the pilot orifice is in.

By energizing the coil, the mobile plunger opens the pilot orifice (releasing the pressure present in the top chamber of the diaphragm) and at the same time raises the diaphragm which opens the main orifice.

Partial opening of the valve occurs at zero bar pressure, while a minimum Δp is required for total opening.

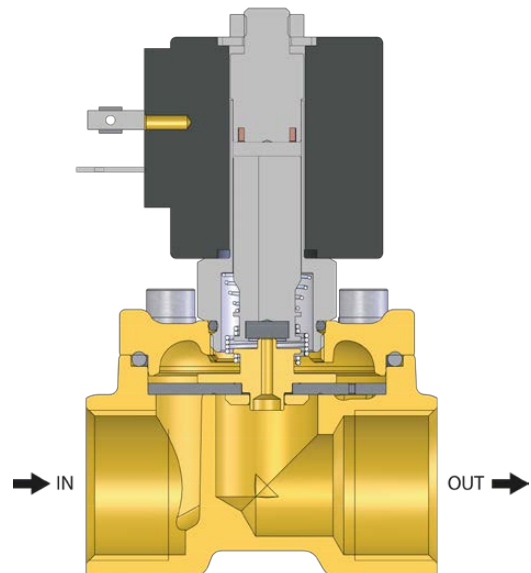

GENERAL TECHNICAL INFORMATION



Differential pressure Δp

Differential pressure (or pressure drop) means the pressures difference between the valve's inlet and outlet. The symbol is Δp .

Operating Pressure Difference (OPD)

Solenoid valves performances are measured with the maximum and minimum pressure difference between the valve inlet and outlet.

The maximum and minimum OPD are indicated notified for each valve model.

With MOPD (Maximum Operative Pressure Difference) indicates the maximum working Δp that the valve must overcome to allow the fluid to flow. With the same orifice, but with AC or DC voltage supply, the MOPD values can be different.

With mOPD (minimum Operative Pressure Difference) indicates the minimum working Δp to allow the opening or closing of the main orifice. In direct acting valves it can be 0 psi, while in servo-assisted valves it must always be > 0 psi.

Back pressure

Back pressure is the outlet pressure that works opposite to the desired flow. It is often generated due to kinks or bends in the pipes or spray nozzles placed downstream of the valve outlet, thus reducing the flow.

In 2-way solenoid valves the back pressure higher than the inlet pressure will not allow the valve to function correctly.

Whenever this situation occur, the recommendation is to use check valves to prevent the back pressure to run over the upstream circuit of the valve.

Maximum allowable pressure (PS)

The maximum allowable pressure (PS) is the maximum pressure that the valve can withstand before having damages to the internal components and/or having external leakages.

It's not related with the MOPD as long as it must be higher than or in any case equal to the inlet pressure.

FLOW COEFFICIENTS



Kv and Cv flow coefficients

Each solenoid valve has a Kv or Cv flow rate coefficient which varies according to the type and the orifice diameter.

The flow rate coefficient Kv, which use the metric system units of measurement, defines the flow of water that crosses the solenoid valve with a differential pressure of 1 bar at a temperature between 5°C and 40°C and is determined as indicated by VDE 2173 standards.

It is expressed in: m³/h or l/min.

The flow rate coefficient Cv uses the units of measurement of the Anglo-Saxon system and defines the flow of water that cross the solenoid valve at 60°F with a differential pressure of 1 psi.

It is expressed in US gpm (US gallons per minute).

The two values cannot be compared, but there are conversion formulas:

$$Kv = 0.857 * Cv$$

$$Cv = 1.165 * Kv$$

Knowing the type of fluid, the working pressure and the acceptable pressure drop, the Kv or Cv flow rate coefficient allows to calculate the flow rate that crosses the solenoid valve and the relative size for the proper use in the application.

VISCOSITY



The viscosity of a fluid is the physical magnitude that measures the resistance to flow opposed by a fluid. The viscosity heavily influences the valve's flow rate and MOPD.

The maximum recommended viscosity, expressed in cSt (centiStokes), is indicated for each valve diameter in the catalog tables.

The use of fluids with higher viscosity values could lead to reduced performances and occlusion of the valves' orifices.

Kinematics viscosity	Engler	Kinematics viscosity	Engler
centiStokes – cSt = mm ² /s	°E	centiStokes – cSt = mm ² /s	°E
1	1.00	30	4.08
3	1.22	37	4.97
4	1.31	40	5.35
5	1.40	50	6.65
7	1.57	53	7.04
10	1.83	60	7.92
12	2.02	70	9.24
15	2.30	80	10.56
20	2.88	90	11.88
25	3.44	100	13.20

FLOW CALCULATION

Symbols	Units of measure	Description
Kv	m ³ /h	Flow rate coefficient
Q	m ³ /h	Flow rate
Q_n	Nm ³ /h	Normal flow (20°C, 760mm Hg)
P₁	bar	Absolute inlet pressure (Pr + 1 bar)
P₂	bar	Absolute outlet pressure (Pr + 1 bar)
Δp	bar	Pressure drop (P1 - P2)
ρ	Kg/dm ³	Relative density to water (= 1)
ρ_n	Kg/dm ³	Normal density to air
G	Kg/h	Mass
T	°C	Inlet fluid temperature
V₁	m ³ /Kg	Specific inlet volume
V₂	m ³ /Kg	Specific outlet volume

Fluids	Formulas	
Liquids	$Q = Kv * \sqrt{\frac{\Delta p}{\rho}}$	
Gases	$\Delta p < \frac{P_1}{2} \rightarrow Q_n = 514 * Kv * \sqrt{\frac{\Delta p * P_2}{\rho_n * (273+T)}}$	$\Delta p > \frac{P_1}{2} \rightarrow Q_n = 257 * Kv * \sqrt{\frac{P_1}{\rho_n * (273+T)}}$
Air	$\Delta p < \frac{P_1}{2} \rightarrow Q_n = 26 * Kv * \sqrt{\Delta p * P_2}$	$\Delta p > \frac{P_1}{2} \rightarrow Q_n = Kv * P_1 * 13$
Steam	$\Delta p < \frac{P_1}{2} \rightarrow G = 31.6 * Kv * \sqrt{\frac{\Delta p}{V_2}}$	$\Delta p > \frac{P_1}{2} \rightarrow G = 31.6 * Kv * \sqrt{\frac{P_1}{V_1}}$

IP PROTECTION CLASS



The **CEI EN 60529/1997** (formerly CEI 70-1) standard classifies the protection degrees of enclosures for electrical equipments. The IP degree for the solenoid valves is indicated with two digits.

Solid bodies	
IP (1 st Digit)	Description
0	No protection
1	Protection from solid bodies > Ø 50 mm
2	Protection from solid bodies > Ø 12 mm
3	Protection from solid bodies > Ø 2.5 mm
4	Protection from solid bodies > Ø 1 mm
5	Protected against dusts (no harmful deposit)
6	Fully protected against dusts

Liquid bodies	
IP (2 nd Digit)	Description
0	No protection
1	Protection against vertical falls of water drops
2	Protection against falling drops of water or rain up to 15° from the vertical
3	Protection against falling drops of water or rain up to 60° from the vertical
4	Protection against water splashes from all directions
5	Protection against water jets
6	Protection against powerful jets of water
7	Protection against the effects of temporary diving
8	Protection against the effects of continuous diving

COILS TECHNICAL INFORMATION



Coils power

The power, or electrical absorption, indicated for each coil is it's registred at the ambient temperature of 68°F and at the nominal voltage, and is expressed in:

- Watt (W), for Direct Current (DC) power supplies;

in the DC-powered coils, the active power remains constant both during the inrush phase and when the mobile plunger stroke cycle is completed.

- VoltAmpere (VA), for Alternating Current (AC) power supplies; in the AC-powered coils only the apparent power it's indicated in the holding state (when the mobile plunger has completed its stroke cycle); it must be considered that the apparent power during the inrush phase (at the electrical insertion) is always higher than the holding state.

$$P (W \text{ or } VA) = V (\text{Volt}) \times I (\text{Ampere}) = \frac{V^2 (\text{Volt})}{R (\text{Ohm } \Omega)}$$

The power can be expressed in Watts even in the case of AC power supplies; in this case there is a displacement between voltage and current indicated as power factor or $\cos \phi$ (Phi). This value can vary between 0 and 1.

$$P (W) = V (\text{Volt}) \times I (\text{Ampere}) \times \cos \phi$$



Continuous Service (ED)

The "Continuous Service (ED)" is intended as the maximum electrical insertion time tolerated by the coil compared to the thermal time constant of the coil.

Coils in Continuous Service are identified with ED100%, while for non-continuous service coils (e.g.: ED50%) it is necessary to intersperse electrical insertion times and rest times.

The ED is calculated with the following formula:

$$ED = \frac{\text{insertion time}}{\text{insertion time} + \text{rest time}} \times 100$$

Example:

$$ED = \frac{10'}{10' + 10'} \times 100 = ED 50\%$$

For non-continuous services it is possible to use coils with higher powers than the standard ones or to use coils with ambient temperatures higher than the indicated ones.



Coils insulation class

The insulation class identifies the maximum winding temperature that each coil can withstand to ensure normal operation.

When the winding is crossed by the current it heats up due to the Joule effect; the heating varies according to the time during which the coil is powered.

Aignep uses standard class H coils, which can work at a winding temperature of +356°F.



Ambient temperature

The minimum and maximum ambient temperature determines the safety limits dictated by the insulation class of the coil. It depends on the materials of the winding and encapsulation of the coil and is defined by the sector's directives.

TEMPERATURE VALUES CONVERSION TABLE

°F	°C	K	°F	°C	K	°F	°C	K
-40	-40	233.15	104	40	313.15	284	140	413.15
-31	-35	238.15	113	45	318.15	302	150	423.15
-22	-30	243.15	122	50	323.15	320	160	433.15
-13	-25	248.15	131	55	328.15	338	170	443.15
-4.0	-20	253.15	140	60	333.15	356	180	453.15
5.0	-15	258.15	149	65	338.15	374	190	463.15
14	-10	263.15	158	70	343.15	392	200	473.15
23	-5	268.15	167	75	348.15	428	220	493.15
32	0	273.15	176	80	353.15	464	240	513.15
41	5	278.15	185	85	358.15	500	260	533.15
50	10	283.15	194	90	363.15	536	280	553.15
59	15	288.15	203	95	368.15	572	300	573.15
68	20	293.15	212	100	373.15	662	350	623.15
77	25	298.15	230	110	383.15	752	400	673.15
86	30	303.15	248	120	393.15	842	450	723.15
95	35	308.15	266	130	403.15	932	500	773.15

PRESSURE VALUE CONVERSION TABLE

Psi	Bar	MPa	mH ₂ O	Psi	Bar	Mpa	mH ₂ O
1.45	0.1	0.01	1.02	203.00	14	1.40	142.80
2.90	0.2	0.02	2.04	217.50	15	1.50	153.00
4.35	0.3	0.03	3.06	232.00	16	1.60	163.20
5.80	0.4	0.04	4.08	246.50	17	1.70	173.40
7.25	0.5	0.05	5.10	261.00	18	1.80	183.60
8.70	0.6	0.06	6.12	275.50	19	1.90	193.80
10.15	0.7	0.07	7.14	290.00	20	2.00	204.00
11.60	0.8	0.08	8.16	304.50	21	2.10	214.20
13.05	0.9	0.09	9.18	319.00	22	2.20	224.40
14.50	1	0.10	10.20	333.50	23	2.30	234.60
21.75	1.5	0.15	15.30	348.00	24	2.40	244.80
29.00	2	0.20	20.40	362.50	25	2.50	255.00
36.25	2.5	0.25	25.50	377.00	26	2.60	265.20
43.50	3	0.30	30.60	391.50	27	2.70	275.40
50.75	3.5	0.35	35.70	406.00	28	2.80	285.60
58.00	4	0.40	40.80	420.50	29	2.90	295.80
65.25	4.5	0.45	45.90	435.00	30	3.00	306.00
72.50	5	0.50	51.00	507.50	35	3.50	357.00
79.75	5.5	0.55	56.00	580.00	40	4.00	408.00
87.00	6	0.60	61.20	652.50	45	4.50	459.00
94.25	6.5	0.65	66.30	725.00	50	5.00	510.00
101.50	7	0.70	71.40	797.50	55	5.50	561.00
108.75	7.5	0.75	76.50	870.00	60	6.00	612.00
116.00	8	0.80	81.60	942.50	65	6.50	663.00
123.25	8.5	0.85	86.70	1015.00	70	7.00	714.00
130.50	9	0.90	91.80	1087.50	75	7.50	765.00
137.75	9.5	0.95	96.90	1160.00	80	8.00	816.00
145.00	10	1.00	102.00	1232.50	85	8.50	867.00
159.50	11	1.10	112.20	1305.00	90	9.00	918.00
174.00	12	1.20	122.40	1377.50	95	9.50	969.00
188.50	13	1.30	132.60	1450.00	100	10.00	1020.00

STEAM: PRESSURE - TEMPERATURE CONVERSION TABLE

Relative pressure	Absolute pressure	Temperature		Specific volume
		°F	°C	
psi (g)	psi (a)			m ³ /Kg
0	14.69	212.0	100.0	1.673
1.45	16.14	216.7	102.6	1.533
2.90	17.59	223.2	106.2	1.414
4.35	19.04	225.3	107.4	1.312
7.25	21.94	232.9	111.6	1.149
10.15	24.84	239.7	115.4	1.024
14.50	29.19	248.7	120.4	0.881
21.75	36.44	261.7	127.6	0.714
29.00	43.69	272.7	133.7	0.603
36.25	50.94	282.2	139.0	0.522
43.50	58.19	290.7	143.7	0.461
50.75	65.44	298.4	148.0	0.413
58.00	72.69	305.6	152.0	0.374
65.25	79.94	311.9	155.5	0.342
72.50	87.19	318.0	158.9	0.315
87.00	101.69	329.0	165.0	0.272
101.50	116.19	338.9	170.5	0.240
116.00	130.69	347.7	175.4	0.215
130.50	145.19	356.0	180.0	0.194
145.00	159.69	363.4	184.1	0.177

Response times

The response time of the opening (or closing) of a solenoid valve is defined as the time interval between the electrical insertion (or disconnection) and the moment in which the outlet (or inlet) pressure reaches 50% of the maximum value.

Valves type	Response times		Note
	Open	Close	
Direct acting NC 2/2 - 3/2	~ 10 ms	~ 20 ms	Response times may vary according to the fluid (gas or liquid), pressure, flow rate, viscosity and voltage supply (AC or DC).
Direct acting NO 2/2 - 3/2	~ 20 ms	~ 10 ms	
Servo-assisted NC 1/4" → 2"	50 ms → 500 ms	70 ms → 600 ms	
Servo-assisted NO 1/4" → 2"	70 ms → 600 ms	50 ms → 500 ms	



FLUIDS	BODY MATERIAL		SEALS		
	Brass	Stainless Steel AISI 316L	NBR	EPDM	FKM
Acetone	●	●	●	●	●
Acetylene	●	●	●	●	●
Argon	●	●	●	●	●
Benzene	●	●	●	●	●
Butane	●	●	●	●	●
Carbon dioxide dry (gas)	●	●	●	●	●
Carbon dioxide dry (liquid)	●	●	●	●	●
Carbon disulfide	●	●	●	●	●
Chloroform (100%)	●	●	●	●	●
Diesel fuel	●	●	●	●	●
Helium	●	●	●	●	●
Ethane	●	●	●	●	●
Ethanol	●	●	●	●	●
Ethyl acetate	●	●	●	●	●
Ethyl chloride	●	●	●	●	●
Ethylene glycol	●	●	●	●	●
Formaldehyde (100%)	●	●	●	●	●
Freon	●	●	●	●	●
Glycerine	●	●	●	●	●
Heptane	●	●	●	●	●
Hexane	●	●	●	●	●
Hydrogen	●	●	●	●	●
Hydrogen peroxide	●	●	●	●	●
Isobutane	●	●	●	●	●
Isopentane	●	●	●	●	●
Methane	●	●	●	●	●
Methanol	●	●	●	●	●
Methyl chloride	●	●	●	●	●
Mineral oil	●	●	●	●	●
Neon	●	●	●	●	●
Nitrobenzene	●	●	●	●	●
Nitrogen	●	●	●	●	●
Oxygen	●	●	●	●	●
Pentane	●	●	●	●	●
Petrol	●	●	●	●	●
Propane (LPG)	●	●	●	●	●
Propyl Alcohol	●	●	●	●	●
Toluene	●	●	●	●	●
Trichlorethylene dry	●	●	●	●	●
Vinegar	●	●	●	●	●
Water demineralized	●	●	●	●	●
Water (Hard)	●	●	●	●	●
Water (Hot <75°C)	●	●	●	●	●
Water (Hot-steam <140°C)	●	●	●	●	●
Water with glycol	●	●	●	●	●
Xylene	●	●	●	●	●

LEGEND:

- COMPATIBLE
- INCOMPATIBLE
- ASK TO TECHNICAL DEPARTMENT

SEALING MATERIALS FEATURES

Sealing materials	Temperature		Fluids
	min	max	
NBR	+14°F	+194°F	Air, inert gases, water, mineral oils, diesel, fuel oils
NBR 	-40°F	+194°F	Air, inert gases, water, mineral oils, diesel, fuel oils
FKM	+14°F	+284°F	Mineral oils, gasoline, diesel, fuel oils
EPDM	+14°F	+284°F	Hot water, steam (max pressure 36 psi)
PTFE	-40°F	+356°F	Steam (max pressure 145 psi), solvents, aggressive fluids
RUBY	-40°F	+356°F	Water, hot water, demineralized water, steam (max pressure 145 psi), aggressive fluids
CR	-31°F	+212°F	Refrigerants, water-glycol mixtures, ozone

INSTALLATION AND MAINTENANCE

INSTALLATION'S WARNINGS

- Before to proceed with the installation, make sure that the valve model is suitable for the use in the application, verifying that fluid, temperatures, pressures and operating flow rates doesn't exceed the values indicated in the technical tables shown in the Aignep catalog and also on the website www.aignep.com.
- Make sure that the valve is correctly sized for the piping used and that the flow is flowing in the direction indicated by the arrow on the valve body.
- Make sure that there aren't foreign bodies or impurities in the fluid that could obstruct the passage and compromise the functionality of the valves; Aignep always recommends a filter installation upstream.
- For corrosive fluids and environments make sure that all the materials are compatible (contact Aignep in case of doubt or further information).
- It is recommended to install the valve in a horizontal position with the operator facing upwards to prevent possible impurities from depositing in the armature tube of the solenoid valve.
- During the installation on the pipes:
 - Make sure that the pipes are pressureless;
 - Assemble the valve with the pipes and/or fittings whose threads are compatible with the connection;
 - Avoid any kind of torsion or forcing on the valve;
 - Do not use the armature tube as a socket for screwing the valve;
 - Make sure that the connections to the piping are free of leaks (use appropriate PTFE sealants or tapes; pay attention to liquid sealants that can clog the valve operating orifices);
 - Make sure that the valve is not subjected to stresses and vibrations.
- It is recommended to install the valve in easy positions, to allow simple maintenance or replacement of the coil.
- Avoid the valve being immersed in liquids or exposed to jets of water or steam.
- The use of servo-assisted valves with free exhaust is not recommended, unless suitably sized.
- In case of condensation, use the anti-humidity kit (see Aignep catalog).
- WARNING:** to guarantee the indicated performances it is recommended to use Aignep's valves and coils.

ELECTRICAL CONNECTIONS

- The coil, when installed on the operator, can be rotated on its axis to place it in the desired position. Once the most suitable position is identified, anchor the coil by fixing the nut to the operator, with a maximum torque of 3.685 ft-lbs.
- Connect the coils correctly with the appropriate connectors, paying attention to the grounding.
- Aignep coils are suitable for continuous service ED 100%.

TEMPERATURES

- Although the coils conform to high temperatures, it is always recommended to install the valves away from heat sources to avoid excessive overheating.
- Always check the operating temperatures in the catalog and if in doubt consult Aignep.
- The temperatures of use must take into account the environment and also the temperatures of the fluids.
- WARNING:** when energized the coils tend to overheat. Do not touch them with your hands.
- WARNING:** in case of installation with ambient temperature < +32°F, the freezing of the fluid may cause serious damage to the solenoid valve.

MAINTENANCE

- Before carrying out any type of maintenance or disassembly, in order to avoid possible damage to people or surrounding objects, make sure that the pressure in the circuit has been released.
- Make sure the coil is de-energized.
- Remove the nut using the correct size hex wrench and slide off the coil.
- Remove the operator kit with the appropriate hex wrench; it is advisable not to use tools that could damage the operator kit.
- In the diaphragm version remove also the cover by unscrewing the n. 4 screws.
- Inspect the valve by cleaning the individual components from possible foreign bodies and replace the parts worn or corroded by the use; it is recommended to use original Aignep spare parts only.
- Make sure all the components are correctly installed and then close the valve.
- To fix the operator kit on the valve body and the coil fixing nut, use respectively a maximum tightening torque of 7.37 ft-lbs and 3.685 ft-lbs.

2/2 NC

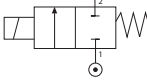



□ 25 x 25 mm

Page 3.3

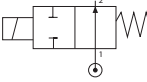

2/2 NO





□ 25 x 25 mm

Page 3.5

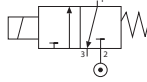

3/2 NC





□ 25 x 25 mm

Page 3.7

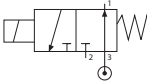

3/2 NO





□ 25 x 25 mm

Page 3.9

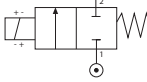

2/2 LATCHING

□ 25 x 25 mm

Page 3.11



22 mm



Series A

Page 15.2



30 mm



Series B

Page 15.3



Connectors

Page 15.8 - 15.10



**DIRECT ACTING SOLENOID VALVES WITH FLANGE
FIXING AND BRASS CW510L BODY - PB ≤ 0.1%**

CW510L / Pb ≤ 0.1%

Ex
II 2 G/D Ex h

UL US
CSA C22.2

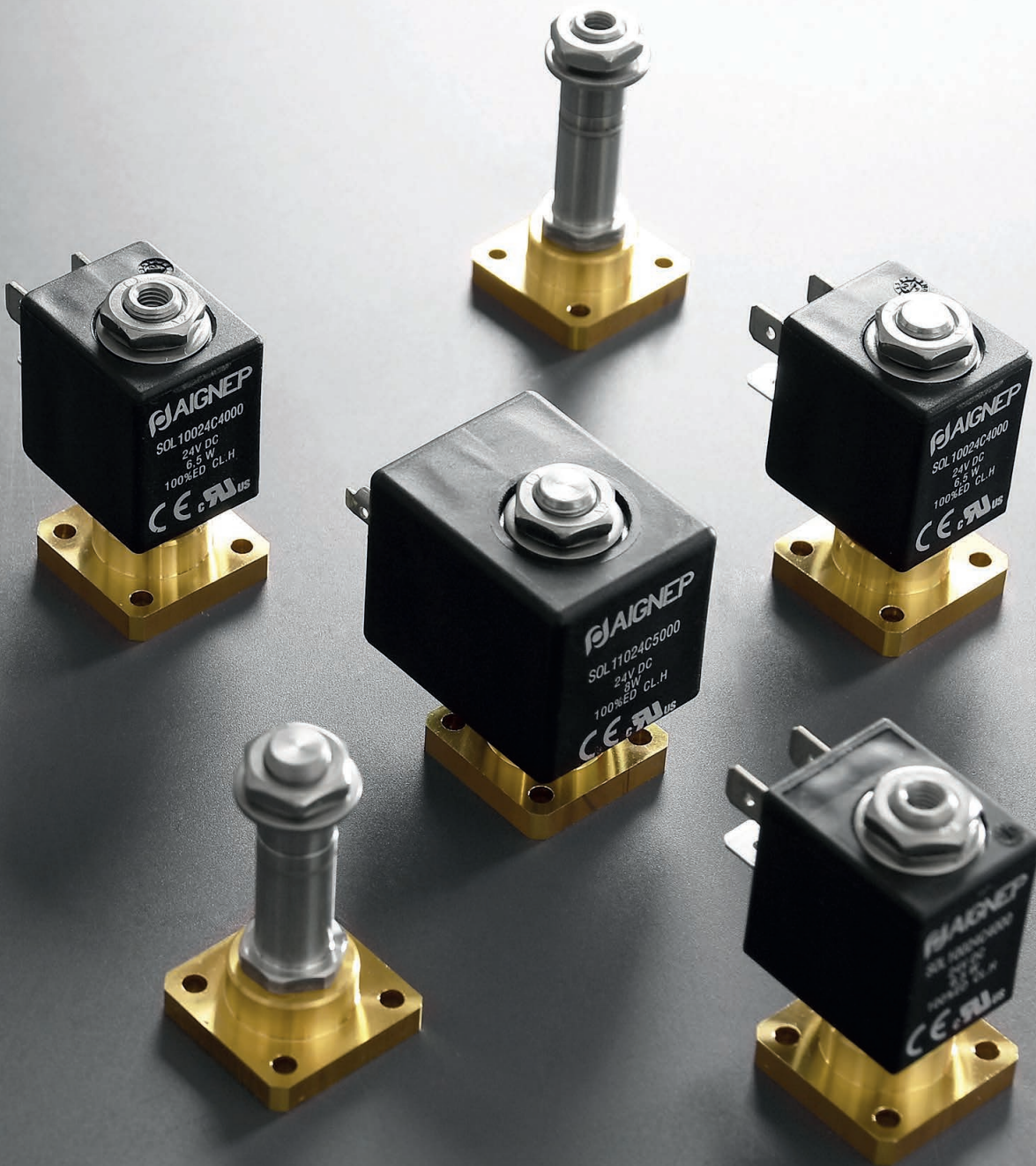

Series F1F

Series F1F

DIRECT ACTING SOLENOID VALVES WITH FLANGE FIXING AND BRASS CW510L BODY

2/2 NC

25 x 25 mm

CW510L
Pb ≤ 0.1%

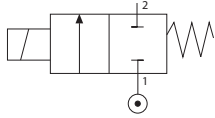

Component Parts and Materials

- 1 Body: Brass CW510L - Pb ≤ 0.1%
- 2 Seals: NBR - EPDM - FKM - CR - NBR ❄️
- 3 Armature tube: Stainless steel
- 4 Fixed and mobile core: Stainless steel AISI 430FR
- 5 Springs: Stainless steel



General features - F1F

- Universal mounting position
- Operator kit Ø 10 mm
- ATEX II 2G/D Ex h certification
- Coils: Class H - - CSA C22.2



Maximum allowable pressure

580 psi (40 bar)



Compatibility and materials table

Page 0.13 - 0.14



Room temperature with coil class H

+14°F +176°F
-10°C +80°C



Applications

- Food industry
- Coffee & vending
- Compressors
- Water and Neutral liquids
- Air and Inert gases
- Oils, Steam, Vacuum



Ordering codes

Series	Port size	Functions	Orifice inch (mm)	Sealing materials	Version	Suitable coils
F 1 F	J 4 J4 = □ 25x25 mm	1 1 = 2/2 NC	1 5 15 = 1/16 (1.5) 02 = 5/64 (2) 25 = 3/32 (2.5)	N N = NBR E = EPDM V = FKM C = CR F = NBR ❄️	0 0 = Standard	A A A = A series - SOL10 A = 12V DC B = B series - SOL11 B = 24V DC 1 = 24V AC 2 = 110V AC 3 = 220V AC

Valves and coils are supplied separately. Upon commercial agreements can be supplied assembled.

Code	Sealing materials	Port size	Ø Orifice	Viscosity	Cv (Kv)	Differential pressure (OPD)			Power		Coils				
						inch (mm)	cSt	gpm (m³/h)	psi (bar)			DC	AC	Size	Series
									Min	Max DC	Max AC	W	VA	mm	A - Page 15.2 B - Page 15.3
F1F J4 1 15 _0	N = NBR +14°F +194°F (-10°C +90°C) V = FKM +14°F +284°F (-10°C +140°C)	□ 25x25 mm	1/16 (1.5)	25	0.07 (0.06)	0	232 (16)	435 (30)	6.5	7.5	22	A - SOL10			
F1F J4 1 02 _0	E = EPDM +14°F +284°F (-10°C +140°C) C = CR -31°F +212°F (-35°C +100°C)		5/64 (2)	37	0.10 (0.09)		0	174 (12)	363 (25)	6.5	7.5	22	A - SOL10		
F1F J4 1 25 _0	F = NBR ❄️ -40°F +194°F (-40°C +90°C)		3/32 (2.5)	53	0.17 (0.15)	0		65 (4.5)	261 (18)	6.5	7.5	22	A - SOL10		
								580 (40)	580 (40)	8	11	30	B - SOL11		
							435 (30)	580 (40)	8	11	30	B - SOL11			
							189 (13)	435 (30)	8	11	30	B - SOL11			

① Select seal material

With steam: EPDM - P max = 36 psi (2.5 bar)

Coil not included

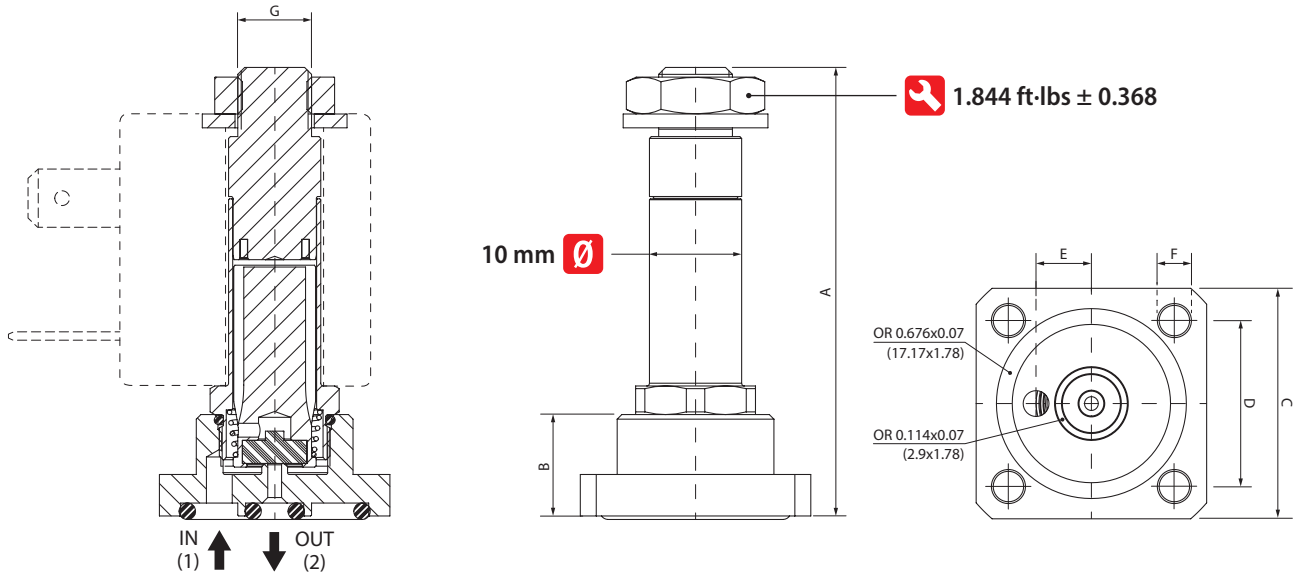

Size	A	B	C	D	E	F	G
	inch (mm)	inch (mm)	inch (mm)	inch (mm)	inch (mm)	inch (mm)	
□ 25x25 mm	1.915 (48.65)	0.433 (11)	0.984 (25)	0.708 (18)	0.236 (6)	0.129 (3.3)	M8 x 0.75

Series F1F

DIRECT ACTING SOLENOID VALVES WITH FLANGE FIXING AND BRASS CW510L BODY

2/2 NO

25 x 25 mm

CW510L
Pb ≤ 0.1%

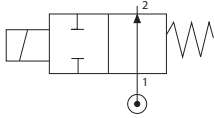

Component Parts and Materials

- 1 Body: Brass CW510L - Pb ≤ 0.1%
- 2 Seals: NBR - EPDM - FKM - CR
- 3 Armature tube: Stainless steel
- 4 Fixed and mobile core: Stainless steel AISI 430FR
- 5 Springs: Stainless steel



General features - F1F

- Universal mounting position
- Operator kit Ø 10 mm
- ATEX II 2G/D Ex h certification
- Coils: Class H - - CSA C22.2



Maximum allowable pressure

580 psi (40 bar)



Compatibility and materials table

Page 0.13 - 0.14



Room temperature with coil class H

+14°F +176°F
-10°C +80°C



Applications

- Food industry
- Coffee & vending
- Compressors
- Water and Neutral liquids
- Air and Inert gases
- Oils, Steam, Vacuum



Ordering codes

Series	Port size	Functions	Orifice inch (mm)	Sealing materials	Version	Suitable coils
F 1 F	J 4 J4 = □ 25x25 mm	2 2 = 2/2 NO	1 5 15 = 1/16 (1.5) 02 = 5/64 (2) 25 = 3/32 (2.5)	N N = NBR E = EPDM V = FKM C = CR	0 0 = Standard	A A A = A series - SOL10 A = 12V DC B = B series - SOL11 B = 24V DC 1 = 24V AC 2 = 110V AC 3 = 220V AC

Valves and coils are supplied separately. Upon commercial agreements can be supplied assembled.

Code	Sealing materials	Port size	Ø Orifice	Viscosity	Cv (Kv)	Differential pressure (OPD)			Power		Coils				
						inch (mm)	cSt	gpm (m³/h)	psi (bar)			DC	AC	Size	Series
									Min	Max DC	Max AC	W	VA	mm	A - Page 15.2 B - Page 15.3
F1F J4 2 15 _0	N = NBR +14°F +194°F (-10°C +90°C)	□ 25x25 mm	1/16 (1.5)	25	0.07 (0.06)	0	-	261 (18)	-	7.5	22	A - SOL10			
F1F J4 2 02 _0	V = FKM +14°F +284°F (-10°C +140°C)		5/64 (2)	37	0.10 (0.09)	0	-	145 (10)	8	11	30	B - SOL11			
F1F J4 2 25 _0	E = EPDM +14°F +284°F (-10°C +140°C)		3/32 (2.5)	53	0.17 (0.15)	0	-	94 (6.5)	-	7.5	22	A - SOL10			
	C = CR -31°F +212°F (-35°C +100°C)						94 (6.5)	94 (6.5)	8	11	30	B - SOL11			

① Select seal material

With steam: EPDM - P max = 36 psi (2.5 bar)

Coil not included

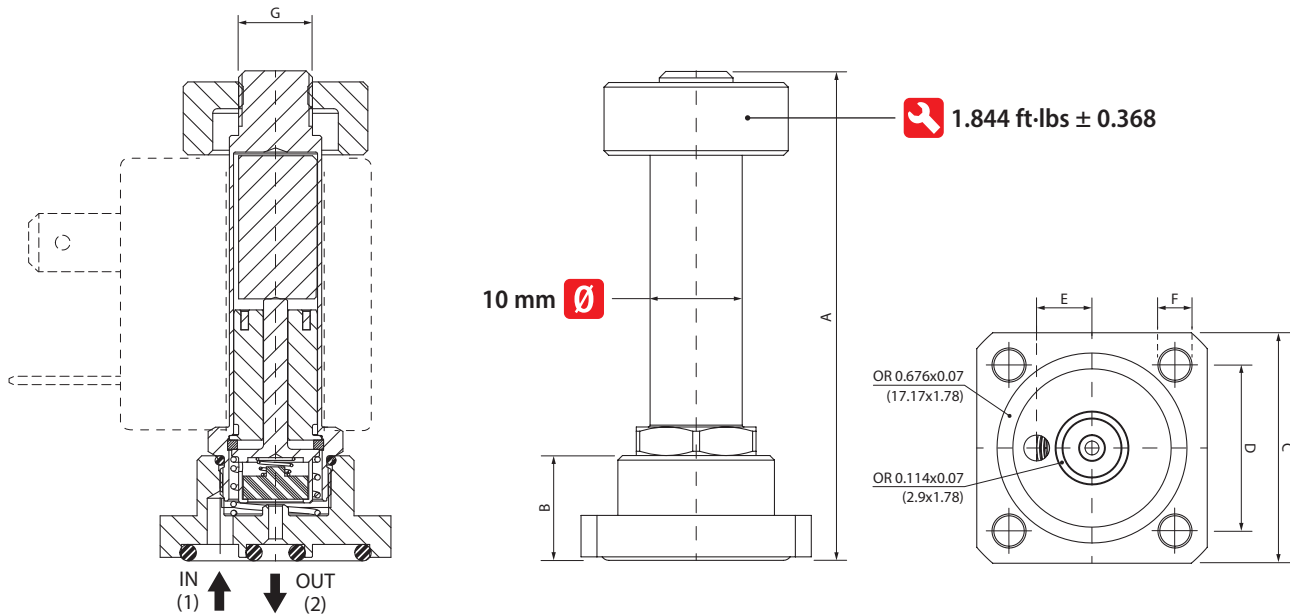

Size	A	B	C	D	E	F	G
	inch (mm)	inch (mm)	inch (mm)	inch (mm)	inch (mm)	inch (mm)	
□ 25x25 mm	2.271 (57.7)	0.433 (11)	0.984 (25)	0.708 (18)	0.236 (6)	0.129 (3.3)	M8 x 1

Series F1F

DIRECT ACTING SOLENOID VALVES WITH FLANGE FIXING AND BRASS CW510L BODY

3/2 NC

25 x 25 mm

CW510L
Pb ≤ 0.1%

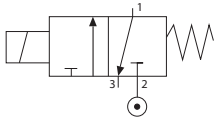

Component Parts and Materials

- 1 Body: Brass CW510L - Pb ≤ 0.1%
- 2 Seals: NBR - EPDM - FKM
- 3 Armature tube: Stainless steel
- 4 Fixed and mobile core: Stainless steel AISI 430FR
- 5 Springs: Stainless steel



General features - F1F

- Universal mounting position
- Operator kit Ø 10 mm
- ATEX II 2G/D Ex h certification
- Coils: Class H - - CSA C22.2



Maximum allowable pressure

580 psi (40 bar)



Compatibility and materials table

Page 0.13 - 0.14



Room temperature with coil class H

+14°F +176°F
-10°C +80°C



Applications

- Food industry
- Coffee & vending
- Compressors
- Water and Neutral liquids
- Air and Inert gases
- Oils, Steam, Vacuum



Ordering codes

Series	Port size	Functions	Orifice inch (mm)	Sealing materials	Version	Suitable coils
F 1 F	J 4 J4 = □ 25x25 mm	3 3 = 3/2 NC	1 5 15 = 1/16 (1.5) 02 = 5/64 (2) 25 = 3/32 (2.5)	N N = NBR E = EPDM V = FKM	0 0 = Standard	A A A = A series - SOL10 A = 12V DC B = B series - SOL11 B = 24V DC 1 = 24V AC 2 = 110V AC 3 = 220V AC

Valves and coils are supplied separately. Upon commercial agreements can be supplied assembled.

Code	Sealing materials	Port size	Ø Orifice		Viscosity	Cv (Kv)		Differential pressure (OPD)			Power		Coils		
			inch (mm)			cSt	gpm (m ³ /h)		psi (bar)			DC	AC	Size	Series
			IN	EXH			IN	EXH	Min	Max DC	Max AC	W	VA	mm	A - Page 15.2 B - Page 15.3
F1F J4 3 15 _0	N = NBR +14°F +194°F (-10°C +90°C)	□ 25x25 mm	1/16 (1.5)	1/16 (1.4)	25	0.07 (0.06)	0.06 (0.05)	0	145 (10)	145 (10)	6.5	7.5	22	A - SOL10	
F1F J4 3 02 _0	V = FKM +14°F +284°F (-10°C +140°C)		5/64 (2)	1/16 (1.4)	25	0.10 (0.09)	0.06 (0.05)	0	87 (6)	87 (6)	8	11	30	B - SOL11	
F1F J4 3 25 _0	E = EPDM +14°F +284°F (-10°C +140°C)		3/32 (2.5)	1/16 (1.4)	25	0.17 (0.15)	0.06 (0.05)	0	58 (4)	58 (4)	6.5	7.5	22	A - SOL10	
									58 (4)	58 (4)	8	11	30	B - SOL11	

① Select seal material

With steam: EPDM - P max = 36 psi (2.5 bar)

Coil not included

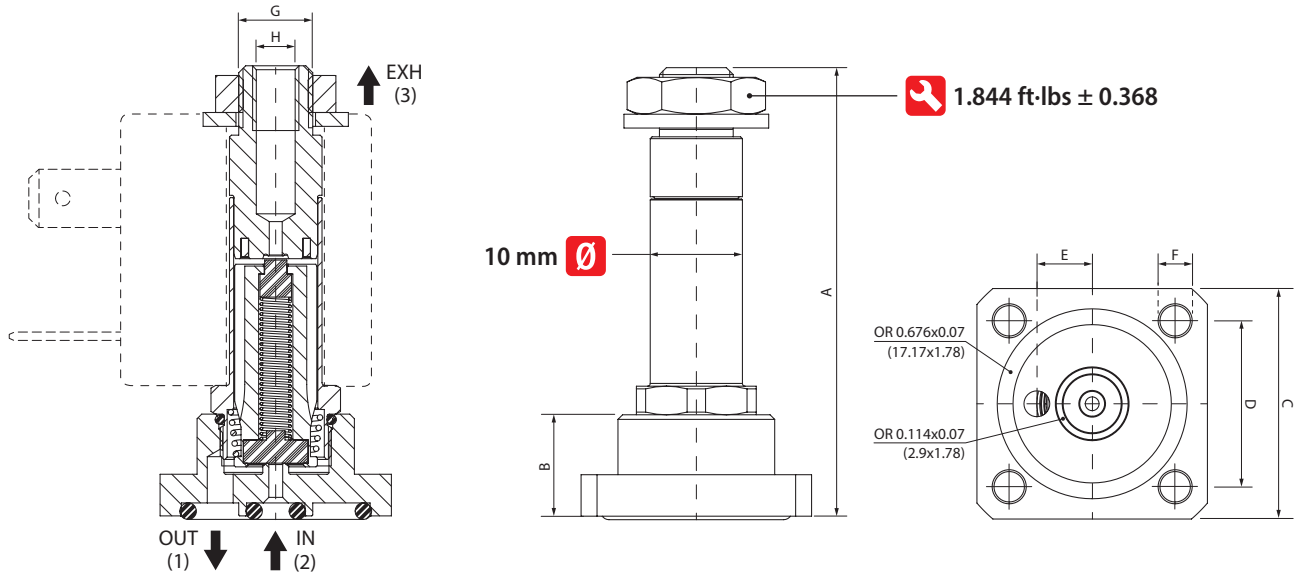

Size	A	B	C	D	E	F	H	G
	inch (mm)	inch (mm)	inch (mm)	inch (mm)	inch (mm)	inch (mm)		
□ 25x25 mm	1.915 (48.65)	0.433 (11)	0.984 (25)	0.708 (18)	0.236 (6)	0.129 (3.3)	M5	M8 x 0.75

Series F1F

DIRECT ACTING SOLENOID VALVES WITH FLANGE FIXING AND BRASS CW510L BODY

3/2 NO

25 x 25 mm

CW510L
Pb ≤ 0.1%

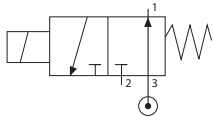

Component Parts and Materials

- 1 Body: Brass CW510L - Pb ≤ 0.1%
- 2 Seals: NBR - EPDM - FKM
- 3 Armature tube: Stainless steel
- 4 Fixed and mobile core: Stainless steel AISI 430FR
- 5 Springs: Stainless steel



General features - F1F

- Universal mounting position
- Operator kit Ø 10 mm
- ATEX II 2G/D Ex h certification
- Coils: Class H - - CSA C22.2



Maximum allowable pressure

580 psi (40 bar)



Compatibility and materials table

Page 0.13 - 0.14



Room temperature with coil class H

+14°F +176°F
-10°C +80°C



Applications

- Food industry
- Coffee & vending
- Compressors
- Water and Neutral liquids
- Air and Inert gases
- Oils, Steam, Vacuum



Ordering codes

Series	Port size	Functions	Orifice inch (mm)	Sealing materials	Version	Suitable coils
F 1 F	J 4 J4 = □ 25x25 mm	4 4 = 3/2 NO	1 5 15 = 1/16 (1.5) 02 = 5/64 (2) 25 = 3/32 (2.5)	N N = NBR E = EPDM V = FKM	0 0 = Standard	A A A = A series - SOL10 A = 12V DC B = B series - SOL11 B = 24V DC 1 = 24V AC 2 = 110V AC 3 = 220V AC

Valves and coils are supplied separately. Upon commercial agreements can be supplied assembled.

Code	Sealing materials	Port size	Ø Orifice		Viscosity	Cv (Kv)		Differential pressure (OPD)			Power		Coils		
			inch (mm)			cSt	gpm (m ³ /h)		psi (bar)			DC	AC	Size	Series
			IN	EXH			IN	EXH	Min	Max DC	Max AC	W	VA	mm	A - Page 15.2 B - Page 15.3
F1F J4 4 15 _0	N = NBR +14°F +194°F (-10°C +90°C)	□ 25x25 mm	1/16 (1.4)	1/16 (1.5)	25	0.06 (0.05)	0.07 (0.06)	0	145 (10)	145 (10)	6.5	7.5	22	A - SOL10	
F1F J4 4 02 _0	V = FKM +14°F +284°F (-10°C +140°C)		1/16 (1.4)	5/64 (2)	25	0.06 (0.05)	0.10 (0.09)	0	145 (10)	145 (10)	8	11	30	B - SOL11	
F1F J4 4 25 _0	E = EPDM +14°F +284°F (-10°C +140°C)		1/16 (1.4)	3/32 (2.5)	25	0.06 (0.05)	0.17 (0.15)	0	58 (4)	145 (10)	6.5	7.5	22	A - SOL10	
									145 (10)	145 (10)	8	11	30	B - SOL11	

① Select seal material

With steam: EPDM - P max = 36 psi (2.5 bar)

Coil not included

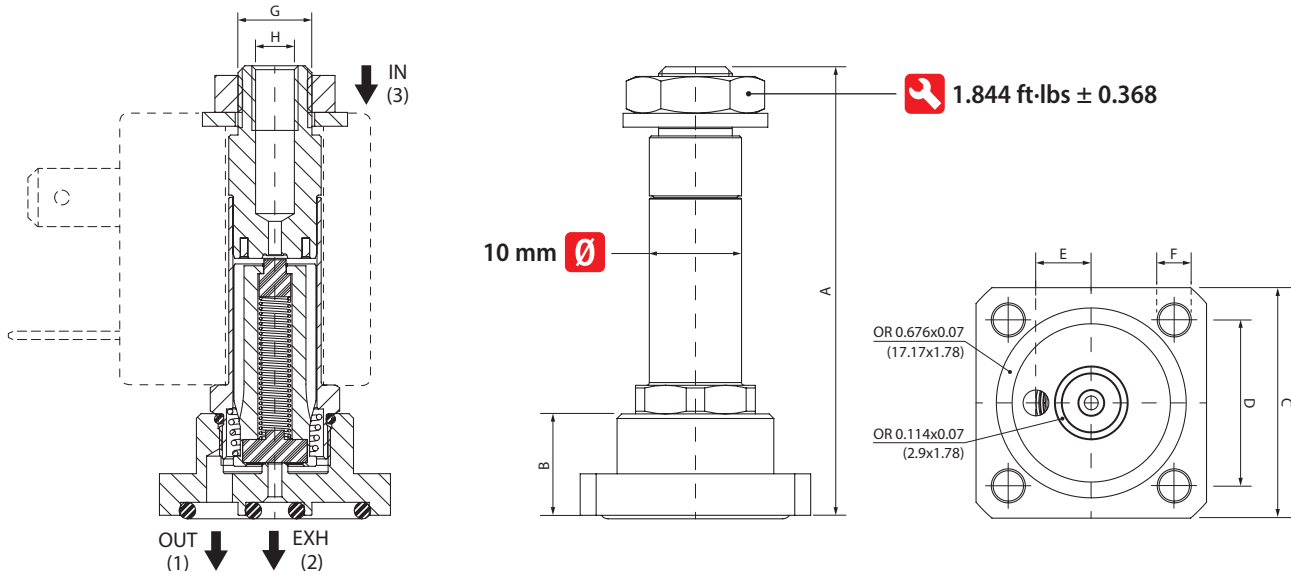

Size	A	B	C	D	E	F	H	G
	inch (mm)	inch (mm)	inch (mm)	inch (mm)	inch (mm)	inch (mm)		
□ 25x25 mm	1.915 (48.65)	0.433 (11)	0.984 (25)	0.708 (18)	0.236 (6)	0.129 (3.3)	M5	M8 x 0.75

Series F1F

DIRECT ACTING SOLENOID VALVES WITH FLANGE FIXING AND BRASS CW510L BODY

2/2 LATCHING

25 x 25 mm

CW510L
Pb ≤ 0.1%

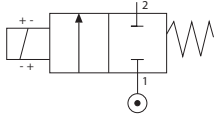

Pulse switching ≥20 ms, polarity reversed

Ordering codes



Series	Port size	Functions	Orifice inch (mm)	Sealing materials	Version	Suitable coils
F 1 F	J 4 J4 = □ 25x25 mm	B B = 2/2 Latching	1 5 15 = 1/16 (1.5) 02 = 5/64 (2) 25 = 3/32 (2.5)	N N = NBR E = EPDM V = FKM C = CR	0 0 = Standard	A A A = A series - SOL10 B = B series - SOL11 F = 3V DC H = 9V DC A = 12V DC B = 24V DC

Valves and coils are supplied separately. Upon commercial agreements can be supplied assembled.



Component Parts and Materials

- 1 Body: Brass CW510L - Pb ≤ 0.1%
- 2 Seals: NBR - EPDM - FKM - CR
- 3 Armature tube: Stainless steel
- 4 Fixed and mobile core: Stainless steel AISI 430FR
- 5 Springs: Stainless steel



General features - F1F

- Universal mounting position
- Operator kit Ø 10 mm
- ATEX II 2G/D Ex h certification
- Coils: Class H - - CSA C22.2



Maximum allowable pressure

580 psi (40 bar)



Compatibility and materials table

Page 0.13 - 0.14



Room temperature with coil class H

+14°F +176°F
-10°C +80°C



Applications

- Food industry
- Coffee & vending
- Compressors
- Water and Neutral liquids
- Air and Inert gases
- Oils, Steam, Vacuum

Code	Sealing materials	Port size	Ø Orifice	Viscosity	Cv (Kv)	Differential pressure (OPD)		Power	Coils					
						inch (mm)	cSt		gpm (m³/h)	psi (bar)		DC	Size	Series
										Min	Max DC			
F1F J4 B 15 _0	N = NBR +14°F +194°F (-10°C +90°C)	 25x25 mm	1/16 (1.5)	25	0.07 (0.06)	0	145 (10)	2	22	A - SOL10				
							290 (20)				3	22	A - SOL10	
							507 (35)							4
F1F J4 B 02 _0	V = FKM +14°F +284°F (-10°C +140°C)	 25x25 mm	5/64 (2)	25	0.10 (0.09)	0	94 (6.5)	2	22	A - SOL10				
							188 (13)				3	22	A - SOL10	
							333 (23)							4
F1F J4 B 25 _0	C = CR -31°F +212°F (-35°C +100°C)	 25x25 mm	3/32 (2.5)	25	0.17 (0.15)	0	36 (2.5)	2	22	A - SOL10				
							72 (5)				3	22	A - SOL10	
							145 (10)							4

① Select seal material

With steam: EPDM - P max = 36 psi (2.5 bar)

Coil not included

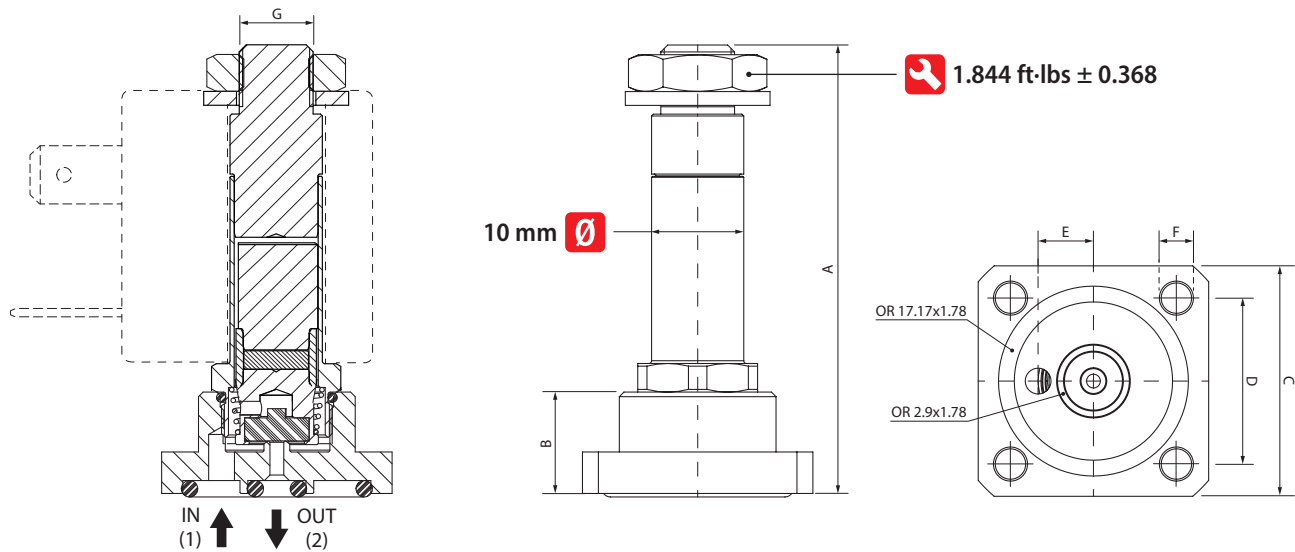

Size	A	B	C	D	E	F	G
	inch (mm)	inch (mm)	inch (mm)	inch (mm)	inch (mm)	inch (mm)	
25x25 mm	1.915 (48.65)	0.433 (11)	0.984 (25)	0.708 (18)	0.236 (6)	0.129 (3.3)	M8 x 0.75