

SERIE 740 EUROPEAN PROFILE

GIUNTI AD INNESTO RAPIDO A DOPPIA TENUTA
 AUTOMATIC QUICK COUPLINGS WITH DOUBLE SHUT-OFF
 KUPPLUNGEN MIT BEIDSEITIGER ABSPERRUNG
 COUPLEURS À DOUBLE OBTURATION
 ENCHUFES RÁPIDOS DE DOBLE OBTURACIÓN
 ENGATE RÁPIDO COM DUPLA RETENÇÃO



CARATTERISTICHE TECNICHE
 TECHNICAL CHARACTERISTICS
 TECHNISCHE ANGABEN
 CARACTÉRISTIQUES TECHNIQUES
 CARACTERÍSTICAS TÉCNICAS
 CARACTERÍSTICAS TÉCNICAS



Norma di Riferimento
 Reference standard
 Entspricht der Norm
 Norme de référence
 Normativa de referencia
 Norma de referência

1907/2006
REACH ✓

2011/65/CE
RoHS ✓

PED
 2014/68/UE

SILICON
 FREE

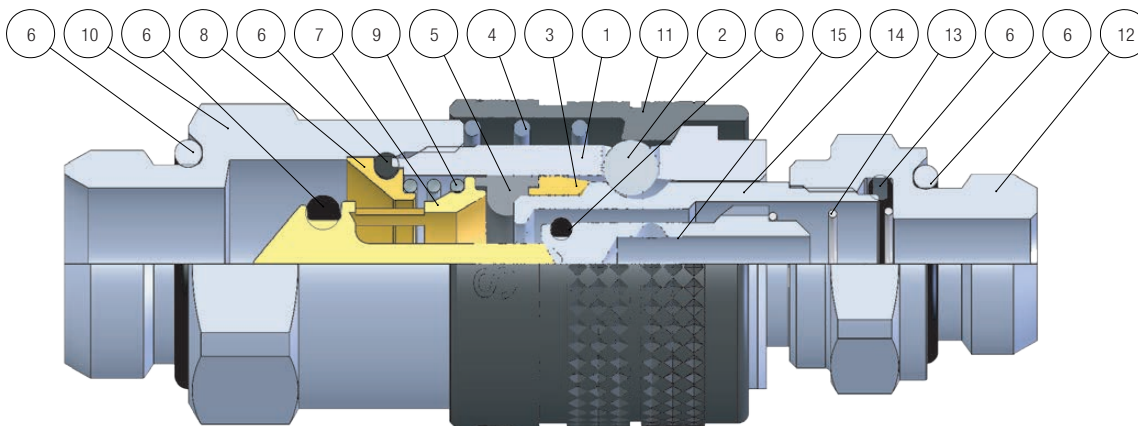

FKM A RICHIESTA
 IF REQUESTED FKM
 FKM AUF ANFRAGE
 FKM SUR DEMANDE
 FKM BAJO DEMANDA
 FKM SOB ENCOMENDA

DN
 7.8 mm

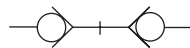

EUROPEAN

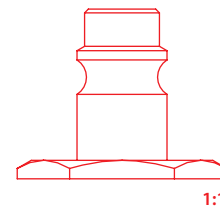

| Materiali e Componenti | IT | Component Parts and Materials | GB | Komponenten und Materialien | DE |
|--|----|--|----|---|----|
| 1 Corpo in Ottone Nichelato | | 1 Nickel-Plated Brass Body | | 1 Körper Messing Vernickelt | |
| 2 Sfera in Acciaio AISI 420 | | 2 Stainless Steel AISI 420 Balls | | 2 Kugel Edelstahl AISI 420 | |
| 3 Anello Guida Innesto in Ottone Nichelato | | 3 Nickel-Plated Brass Guide Ring Coupling | | 3 Stecker Führungsring Messing Vernickelt | |
| 4 Molla Ghiera in Acciaio AISI 302 | | 4 Stainless Steel AISI 302 Ring Nut Spring | | 4 Entriegelungsfeder Edelstahl AISI 302 | |
| 5 Guarnizione Innesto Sagomata in NBR | | 5 NBR Plug Molded Seals | | 5 O-Ring NBR | |
| 6 Guarnizione O-Ring in NBR | | 6 NBR O-Ring Seals | | 6 O-Ring NBR | |
| 7 Otturatore in Ottone | | 7 Brass Shutter | | 7 Verschluss Messing | |
| 8 Anello in Ottone | | 8 Brass Ring | | 8 Ring Messing | |
| 9 Molla Otturatore Presa in Acciaio AISI 302 | | 9 Stainless Steel AISI 302 Shutter Spring | | 9 Verschlussfeder Edelstahl AISI 302 | |
| 10 Attacco Terminale in Ottone Nichelato | | 10 Nickel-Plated Brass Coupling Back Part | | 10 Einschraubkörper Messing Vernickelt | |
| 11 Ghiera in Ottone Zincato Nero | | 11 Black Zinc Plated Brass Sleeve | | 11 Entriegelungshülse Messing Schwarze Zink | |
| 12 Innesto in Ottone Nichelato | | 12 Nickel-Plated Brass Plug Outline | | 12 Stecker Messing Vernickelt | |
| 13 Molla Otturatore Innesto AISI 302 | | 13 Stainless Steel AISI 302 Shutter Spring | | 13 Verschlussfeder Edelstahl AISI 302 | |
| 14 Profilo Innesto Ottone Nichelato | | 14 Nickel-Plated Brass Profile Plug | | 14 Stecker Messing Vernickelt | |
| 15 Otturatore Innesto Ottone Nichelato | | 15 Nickel-Plated Brass Shutter | | 15 Verschluss Messing Vernickelt | |

| Matériaux et Composants | FR | Materialies y Componentes | ES | Materialies e Componentes | PT |
|---|----|--|----|--|----|
| 1 Corps: Laiton Nickelé | | 1 Cuerpo en latón niquelado | | 1 Corpo em Latão Niquelado | |
| 2 Bille: Acier Inoxydable AISI 420 | | 2 Esfera en acero AISI 420 | | 2 Esfera em aço AISI 420 | |
| 3 Bague de Guidage: Laiton Nickelé | | 3 Anillo guía enchufe en latón niquelado | | 3 Anel guia do plug em latão niquelado | |
| 4 Ressort de Bague: Acier Inoxydable AISI 302 | | 4 Muelle tuerca en acero AISI 302 | | 4 Mola da porca em aço AISI 302 | |
| 5 Joint Torique en NBR | | 5 Tapón obturador sagomata NBR | | 5 Vedações em NBR moldada para plug | |
| 6 Joint Torique en NBR | | 6 Junta tórica en NBR | | 6 Vedação O-Ring em NBR | |
| 7 Clapet: Laiton | | 7 Obturador en latón | | 7 Obturador em latão | |
| 8 Bague en Laiton | | 8 Anillo en latón | | 8 Anel em latão | |
| 9 Ressort de Clapet: Acier Inoxydable AISI 302 | | 9 Muelle obturador en acero AISI 302 | | 9 Mola do obturador em aço AISI 302 | |
| 10 Corps: Laiton Nickelé | | 10 Terminal de conexión en latón niquelado | | 10 Conexão terminal em latão niquelado | |
| 11 Bague: Laiton Zinc Noir | | 11 Tuerca en latón Zinc Negro | | 11 Porca em latão zinco preto | |
| 12 Embout: Laiton Nickelé | | 12 Enchufe en latón niquelado | | 12 Plug em latão niquelado | |
| 13 Ressort de Clapet: Acier Inoxydable AISI 302 | | 13 Muelle obturador en acero AISI 302 | | 13 Mola do obturador em aço AISI 302 | |
| 14 Embout: Laiton Nickelé | | 14 Perfil enchufe en latón niquelado | | 14 Perfil plug em latão niquelado | |
| 15 Clapet: Laiton Nickelé | | 15 Obturador en latón niquelado | | 15 Obturador em latão niquelado | |



Pressione d'esercizio

Working Pressures

Betriebsdruck

Pression de service

Presión de Ejercicio

Pressão de Trabalho

16 bar



Max pressione statica (no pulsazioni)

Maximum static pressure (no pulsations)

Maximaler statischer Betriebsdruck (ohne pulsations)

Pression statique maximale (sans pulsation)

Presión estática máxima (sin pulsaciones)

Pressão estática máxima (sem pulsações)

35 bar



Temperature

Temperatures

Temperatur

Températures

Temperaturas

Temperaturas

- 20 °C

+ 80 °C

Con Guarnizioni FKM

With FKM Seals

Mit FKM Dichtung

Avec joints FKM

Con juntas FKM

Com Vedação em FKM

- 10 °C

+ 200 °C



Fluidi compatibili

Aria compressa / Acqua

Fluids

Compressed air / Water

Geeignete Medien

Druckluft / Wasser

Fluides compatibles

Air comprimé / Eau

Fluidos compatibles

Aire comprimido / Agua

Fluidos compatíveis

Ar comprimido / Agua



Portata

NI/min

Flow Rate

Durchflusswerte

Débit

Caudal de Flujo

Vazão

| 6 bar Δ 1 | 6 bar Δ 0.5 | 6 bar * |
|--------------|----------------|------------|
| 590 | 460 | 830 |

* Scarico libero - Exhaust Free - Freier Auslass - Échappement libre - Escape Libre - Descarga livre.



Filettatura

IT

Gas cilindrica conforme ISO 228 Classe A.

Threads

GB

Parallel gas in conformity with ISO 228 Class A.

Gewindearten

DE

Zylindrisches Gewinde nach Norm ISO 228 Classe A.

Filetages

FR

Filetage cylindrique conforme: ISO 228 Class A.

Roscas

ES

Gas cilindrica conforme ISO 228 Clase A.

Roscas

PT

Gas paralela conforme ISO 228 Classe A.

741

PRESA MASCHIO CILINDRICO CON OR

MALE CYLINDRIC SOCKET WITH OR
 VERSCHLUSS-KUPPLUNG MIT AUSSENGEWINDE ZYLINDRISCH MIT OR
 COUPLEUR MÂLE CYLINDRIQUE AVEC OR
 ENCHUFE MACHO CILINDRICA CON OR
 SOQUETE COM ROSCA MACHO PARALELA COM OR

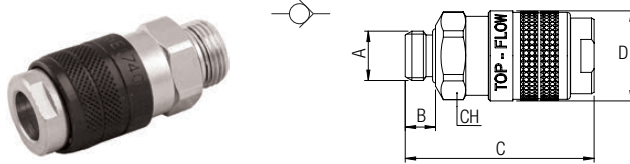

| Code | A | B | C | D | CH | Pack. |
|--------------|-----|----|------|----|----|-------|
| 00741 00 002 | 1/4 | 8 | 49.5 | 24 | 21 | 10 |
| 00741 00 003 | 3/8 | 9 | 50.5 | 24 | 21 | 10 |
| 00741 00 004 | 1/2 | 10 | 51.5 | 24 | 25 | 10 |
| Code FKM | | | | | | |
| 00741 V0 002 | 1/4 | 8 | 49.5 | 24 | 21 | 10 |
| 00741 V0 003 | 3/8 | 9 | 50.5 | 24 | 21 | 10 |
| 00741 V0 004 | 1/2 | 10 | 51.5 | 24 | 25 | 10 |

742

PRESA FEMMINA

FEMALE SOCKET
 VERSCHLUSS-KUPPLUNG MIT INNENGEWINDE
 COUPLEUR FEMELLE
 ENCHUFE HEMBRA
 SOQUETE COM ROSCA FÊMEA

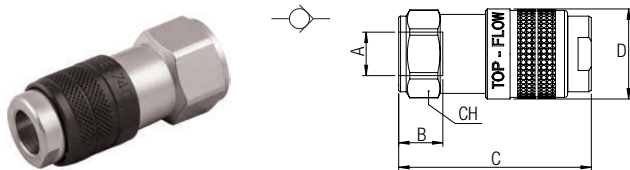

| Code | A | B | C | D | CH | Pack. |
|--------------|-----|----|------|----|----|-------|
| 00742 00 002 | 1/4 | 12 | 50.5 | 24 | 21 | 10 |
| 00742 00 003 | 3/8 | 12 | 51.5 | 24 | 21 | 10 |
| 00742 00 004 | 1/2 | 15 | 56 | 24 | 24 | 10 |
| Code FKM | | | | | | |
| 00742 V0 002 | 1/4 | 12 | 50.5 | 24 | 21 | 10 |
| 00742 V0 003 | 3/8 | 12 | 51.5 | 24 | 21 | 10 |
| 00742 V0 004 | 1/2 | 15 | 56 | 24 | 24 | 10 |

841

INNESTO MASCHIO CILINDRICO CON OR

MALE PLUG (PARALLEL) WITH OR
 STECKER MIT AUSSENGEWINDE KONISCH MIT OR
 EMBOUT MÂLE AVEC OR
 ADAPTADOR MACHO CILÍNDRICO CON OR
 PLUG COM ROSCA MACHO PARALELA COM OR

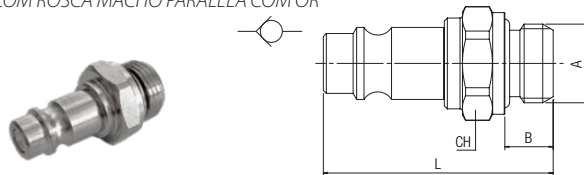

| Code | A | B | L | CH | Pack. |
|--------------|-----|----|----|----|-------|
| 00841 00 002 | 1/4 | 8 | 38 | 17 | 10 |
| 00841 00 003 | 3/8 | 9 | 39 | 20 | 10 |
| 00841 00 004 | 1/2 | 10 | 42 | 25 | 10 |
| Code FKM | | | | | |
| 00841 V0 002 | 1/4 | 8 | 38 | 17 | 10 |
| 00841 V0 003 | 3/8 | 9 | 39 | 20 | 10 |
| 00841 V0 004 | 1/2 | 10 | 42 | 25 | 10 |

Utilizzare solo con prese per innesti otturati.
 Using only with socket for shutter plug.
 Nur Mit Verschluss-Kupplungen Beidseitig Absperrend Einsetzbar.
 Utilisable avec pleurico à obturation.
 Utilizar solo con enchufes para adaptador obturado.
 Utilizar somente com soquete para plug com retenção.

842

INNESTO FEMMINA

FEMALE PLUG
 STECKER MIT INNENGEWINDE
 EMBOUT FEMELLE
 ADAPTADOR HEMBRA
 PLUG COM ROSCA FÊMEA

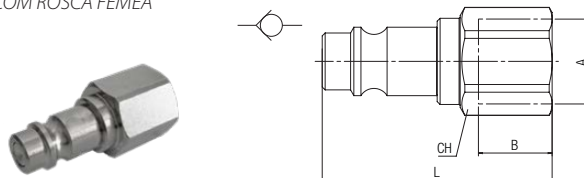

| Code | A | B | L | CH | Pack. |
|--------------|-----|----|------|----|-------|
| 00842 00 002 | 1/4 | 11 | 40.5 | 17 | 10 |
| 00842 00 003 | 3/8 | 12 | 42.5 | 19 | 10 |
| 00842 00 004 | 1/2 | 15 | 46.5 | 24 | 10 |
| Code FKM | | | | | |
| 00842 V0 002 | 1/4 | 11 | 40.5 | 17 | 10 |
| 00842 V0 003 | 3/8 | 12 | 42.5 | 19 | 10 |
| 00842 V0 004 | 1/2 | 15 | 46.5 | 24 | 10 |

Utilizzare solo con prese per innesti otturati.
 Using only with socket for shutter plug.
 Nur Mit Verschluss-Kupplungen Beidseitig Absperrend Einsetzbar.
 Utilisable avec pleurico à obturation.
 Utilizar solo con enchufes para adaptador obturado.
 Utilizar somente com soquete para plug com retenção.

New

SERIE 63740 AISI 316L

GIUNTI AD INNESTO RAPIDO A DOPPIA TENUTA IN ACCIAIO INOX AISI 316L
STAINLESS STEEL AISI 316L AUTOMATIC QUICK COUPLINGS WITH DOUBLE SHUT-OFF
KUPPLUNGEN MIT BEIDSEITIGER ABSPERRUNG AUS ROSTFREIEM STAHL AISI 316L
COUPLEURS À DOUBLE OBTURATION EN ACIER INOXYDABLE AISI 316L
ENCHUFES RÁPIDOS DE DOBLE OBTURACIÓN EN ACERO INOX AISI 316L
ENGATES RÁPIDOS COM DUPLA RETENÇÃO EM AÇO INOX AISI 316L



CARATTERISTICHE TECNICHE
 TECHNICAL CHARACTERISTICS
 TECHNISCHE ANGABEN
 CARACTÉRISTIQUES TECHNIQUES
 CARACTERÍSTICAS TÉCNICAS
 CARACTERÍSTICAS TÉCNICAS



Norma di Riferimento
 Reference standard
 Entspricht der Norm
 Norme de référence
 Normativa de referencia
 Norma de referência

1907/2006
REACH ✓

2011/65/CE
RoHS ✓

PED
 2014/68/EU

SILICON FREE

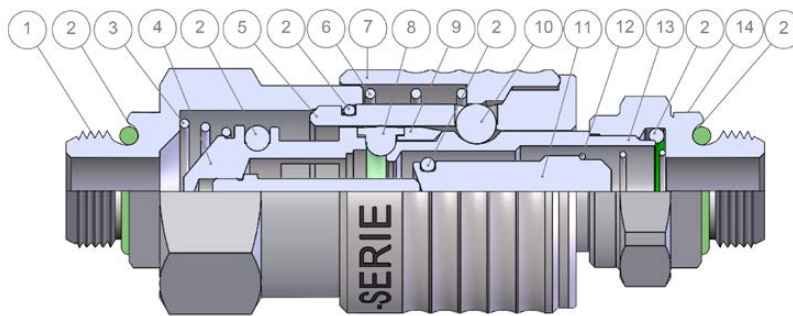

DN
7.8 mm

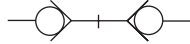

EUROPEAN

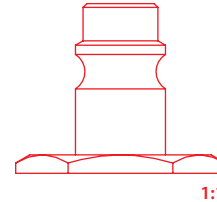

| Materiali e Componenti | IT | Component Parts and Materials | GB | Komponenten und Materialien | DE |
|--|----|---|----|---|----|
| 1 Attacco terminale In Acciaio Inox AISI 316L | | 1 Stainless steel AISI 316L end connection | | 1 Endanschluss aus rostfreiem Stahl AISI 316L | |
| 2 Guarnizione In FKM | | 2 FKM Gasket | | 2 FKM Dichtung | |
| 3 Molla Otturatore Presa In Acciaio AISI 302 | | 3 AISI 302 stainless steel plug spring | | 3 Kegelfeder aus Edelstahl AISI 302 | |
| 4 Otturatore In Acciaio Inox AISI 316L | | 4 AISI 316L stainless steel plug | | 4 Kegel aus Edelstahl AISI 316L | |
| 5 Corpo In Acciaio Inox AISI 316L | | 5 AISI 316L Stainless Steel Body | | 5 Gehäuse aus Edelstahl AISI 316L | |
| 6 Molla Ghiera In Acciaio AISI 302 | | 6 AISI 302 Stainless Steel Ring Spring | | 6 Ringfeder aus Edelstahl AISI 302 | |
| 7 Ghiera In Acciaio Inox AISI 316L | | 7 AISI 316L stainless steel ring nut | | 7 Ringmutter aus rostfreiem Stahl AISI 316L | |
| 8 Guarnizione Innesto Sagomata In FKM | | 8 Shaped FKM coupling gasket | | 8 Geformte FKM-Kupplungsdichtung | |
| 9 Anello Guida Innesto In Acciaio Inox AISI 316L | | 9 AISI 316L Stainless Steel Clutch Guide Ring | | 9 Kupplungsführungsring aus Edelstahl AISI 316L | |
| 10 Sfera In Acciaio Aisi 420 | | 10 AISI 420 Stainless Steel Ball | | 10 Kugel aus rostfreiem Stahl AISI 420 | |
| 11 Otturatore Innesto In Acciaio Inox AISI 316L | | 11 AISI 316L stainless steel plug | | 11 Stopfen aus Edelstahl AISI 316L | |
| 12 Molla Otturatore Innesto AISI 302 | | 12 AISI 302 Stainless Steel plug spring | | 12 Steckerfeder aus Edelstahl AISI 302 | |
| 13 Profilo Innesto In Acciaio Inox AISI 316L Terminale | | 13 AISI 316L stainless steel plug profile End cap | | 13 Steckerprofil aus Edelstahl AISI 316L Endkappe | |
| 14 Innesto In Acciaio Inox AISI 316L | | 14 AISI 316L stainless steel plug | | 14 Stopfen aus Edelstahl AISI 316L | |

| Matériaux et Composants | FR | Materiales y Componentes | ES | Materiais e Componentes | PT |
|--|----|--|----|--|----|
| 1 Raccord d'extrémité en acier inoxydable AISI 316L | | 1 Conexión final de acero inoxidable AISI 316L | | 1 Conexão de extremidade em aço inoxidável AISI 316L | |
| 2 Joint en FKM | | 2 Junta de FKM | | 2 Anel de vedação FKM | |
| 3 Ressort de bouchon en acier inoxydable AISI 302 | | 3 Resorte del tapón de acero inoxidable AISI 302 | | 3 Mola do plugue em aço inoxidável AISI 302 | |
| 4 Bouchon en acier inoxydable AISI 316L | | 4 Tapón de acero inoxidable AISI 316L | | 4 Tampão de aço inoxidável AISI 316L | |
| 5 Corps en acier inoxydable AISI 316L | | 5 Cuerpo de acero inoxidable AISI 316L | | 5 Corpo em aço inoxidável AISI 316L | |
| 6 Ressort de bague en acier inoxydable AISI 302 | | 6 Resorte anular de acero inoxidable AISI 302 | | 6 Mola do anel em aço inoxidável AISI 302 | |
| 7 Écrou de bague en acier inoxydable AISI 316L | | 7 Tuerca anular de acero inoxidable AISI 316L | | 7 Porca do anel em aço inoxidável AISI 316L | |
| 8 Joint d'accouplement façonné en FKM | | 8 Junta de acoplamiento moldeada de FKM | | 8 Junta de acoplamento FKM moldada | |
| 9 Bague de guidage d'embrayage en acier inoxydable AISI 316L | | 9 Anillo guía del embrague de acero inoxidable AISI 316L | | 9 Anel de guia da embreagem em aço inoxidável AISI 316L | |
| 10 Bille en acier inoxydable AISI 420 | | 10 Bola de acero inoxidable AISI 420 | | 10 Esfera de aço inoxidável AISI 420 | |
| 11 Bouchon en acier inoxydable AISI 316L | | 11 Tapón de acero inoxidable AISI 316L | | 11 Tampão de aço inoxidável AISI 316L | |
| 12 Ressort de clapet en acier inoxydable AISI 302 | | 12 Muelle del obturador de acero inoxidable AISI 302 | | 12 Mola do plugue em aço inoxidável AISI 302 | |
| 13 Profil du plugue en acier inoxydable AISI 316L Capuchon d'extrémité | | 13 Tapón de cierre de acero inoxidable AISI 316L | | 13 Perfil do plugue em aço inoxidável AISI 316L Tampa da extremidade | |
| 14 Bouchon en acier inoxydable AISI 316L | | 14 Tapón de acero inoxidable AISI 316L | | 14 Plugue de aço inoxidável AISI 316L | |



Pressione d'esercizio

Working Pressures

Betriebsdruck

Pression de service

Presión de Ejercicio

Pressão de Trabalho

16 bar



Max pressione statica (no pulsazioni)

Maximum static pressure (no pulsations)

Maximaler statischer Betriebsdruck (ohne pulsations)

Pression statique maximale (sans pulsation)

Presión estática máxima (sin pulsaciones)

Pressão estática máxima (sem pulsações)

35 bar



Temperature

Temperatures

Temperatur

Températures

Temperaturas

Temperaturas

- 10 °C

+ 200 °C



Fluidi compatibili

Aria compressa

Fluidi per Industria alimentare e chimica compatibili con i componenti.

Fluids

Compressed air

Fluid for food and chemical industry compatible with all components.

Geeignete Medien

Druckluft

Medien für die Lebensmittel- und chemische Industrie, die beständig mit den Komponenten der Verschraubungen sind.

Fluides compatibles

Air comprimé

Fluides alimentaires et chimiques compatibles avec les matériaux constituant les raccords.

Fluidos compatibles

Aire comprimido

Fluidos para industria alimentaria y química compatibles con los componentes del racor.

Fluidos compatíveis

Ar comprimido

Fluidos para Indústria alimentícia e química compatíveis com os componentes da conexão.



Portata

NI/min

Flow Rate

Durchflusswerte

Débit

Caudal de Flujo

Vazão

| 6 bar Δ 1 | 6 bar Δ 0.5 | 6 bar * |
|--------------|----------------|------------|
| 560 | 440 | 780 |

* Scarico libero - Exhaust Free - Freier Auslass - Échappement libre - Escape Libre - Descarga livre.



Filettatura

IT

Gas conica "UNIVERSAL SHORT".
Gas cilindrica conforme ISO 228 Classe A.

Threads

GB

"UNIVERSAL SHORT" Tapered thread.
Parallel gas in conformity with ISO 228 Class A.

Gewindearten

DE

Konisches Gewinde "UNIVERSAL SHORT".
Zylindrisches Gewinde nach Norm ISO 228 Classe A.

Filetages

FR

Filetage conique "UNIVERSAL SHORT".
Filetage cylindrique conforme: ISO 228 Classe A.

Roscas

ES

Gas cónica "UNIVERSAL SHORT".
Gas cilíndrica conforme ISO 228 Clase A.

Roscas

PT

Gas cônica "UNIVERSAL SHORT".
Gas paralela conforme ISO 228 Classe A.

63740

PRESA MASCHIO "UNIVERSAL SHORT" OTTURATA

MALE SOCKET "UNIVERSAL SHORT" FOR SHUTTER PLUG
 KUPPLUNG MIT AUSSENGEWINDE "UNIVERSAL SHORT" FÜR STECKER ABSPERREND
 COUPLEUR MÂLE "UNIVERSAL SHORT" AVEC OBTURATION
 ENCHUFE MACHO "UNIVERSAL SHORT" PARA ADAPTADOR OBTURADO
 SOQUETE COM ROSCA MACHO TIPO "UNIVERSAL SHORT" PARA PLUG COM RETENÇÃO

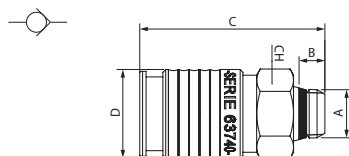

| Code | A | B | C | D | CH | Pack. |
|--------------|-----|-----|------|----|----|-------|
| 63740 00 002 | 1/4 | 7 | 50.2 | 24 | 21 | 2 |
| 63740 00 003 | 3/8 | 7.5 | 50.7 | 24 | 21 | 2 |
| 63740 00 004 | 1/2 | 9 | 52.2 | 24 | 21 | 2 |

***Fino ad esaurimento scorta**

**Until the end stock*

**Nur solange vorrat*

**Livvable jusqu'à épuisement du stock*

**Hasta fin de stock*

**Ate fim do stock*

63741

PRESA MASCHIO CILINDRICO CON OR OTTURATA

MALE SOCKET WITH CYLINDRICAL THREAD AND SEALED O-RING
 KUPPLUNG MIT ZYLINDRISCHEM AUSSENGEWINDE UND ABGEDICHTETEM O-RING
 COUPLEUR MÂLE À FILETAGE CYLINDRIQUE AVEC OBTURATION ET JOINT TORIQUE
 ENCHUFE MACHO CON ROSCA CILÍNDRICA Y JUNTA TÓRICA OBTURADA
 SOQUETE MACHO COM ROSCA CILÍNDRICA E O-RING OBTURADO

New

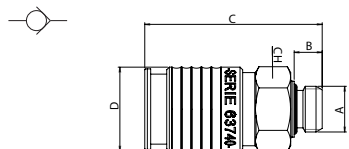

| Code | A | B | C | D | CH | Pack. |
|--------------|-----|----|------|----|----|-------|
| 63741 00 002 | 1/4 | 8 | 50.7 | 24 | 21 | 2 |
| 63741 00 003 | 3/8 | 9 | 52.7 | 24 | 21 | 2 |
| 63741 00 004 | 1/2 | 10 | 53 | 24 | 21 | 2 |

63742

PRESA FEMMINA OTTURATA

FEMALE SOCKET FOR SHUTTER PLUG
 KUPPLUNG MIT INNENGEWINDE FÜR STECKER ABSPERREND
 COUPLEUR FEMELLE AVEC OBTURATION
 ENCHUFE HEMBRA PARA ADAPTADOR OBTURADO
 SOQUETE COM ROSCA FÊMEA PARA PLUG COM RETENÇÃO

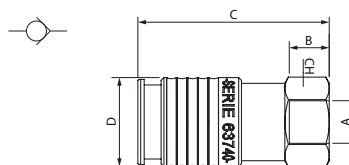

| Code | A | B | C | D | CH | Pack. |
|--------------|-----|------|------|----|----|-------|
| 63742 00 002 | 1/4 | 11 | 51.7 | 24 | 21 | 2 |
| 63742 00 003 | 3/8 | 11.5 | 52.2 | 24 | 21 | 2 |
| 63742 00 004 | 1/2 | 15 | 56.7 | 24 | 24 | 2 |

63840

INNESTO OTTURATO MASCHIO "UNIVERSAL SHORT"

MALE SHUTTER PLUG "UNIVERSAL SHORT"
 STECKER ABSPERREND MIT AUSSENGEWINDE "UNIVERSAL SHORT" EMBOUT
 MÂLE "UNIVERSAL SHORT"; DOUBLE OBTURATIONS
 ADAPTADOR OBTURADO MACHO "UNIVERSAL SHORT"
 PLUG COM RETENÇÃO ROSCA MACHO TIPO "UNIVERSAL SHORT"

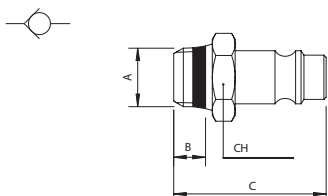

| Code | A | B | C | CH | Pack. |
|--------------|-----|-----|------|----|-------|
| 63840 00 001 | 1/4 | 7 | 36.5 | 17 | 2 |
| 63840 00 002 | 3/8 | 7.5 | 37 | 19 | 2 |
| 63840 00 003 | 1/2 | 9 | 39 | 24 | 2 |

Utilizzare solo con prese per innesti otturati.

Using only with socket for shutter plug.

Nur Mit Verschluss-Kupplungen Beidseitig Absperrend Einsetzbar.

Utilisable avec pleurico à obturation.

Utilizar solo con enchufes para adaptador obturado.

Utilizar somente com soquete para plug com retenção.

***Fino ad esaurimento scorta**

**Until the end stock*

**Nur solange vorrat*

**Livvable jusqu'à épuisement du stock*

**Hasta fin de stock*

**Ate fim do stock*

63841

New



INNESTO OTTURATO MASCHIO CILINDRICO CON OR

SHUTTER MALE CYLINDRICAL FITTING WITH O-RING
 ZYLINDRISCHER BLINDSTECKER MIT O-RING
 EMBOUT MÂLE CYLINDRIQUE OBTURÉ AVEC JOINT TORIQUE
 CONECTOR MACHO CILÍNDRICO OBTURADO CON JUNTA TÓRICA
 CONECTOR MACHO CILÍNDRICO OBTURADO COM O-RING

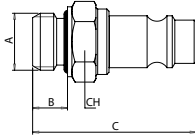

| Code | A | B | C | CH | Pack. |
|--------------|-----|----|------|----|-------|
| 63841 00 001 | 1/4 | 8 | 37.5 | 16 | 2 |
| 63841 00 002 | 3/8 | 9 | 41 | 20 | 2 |
| 63841 00 003 | 1/2 | 10 | 43 | 24 | 2 |

Utilizzare solo con prese per innesti otturati.
 Using only with socket for shutter plug.
 Nur Mit Verschluss-Kupplungen Beidseitig Absperrend Einsetzbar.
 Utilisable avec pleurico à obturation.
 Utilizar solo con enchufes para adaptador obturado.
 Utilizar somente com soquete para plug com retenção.

63842



INNESTO FEMMINA OTTURATO

FEMALE SHUTTER PLUG
 STECKER Absperrend MIT INNENGEWINDE
 EMBOUT FEMELLE, DOUBLE OBTURATIONS
 ADAPTADOR OBTURADO HEMBRA DOUBLE OBTURATIONS
 PLUG COM RETENÇÃO ROSCA FÊMEA TIPO

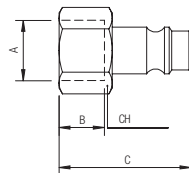

| Code | A | B | L | CH | Pack. |
|--------------|-----|------|------|----|-------|
| 63842 00 001 | 1/4 | 11 | 40 | 17 | 2 |
| 63842 00 002 | 3/8 | 11.5 | 41 | 19 | 2 |
| 63842 00 003 | 1/2 | 15 | 45.5 | 24 | 2 |

Utilizzare solo con prese per innesti otturati.
 Using only with socket for shutter plug.
 Nur Mit Verschluss-Kupplungen Beidseitig Absperrend Einsetzbar.
 Utilisable avec pleurico à obturation.
 Utilizar solo con enchufes para adaptador obturado.
 Utilizar somente com soquete para plug com retenção.

63261 DN 7.8



INNESTO PROFILO EUROPEO MASCHIO CILINDRICO CON OR

EUROPEAN PROFILE MALE CYLINDRICAL SOCKET WITH O-RING
 KUPPLUNG EUROPÄISCHES PROFIL MIT AUSSENGEWINDE UND O-RING
 RACCORD MALE PROFILE EUROPÉEN AVEC JOINT TORIQUE
 ENCHUFE MACHO DE PERFIL EUROPEO CON O-RING
 CONECTOR MACHO DE PERFIL EUROPEO COM O-RING

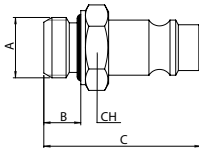

| Code | A | B | C | CH | Pack. |
|--------------|-----|----|------|----|-------|
| 63261 00 002 | 1/4 | 8 | 34 | 16 | 2 |
| 63261 00 003 | 3/8 | 9 | 35.5 | 20 | 2 |
| 63261 00 004 | 1/2 | 10 | 38 | 24 | 2 |

63262 DN 7.8



INNESTO PROFILO EUROPEO FEMMINA

FEMALE PLUG EUROPEAN PROFILE
 STECKER MIT INNENGEWINDE - EUROPEAN
 EMBOUT FEMELLE - PROFIL EUROPEEN
 ADAPTADOR PERFIL EUROPEO HEMBRA
 PLUG COM PERFIL EUROPEU E ROSCA FÊMEA

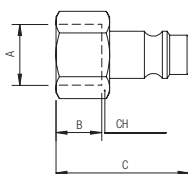

| Code | A | B | C | CH | Pack. |
|-------------------|-----|------|------|----|-------|
| 63262 00 44 03 00 | 1/4 | 11 | 33 | 17 | 2 |
| 63262 00 44 04 00 | 3/8 | 11.5 | 33.5 | 19 | 2 |
| 63262 00 44 05 00 | 1/2 | 15 | 37 | 24 | 2 |