

**VALVOLE ISO 5599 - TAGLIA 1**

*VALVES ISO 5599 - SIZE 1*

*VENTILE ISO 5599 - GRÖBE 1*

*DISTRIBUTEURS A TIROIR ISO 5599 - TAILLE 1*

*VALVULAS ISO 5599 - TAMAÑO 1*

*VALVULAS ISO 5599 - TAMANHO 1*

**Serie 10V**



## VALVOLE ISO 5599 - TAGLIA 1 AD AZIONAMENTO ELETTRICO

VALVES ISO 5599 - SIZE 1 ELETTRICALLY OPERATED  
 VENTILE ISO 5599 - GRÖÖE 1 ELEKTRISCH GESTEUERT  
 DISTRIBUTEURS ELECTROPNEUMATIQUE ISO 5599 TAILLE 1  
 VALVULAS ISO 5599 - TAMAÑO 1 DE ACCIONAMIENTO ELÉCTRICO  
 VALVULAS ISO 5599 - TAMANHO 1 CIONAMENTO ELÉTRICO



### CARATTERISTICHE TECNICHE

TECHNICAL CHARACTERISTICS  
 TECHNISCHE ANGABEN  
 CARACTÉRISTIQUES TECHNIQUES  
 CARACTERÍSTICAS TÉCNICAS  
 CARACTERÍSTICAS TÉCNICAS



### Norma di Riferimento

Reference standard

Entspricht der Norm

Norme de référence

Normativa de referencia

Norma de referència

1907/2006  
 REACH ✓

2011/65/CE  
 RoHS ✓

PED  
 2014/68/UE

ISO 5599  
 SIZE 1



	PORTATA a 6 BAR con $\Delta p$ 1 bar 6 bar FLOW RATE with $\Delta p$ 1 bar DURCHFLOSSWERT BEI 6 bar mit $\Delta p$ 1 bar DÉBIT DE RÉFÉRENCE à 6 bar avec $\Delta p$ 1 bar CAUDAL a 6 BAR con $\Delta p$ 1 bar VAZÃO a 6 BAR com $\Delta p$ 1 bar		1100 NI/min
	PRESSIONE DI FUNZIONAMENTO OPERATING PRESSURE BETRIEBSDRUCK PRESSION DE SERVICE PRESIÓN DE EJERCICIO PRESSÃO DE OPERAÇÃO	Monostable	2.5 ÷ 10 bar
		Bistable	1 ÷ 10 bar
	TEMPERATURA TEMPERATURE BETRIEBSTEMPERATUR TEMPÉRATURE DE TRAVAIL TEMPERATURA TEMPERATURA	min	-10 °C
		max	+60 °C
	POTENZA MINIMA MINIMUM POWER MIN. LEISTUNG PUISSANCE MIN. POTÊNCIA MÍNIMA POTÊNCIA MINIMA		3W - 5VA
	COMANDO MANUALE MANUAL CONTROL MANUELLE BETÄTIGUNG COMMANDE MANUELLE COMANDO MANUAL ACIONAMENTO MANUAL		BISTABILE TWO STABLE POSITIONS BISTABIL BISTABLE BIESTABLE BIESTÁVEL
	TEMPI DI RISPOSTA RESPONSE TIME SCHALTZEITEN TEMPS DE RÉPONSE TIEMPO DE RESPUESTA TEMPOS DE RESPOSTA	Monostable	TRA = 24ms
		Monostable	TRR = 50ms
		Bistable	TRA=TRR = 80ms

**TRA** = Tempo di risposta bobina eccitata  
 Response time with energised coil  
 Schaltzeit einer bestromten Spule  
 Temps de réponse de la bobine sous tension  
 Tiempo de respuesta bobina excitada  
 Tempo de resposta com bobina acionada

**TRR** = Tempo di risposta bobina diseccitata  
 Response time with deenergised coil  
 Schaltzeit einer stromlosen Spule  
 Temps de réponse bobine hors tension  
 Tiempo de respuesta bobina desexcitada  
 Tempos de resposta com bobina desacionada

<b>Materiali e Componenti</b>	<b>IT</b>	<b>Component Parts and Materials</b>	<b>GB</b>	<b>Komponenten und Materialien</b>	<b>DE</b>
1 Corpo in alluminio anodizzato 2 Spola in alluminio nichelato 3 Guarnizioni in NBR		1 Anodised aluminium body 2 Nickel-plated spool 3 NBR seals		1 Aluminiumgehäuse Eloxiert 2 Schieber aus Aluminium Vernickelt 3 Dichtungen aus NBR	
<b>Matériaux et Composants</b>	<b>FR</b>	<b>Materiales y Componentes</b>	<b>ES</b>	<b>Materiais e Componentes</b>	<b>PT</b>
1 Corps en aluminium anodisé 2 Tiroir en aluminium nickelé 3 Joints en NBR		1 Cuerpo en Aluminio Anodizado 2 Corredera en Aluminio Niquelado 3 Juntas en NBR		1 Corpo em Alumínio Anodizado 2 Carretel Alumínio Niquelado 3 Vedação em NBR	

	<b>Tabella dei codici di ordinazione</b>
	<i>Ordering codes</i>
	<i>Bestellschlüssel</i>
	<i>Code de commande</i>
	<i>Tabla de codificación para pedidos</i>
	<i>Tabela de codificação para compra</i>

SERIE	Azionamento <i>Actuation Betätigung Actionnement Accionamiento Acionamento</i>	Riazionamento <i>Reactuation Rückstellung Rappel Reaccionamiento Retorno</i>	Vie <i>Ways Wege Voies Vías Vias</i>	Funzione <i>Function Funktion Fonction Función Funções</i>
-------	---	---	---	---

1 0 V
S
0
7
C C
0 0

**S = Solenoide**  
*Solenoid  
Magnetspule  
Bobine  
Solenóide  
Solenóide*

**0 = Monostabile con ritorno a molla**  
*Monostable spring return  
Monostabil mit federrückstellung  
Monostable à rappel par ressort  
Monoestable con retorno muelle  
Monoestável com retorno por mola*

**1 = Bistabile**  
*Bistable  
Bistabil  
Bistable  
Biestable  
Biestável*

**5 = 5/2**  
**7 = 5/3**

**CC = Centri chiusi**  
*Normally closed  
Mittelstellung geschlossen  
Centre fermé  
Centros cerrados  
Centro fechado*

**OC = Centri aperti**  
*Normally exhausted  
Mittelstellung offen  
Centre ouvert  
Centros abiertos  
Centro-aberto negativo*

**PC = Centri in pressione**  
*Normally pressurized  
Mittelstellung unter Druck  
Centre sous pression  
Centros en presión  
Centro abierto positivo*

**00 = Funzione non contemplata**  
*Function not provided  
Funktion steht nicht zur Verfügung  
Fonction non disponible  
Función no contemplada  
Função não contemplada*

## SOLENOIDI + CONNETTORI

*SOLENOIDS + CONNECTOR  
SPULEN + STECKER  
BOBINES + CONNECTEURS  
BOBINAS + CONECTORES  
SOLENÓIDES + CONECTOR*

## VEDI PAG: 17.205/17.211

*SEE PAGE: 17.205/17.211  
SIEHE SEITE: 17.205/17.211  
VOIR PAG: 17.205/17.211  
VER PÁG: 17.205/17.211  
VER PÁG: 17.205/17.211*

**5/2 Vie** - Ways - Wege - Voies - Vías - Vias

**MONOSTABILE CON RITORNO A MOLLA**

MONOSTABLE SPRING RETURN  
 MONOSTABIL MIT FEDERRÜCKSTELLUNG  
 MONOSTABLE À RAPPEL PAR RESSORT  
 MONOESTABLE CON RETORNO POR MUELLE  
 MONOESTÁVEL COM RETORNO POR MOLA

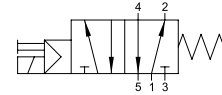

Codice Code Nummer Code Código	Vie Ways Wege Voies Vías Vias	Pack.
10V S0 5 00 00	5/2	1

**5/2 Vie** - Ways - Wege - Voies - Vías - Vias

**BISTABILE**

TWO STABLE POSITIONS  
 BISTABIL  
 BISTABLE  
 BIESTABLE  
 BIESTÁVEL

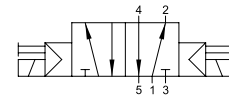

Codice Code Nummer Code Código	Vie Ways Wege Voies Vías Vias	Pack.
10V S1 5 00 00	5/2	1

10V S0 5 00 00

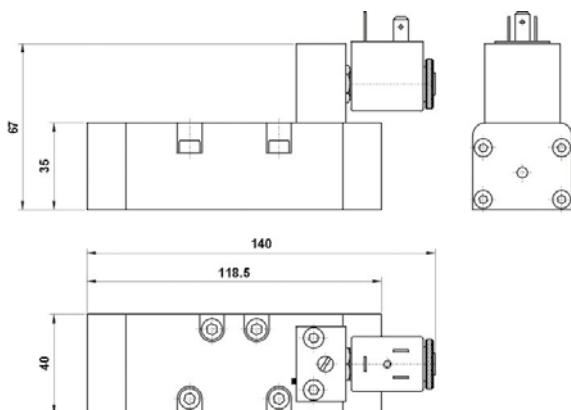

10V S1 5 00 00

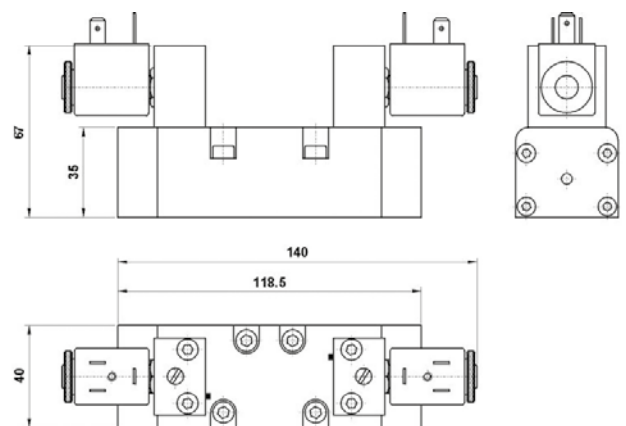

**5/3 Vie** - Ways - Wege - Voies - Vías - Vias

**MONOSTABILE CON RITORNO A MOLLA**

MONOSTABLE SPRING RETURN  
 MONOSTABIL MIT FEDERRÜCKSTELLUNG  
 MONOSTABLE À RAPPEL PAR RESSORT  
 MONOESTABLE CON RETORNO POR MUELLE  
 MONOESTÁVEL COM RETORNO POR MOLA



Codice Code Nummer Code Código Código	Vie Ways Wege Voies Vías Vias	Funzione Function Funktion Fonction Función Funções	Pack.
<b>10V S0 7 CC 00</b>	5/3	<b>CC</b>	1
<b>10V S0 7 OC 00</b>	5/3	<b>OC</b>	1
<b>10V S0 7 PC 00</b>	5/3	<b>PC</b>	1

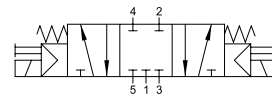

**CC**

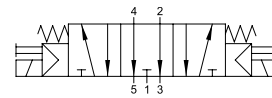

**OC**

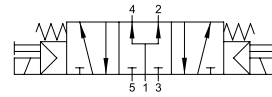

**PC**

**10V S0 7 OC 00    10V S0 7 CC 00    10V S0 7 PC 00**

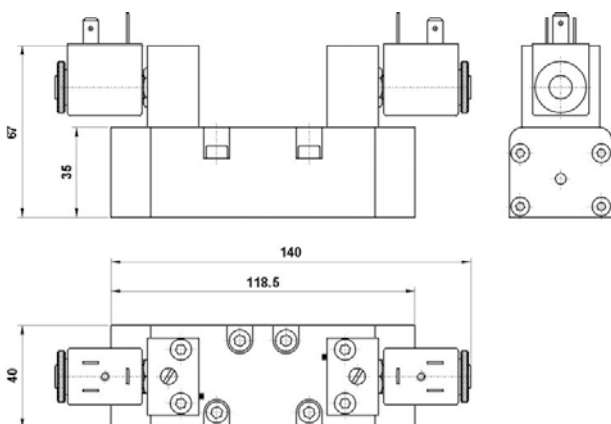

**SERIE 10V**

**BASI MODULARI**

MODULAR BASES  
 MODULARE GRUNDPLATTEN  
 EMBASES MODULAIRES  
 BASE MODULAR  
 BASES MODULARES



**CARATTERISTICHE TECNICHE**

TECHNICAL CHARACTERISTICS  
 TECHNISCHE ANGABEN  
 CARACTÉRISTIQUES TECHNIQUES  
 CARACTERÍSTICAS TÉCNICAS  
 CARACTERÍSTICAS TÉCNICAS



**Norma di Riferimento**

Reference standard

Entspricht der Norm

Norme de référence

Normativa de referencia

Norma de referència

1907/2006  
 REACH ✓

2011/65/CE  
 RoHS ✓

PED  
 2014/68/UE

ISO 5599  
 SIZE 1

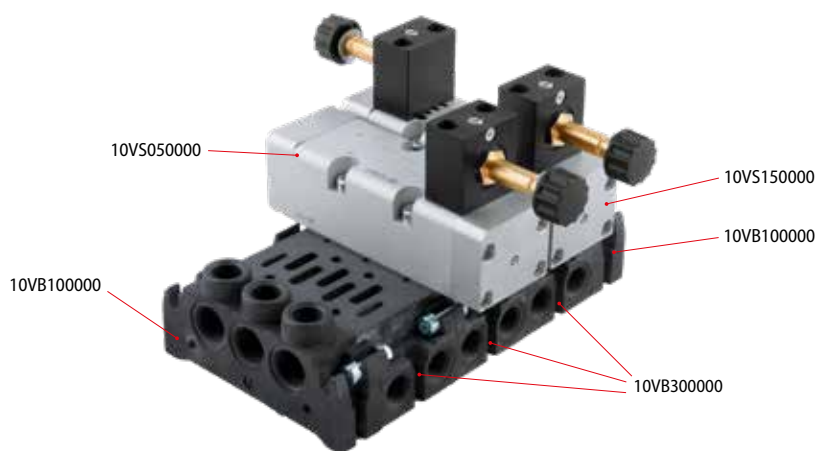

<p><b>IT</b></p> <p>Tutti i moduli e accessori sono completi di viti e guarnizioni per un corretto montaggio.</p>	<p><b>GB</b></p> <p>All the bases are supplied with screws and seals to secure the correct assembly.</p>	<p><b>DE</b></p> <p>Alle Module und Zubehör werden komplett mit Schrauben und Dichtungen für eine ordnungsgemäße Montage geliefert.</p>
<p><b>FR</b></p> <p>Tous les modèles et les accessoires sont équipés avec des vis et des joints d'étanchéité pour une installation correcte.</p>	<p><b>ES</b></p> <p>Todos los módulos y accesorios se suministran con tornillos y juntas para un correcto montaje.</p>	<p><b>PT</b></p> <p>Todos os módulos e acessórios incluem parafusos e vedações para uma montagem correta.</p>

## 10VB1

### TERMINALE DI ALIMENTAZIONE

FRONT TERMINAL  
FRONT-GRUNDPLATTE  
EMBASE D'ALIMENTATION  
TERMINAL ANTERIOR  
TERMINAL FRONTAL



Code	Pack.
10V B1 0 00 00	2

## 10VB3

### BASE MODULARE

MODULAR BASE  
ZWISCHEN-GRUNDPLATTEN  
EMBASES INTERMÉDIAIRES  
BASE MODULAR  
BASE MODULAR



Code	Pack.
10V B3 0 00 00	1

## 10VB5

### BASE SINGOLA

INDIVIDUAL BASE  
EINZEL-GRUNDPLATTEN  
EMBASE UNITAIRE  
BASE SIMPLE  
BASE INDIVIDUAL



Code	Pack.
10V B5 0 00 00	1

## 10VB9

### PIASTRA DI CHIUSURA

CLOSING PLATE  
ABSCHLUSSPLATTE  
PLAQUE DE FERMETURE  
PLACA DE CIERRE  
PLACA CEGA



Code	Pack.
10V B9 0 00 00	1

