

Cilindro elettrico per motore in linea

Electric Actuator for In-line motor mount
Elektrischer Zylinder für Inline Motor
Verin électrique pour moteur en ligne
Cilindro eléctrico para motor en línea
Cilindro eléctrico para motor em linha

Ø 32-63 mm



Serie H

Pag. 19.9

Cilindro elettrico per motore in parallelo

Electric Actuator for parallel motor mount
Elektrischer Zylinder für paralleler motorbefestigung
Verin électrique pour moteur en parallele
Cilindro eléctrico para motor en paralelo
Cilindro eléctrico para motor em paralelo

Ø 32-63 mm



Serie G

Pag. 19.10

Cilindro elettrico con motore in linea

Electric Actuator with In-line motor mount
Elektrischer Zylinder mit Inline Motor
Verin électrique avec moteur en ligne
Cilindro eléctrico con motor en línea
Cilindro eléctrico com motor em linha

Ø 32-63 mm



Serie H

Pag. 19.14

Cilindro elettrico con motore in parallelo

Electric Actuator with parallel motor mount
Elektrischer Zylinder mit paralleler motorbefestigung
Verin électrique avec moteur en parallele
Cilindro eléctrico con motor en paralelo
Cilindro eléctrico com motor em paralelo

Ø 32-63 mm



Serie G

Pag. 19.15

Motori brushless

Brushless motors
Bürstenloser motor
Moteurs brushless
Motore brushless
Motores sem escova



Motors

Pag. 19.19

Servoazionamenti

Servo motor
Servo Motor
Servo variateur
Servo-accionamiento
Servo-acionamento



Serie SA

Pag. 19.24

Accessori per Cilindri

Accessories for Cylinders
Befestigungselemente für Zylinder
Accessoires pour Vérins
Accesorios para Cilindros
Accesorios para Cilindros

ISO 15552 - Ø 32-63 mm

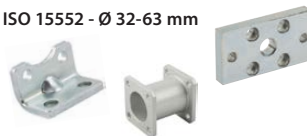

Accessories

Pag. 19.30

Sensori

Sensors
Sensoren
Capteurs
Sensores
Sensores



Sensors

Pag. 19.39

CILINDRI ELETTRICI

ELECTRIC ACTUATORS

ELEKTRISCHE ZYLINDER

VERINS ELECTRIQUES

CILINDROS ELÉCTRICOS

CILINDROS ELÉTRICOS



Serie Electric Actuators

IT

La nuova gamma di cilindri elettrici è frutto di una costante ricerca e sviluppo di Aignep.

La necessità di alcune applicazioni dove la velocità, precisione e costante controllo della posizione, ha fatto sì che Aignep realizzasse una nuova linea di cilindri elettrici.

Principali vantaggi

- Intercambiabilità con cilindri pneumatici ISO 15552
- Velocità di movimento
- Precisione
- Controllo di posizionamento
- Posizionamento multiplo
- Semplificazione dell'impianto
- Antirotazione

Applicazioni

- Automazione Pneumatica, Robotica e manipolazione
- Automotive Process
- Industria tessile, imballaggio, farmaceutica, pesante
- Food Process

GB

The new range of electric actuators is the result of constant research and development by Aignep.

The need for speed, precision and constant positional control for some applications convinced Aignep to produce a new line of electric actuators.

Main advantages

- Interchangeable with ISO 15552 pneumatic cylinders
- Movement velocity
- Accuracy
- Positioning control
- Multiple positioning
- Easier installation
- Anti-rotation

Applications

- Pneumatic Automation, Robotics and handling
- Automotive Process
- Textile, packaging, pharmaceutical, and heavy industry
- Food processing

DE

Die neue Produktreihe der elektrischen Stellantriebe ist das Ergebnis ständiger Forschung und Entwicklung von Aignep.

Der Bedarf an Geschwindigkeit, Präzision und präziser Positionierung, hat Aignep überzeugt, eine neue Serie elektrischer Zylinder zu entwickeln.

Hauptvorteile

- Austauschbar mit pneumatischen Zylindern nach ISO 15552
- Steuerung der Geschwindigkeit
- Genauigkeit
- Steuerung der Positionierung
- Mehrfache Positionierung
- Leichte Installation
- Verdrehgesichert

Anwendungen

- Pneumatische Automatisierung, Robotik und Handhabung
 - Automobil Prozess
 - Textil, Verpackungs, Pharma und Schwerindustrie
 - Lebensmittelverarbeitung
- 

FR

La nouvelle gamme d'actionneurs électriques est le résultat de recherche et développement constants par Aignep.

Le besoin de vitesse, de précision et d'un contrôle de position constante pour certaines applications a conforté Aignep de produire une nouvelle gamme d'actionneurs électriques.

Principaux avantages

- Interchangeabilité avec les vérins pneumatiques ISO 15552
- Vitesse de déplacement
- Précision
- Contrôle de positionnement
- Positionnement multiple
- Installation aisée
- Anti-rotation

Applications

- Automatismes Pneumatiques, Robotique et Manutention
- Process automobile
- Textile, emballage, pharmaceutique et industrie lourde
- Industrie agro alimentaire

ES

La nueva gama de cilindros eléctricos es fruto de una constante búsqueda y desarrollo de Aignep.

La necesidad en alguna aplicación donde la velocidad, precisión y constante control de la posición, a hecho que Aignep realice una nueva línea de cilindros eléctricos.

Principales ventajas

- Intercambiabilidad con el cilindro neumático ISO 15552
- Velocidad de movimiento
- Precisión
- Control de la posición
- Posicionamiento múltiple
- Simplificación del sistema
- Antirrotación

Aplicaciones

- Automatización neumática, robótica y manipulación
- Procesos industria automoción
- Textil, embalaje, farmacéutica, industria pesada
- Procesos industria alimentaria

PT

A nova gama de cilindros elétricos é fruto da constante pesquisa e desenvolvimento da Aignep.

As aplicações onde são necessários velocidade, precisão e controle de posição constante, levaram a Aignep a desenvolver uma nova linha de cilindros elétricos.

Principais vantagens

- Intercambiabilidade com cilindros pneumáticos ISO 15552
- Velocidade de movimentação
- Precisão
- Controle de posicionamento
- Posicionamento múltiplo
- Simplificação da instalação
- Anti-rotação

Aplicações

- Automação Pneumática, Robótica e manipulação
- Processos Automotivos
- Indústria têxtil, embalagem, farmacéutica, pesada
- Processos Alimentícios



CARATTERISTICHE TECNICHE
 TECHNICAL CHARACTERISTICS
 TECHNISCHE ANGABEN
 CARACTÉRISTIQUES TECHNIQUES
 CARACTERÍSTICAS TÉCNICAS
 CARACTERÍSTICAS TÉCNICAS

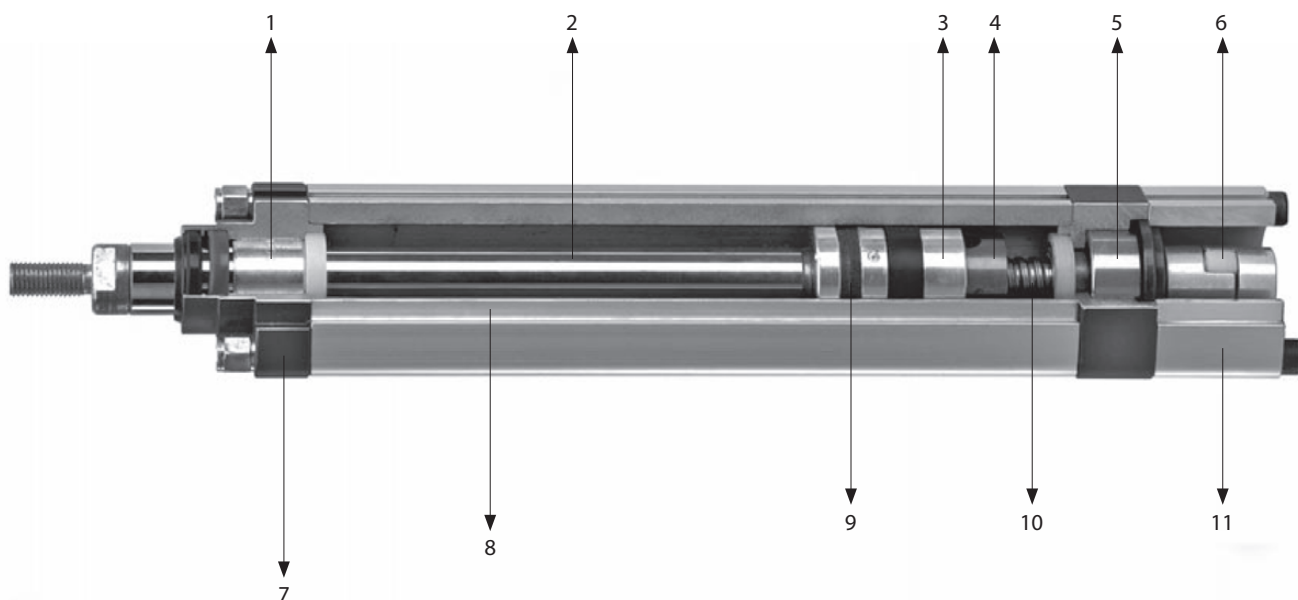

Materiali e Componenti	IT	Component Parts and Materials	GB	Komponenten und Materialien	DE
1 Boccola guida		1 Nose bearing		1 Kolbenstangen Lager	
2 Stelo cromato		2 Chrome plated rod		2 Verchromte Kolbenstange	
3 Pistone in Alluminio		3 Aluminium piston rod		3 Aluminium Kolben	
4 Chiocciola in Acciaio Temperato		4 Tempered steel Lead nut		4 Steigungsmutter aus gehärtetem Stahl	
5 Cuscinetto		5 Bearing		5 Lager	
6 Giunto		6 Screw support		6 Schraubenhalterung	
7 Campana		7 Front end cap		7 Vorderer Enddeckel	
8 Profilo estruso in Alluminio		8 Aluminium extruded profile		8 Extrudiertes Aluminium Profil	
9 Anello magnetico		9 Magnetic ring		9 Magnetring	
10 Vite in Acciaio Temperato		10 Tempered steel Lead screw		10 Steigungsschraube aus gehärtetem Stahl	
11 Testata in Alluminio		11 Aluminium rear end cap		11 Aluminium End-Deckel	

Matériaux et Composants	FR	Materiales y componentes	ES	Materiais e Componentes	PT
1 Douille de guidage		1 Cojinete guía		1 Bucha guia	
2 Tige chromée		2 Eje cromado		2 Haste cromada	
3 Piston en Aluminium		3 Pistón en aluminio		3 Pistão em alumínio	
4 Ecrou en Acier Trempé		4 Tuerca en acero templado		4 Porca em aço temperado	
5 Roulement		5 Cojinete		5 Rolamento	
6 Support vis		6 Articulación		6 Junta	
7 Nez avant		7 Campana		7 Cabeçote dianteiro	
8 Profil extrudé en Aluminium		8 Perfil extruido en aluminio		8 Perfil extrudado em alumínio	
9 Anneau magnétique		9 Anillo magnético		9 Anel magnético	
10 Vis en acier trempé		10 Tornillo en acero temperado		10 Parafuso em aço temperado	
11 Tête en Aluminium		11 Tapa en aluminio		11 Cabeçote em alumínio	

SERIE H & G - CILINDRI ELETTRICI SENZA MOTORE

ELECTRIC ACTUATORS WITHOUT MOTOR
 ELEKTRISCHE ZYLINDER OHNE MOTOR
 VERINS ELECTRIQUES SANS MOTEUR
 CILINDROS ELÉCTRICOS SIN MOTOR
 CILINDROS ELÉTRICOS SEM MOTOR

Serie H

Cilindri elettrici per motore in linea

Electric Actuator for In-line motor mount

Elektrischer Zylinder für Inline Motor

Actionneur électrique pour moteur en ligne

Cilindro eléctricos para motor en línea

Cilindros elétricos para motor em linha



Serie G

Cilindri elettrici per motore in parallelo

Electric Actuator for parallel motor mount

Elektrischer Zylinder für paralleler Motorbefestigung

Actionneur électrique pour moteur en parallèle

Cilindro eléctricos para motor en paralelo

Cilindros elétricos para motor em paralelo



SERIE H & G - CILINDRI ELETTRICI CON MOTORE

ELECTRIC ACTUATORS WITH MOTOR
 ELEKTRISCHE ZYLINDER MIT MOTOR
 VERINS ELECTRIQUES AVEC MOTEUR
 CILINDROS ELÉCTRICOS CON MOTOR
 CILINDROS ELÉTRICOS CON MOTOR

Serie H

Cilindri elettrici con motore in linea

Electric Actuator with In-line motor mount

Elektrischer Zylinder mit Inline Motor

Actionneur électrique avec moteur en ligne

Cilindro eléctricos con motor en línea

Cilindros elétricos com motor em linha



Serie G

Cilindri elettrici con motore in parallelo

Electric Actuator with parallel motor mount

Elektrischer Zylinder mit paralleler Motorbefestigung

Actionneur électrique avec moteur en parallèle

Cilindro eléctricos con motor en paralelo

Cilindros elétricos con motor em paralelo





Norma di Riferimento

Reference standard

Entspricht der Norm

Norme de référence

Normativa de referencia

Norma de referência

ISO
15552



Alesaggi

Bores

Durchmesser

Diamètres

Diámetros

Diâmetros

Ø 32 mm - Ø 40 mm
Ø 50 mm - Ø 63 mm



Temperature

Temperatures

Temperatur

Températures

Temperaturas

Temperaturas

- 20 °C
+ 100 °C



Sensori di fine corsa consigliati

Proximity sensors recommended

Näherungssensoren empfohlen

Capteurs de fin de course recommandés

Sensor de final de carrera aconsejado

Sensores de fim de curso aconselhados

DT

- 10 °C
+ 170 °C



Funzionamento antirotazione

Anti-rotation feature

Verdrehgesichert

Fonction anti rotation

Función antirrotación

Funcionamento anti-rotação



Corse standard fino a

Standard strokes up to

Standard Hub bis zu

Courses standard jusqu'à

Carrera estándar hasta

Cursos padrão de até

Ø 32
Max 800 mm.
Ø 40
Max 1000 mm.
Ø 50
Max 1200 mm.
Ø 63
Max 1400 mm.



Umidità

Humidity

Feuchtigkeit

Humidité

Humedad

Umidade

0 ÷ 90 %



Grado di protezione

Ingress Protection

Eindringenschutz

Indice de protection

Grado de protección

Grau de proteção

IP44



Tabella dei codici di ordinazione cilindri elettrici senza motore

Ordering codes electric actuator without motor

Bestellschlüssel elektrischer zylinder ohne motor

Code de commande actionneur électrique sans moteur

Tabla de codificación para pedidos cilindro eléctricos sin motor

Tabela de codificação para compra cilindros elétricos sem motor

SERIE	Ø	Corsa Stroke Hub Course Carrera Curso	Passo vite Screw Lead Steigung Pas de vis Paso tornillo Passo do fuso	Foro lubrificazione Lubrication hole Bohrung schmierung Trou de lubrification Agujero de lubricación Furo de lubrificação	Piastra dedicata Dedicated plate Platte anfordern Plaque dédiée Placa dedicada Placa dedicada
-------	---	--	--	--	--

H

0 3 2

0 1 0 0

0 5

1

- H** Cilindro motore in linea
In-line motor mount actuator
Zylinder Inline Motor
Actionneur moteur en ligne
Cilindro motor en línea
Cilindro com motor em linha

- 032**
- 040**
- 050**
- 063**

Ø	Corsa max Max stroke Hub max Course max Carrera max Curso máx	
	mm	mm
32	800	
40	1000	
50	1200	
63	1400	

- 05** -> 5 mm
- 10** -> 10 mm

- 1** Presente (NO Ø 32 mm)
Included (NO Ø 32 mm)
Inklusive (NO Ø 32 mm)
Inclus (NO Ø 32 mm)
Presente (NO Ø 32 mm)
Incluso (NO Ø 32 mm)
- 0** Assente (A richiesta)
Not included (On demand)
Nicht verfügbar (Auf Anfrage)
Non inclus (Sur demande)
Ausente (Bajo pedido)
Ausente (Sob demanda)

Standard (senza piastra)
Standard (without plate)
Standard (ohne Platte)
Standard (sans plaque)
Estandar (sin placa)
Padrão (sem placa)

- X1** Motore Mitsubishi®
Motor Mitsubishi®
Motor Mitsubishi®
Moteur Mitsubishi®
Motor Mitsubishi®
Motor Mitsubishi®
- X2** Motore Omron®
Motor Omron®
Motor Omron®
Moteur Omron®
Motor Omron®
Motor Omron®
- X3** Motore Rockwell®
Motor Rockwell®
Motor Rockwell®
Moteur Rockwell®
Motor Rockwell®
Motor Rockwell®

Ø mm	Corse - Strokes - Hub - Courses - Carreras - Cursos mm							
	100	150	200	250	300	350	400	500
32	■●		■●		■●			
40		■●		■●		■●		
50	■●		■●		■●			
63			■●		■●		■●	■●

H

CILINDRO ELETTRICO PER MOTORE IN LINEA

ELECTRIC ACTUATOR FOR IN-LINE MOTOR MOUNT
 ELEKTRISCHER ZYLINDER FÜR IN-LINE MOTOR
 ACTIONNEUR ÉLECTRIQUE POUR MOTEUR EN LIGNE
 CILINDRO ELÉCTRICOS PARA MOTOR EN LÍNEA
 CILINDROS ELÉTRICOS PARAMOTOR EM LINHA

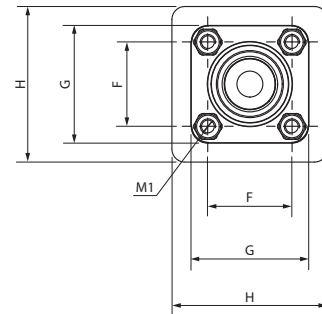
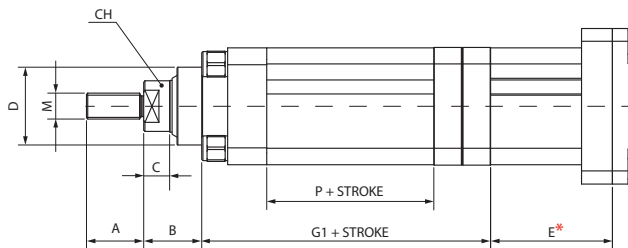

ØM	A	B	C	D	CH	E*	M	F	G	H	M1
32	22	22.5	10	Ø30 - h7	15	*	M10x1.25	32.5	45.5	60	M6x13
40	24	25	12	Ø35 - h7	17	*	M12x1.25	38	55	70	M6x13
50	32	25	12	Ø40 - h7	24	*	M16x1.5	46.5	63.5	86	M8x15
63	32	28	12	Ø45 - h7	30	*	M16x1.5	56.5	77	90	M8x16

*** Varia a seconda delle dimensioni del motore utilizzato**

** Varies depending on engine size motor used*

** Variiert je nach Größe des verwendete motors*

** Varie en fonction de la taille du moteur installé*

** Varía según el tamaño del motor usado*

** Varia dependendo do tamanho do motor usado*

VITE - SCREW - STEIGUNG - VIS - TORNILLO - FUSO		
Ø	P	G1
32	12x5	73.5
	12x10	73.5
40	16x5	88
	16x10	96
50	20x5	103.2
	20x10	112.2
63	25x5	119.1
	25x10	119.1

G



CILINDRO ELETTRICO PER MOTORE IN PARALLELO

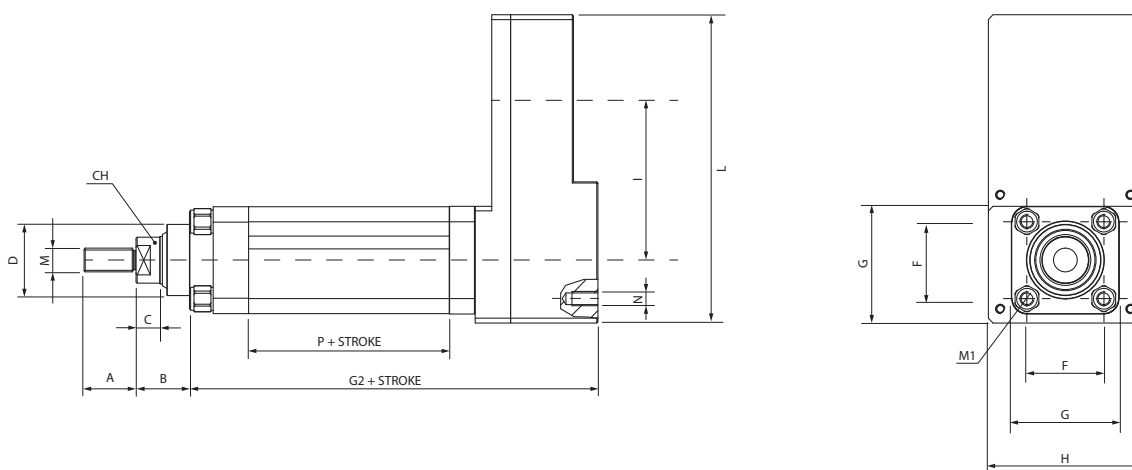











ELECTRIC ACTUATOR FOR PARALLEL MOTOR MOUNT
 ELEKTRISCHER ZYLINDER FÜR PARALLELER MOTORBEFESTIGUNG
 ACTIONNEUR ÉLECTRIQUE POUR MOTEUR EN PARALLÈLE
 CILINDRO ELÉCTRICOS PARA MOTOR EN PARALELO
 CILINDROS ELÉTRICOS PARA MOTOR EM PARALELO





ØM	A	B	C	D	CH	I	L	M1	F	G	H	N
32	22	22.5	10	Ø30 - h7	15	67.5	130	M10x1.25	32.5	45.5	65	M6x13
40	24	25	12	Ø35 - h7	17	67.5	134	M12x1.25	38	55	74.5	M6x13
50	32	25	12	Ø40 - h7	24	82.5	164	M16x1.5	46.5	63.5	90	M8x15
63	32	28	12	Ø45 - h7	30	90	186	M16x1.5	56.5	77	99	M8x16



VITE - SCREW - STEIGUNG - VIS - TORNILLO - FUSO		
Ø	P	G2
32	12x5	73.5
	12x10	73.5
40	16x5	88
	16x10	96
50	20x5	103.2
	20x10	112.2
63	25x5	119.1
	25x10	119.1













	AIGNEP®			SIEMENS®			CONTROL TECHNIQUES®		
	Modello Model Modell Modèle Modelo Modelo			Modello Model Modell Modèle Modelo Modelo			Modello Model Modell Modèle Modelo Modelo		
(mm) Dimensioni stelo Rod size Schaftgröße Taille tige Tamaño vástago Tamanho haste	A0	Ø 14	M5	1FK2103	Ø 14	-	MX401N2	Ø 14	M5
	B0	Ø 14	M5	1FK2103	Ø 14	-	MX401N2	Ø 14	M5
	C0	Ø 19	M5	1FK2104-5A	Ø 19	-	MX751N2	Ø 19	M5
	D0	Ø 19	M5	1FK2104-6A	Ø 19	-	MX751N2	Ø 19	M5
(mm) Flangia Flange Flansch Bride Brida Flange	A0	60x60		1FK2103	60x60		MX401N2	60x60	
	B0	60x60		1FK2103	60x60		MX401N2	60x60	
	C0	80x80		1FK2104-5A	80x80		MX751N2	80x80	
	D0	80x80		1FK2104-6A	80x80		MX751N2	80x80	
(mm) Coppia Torque Drehmoment Couple Par Torque	A0	1,27		1FK2103	1,27		MX401N2	1,27	
	B0	1,27		1FK2103	1,27		MX401N2	1,27	
	C0	2,40		1FK2104-5A	2,40		MX751N2	2,39	
	D0	3,20		1FK2104-6A	3,20		MX751N2	2,39	
(RPM) Velocità Speed Geschwindigkeit Vitesse Velocidad Velocidade	A0	3000		1FK2103	6000		MX401N2	3000	
	B0	3000		1FK2103	6000		MX401N2	3000	
	C0	3000		1FK2104-5A	3000		MX751N2	3000	
	D0	3000		1FK2104-6A	3000		MX751N2	3000	

Compatibilità Compatibility Kompatibilität Compatibilité Compatibilidad Compatibilidade	A0		1FK2103		MX401N2	
	B0		1FK2103		MX401N2	
	C0		1FK2104-5A		MX751N2	
	D0		1FK2104-6A		MX751N2	

 **100% Compatibile con cilindro Aignep**
 100% Compatible with Aignep cylinder
 100% Kompatibel mit Aignep Zylinder
 100% Compatible avec le cylindre Aignep
 100% Compatible con cilindro Aignep
 100% compatível com cilindro de Aignep

 **Compatibilità parziale, richiedere piastra dedicata**
 Partial compatibility, request dedicated plate
 Teilweise Kompatibilität, spezielle Platte anfordern
 Compatibilité partielle, demander plaque dédiée
 Compatibilidad parcial, requiere placa dedicada
 Compatibilidade parcial, solicitar placa dedicada

	MITSUBISHI®			OMRON®			ROCKWELL®		
	Modello Model Modell Modèle Modelo Modelo			Modello Model Modell Modèle Modelo Modelo			Modello Model Modell Modèle Modelo Modelo		
(mm) Dimensioni stelo Rod size Schaftgröße Taille tige Tamaño vástago Tamanho haste	HG-KN43	Ø 14	-	R88M-1M40030H	Ø 14	M5	TLY-A230T HJ62AA	Ø 14	M4
	HG-KN43	Ø 14	-	R88M-1M40030H	Ø 14	M5	TLY-A230T HJ62AA	Ø 14	M4
	HG-KN73	Ø 19	-	R88M-1M75030H	Ø 19	M5	TLY-A2530P HJ62AA	Ø 19,8	M5
	HG-KN73	Ø 19	-	R88M-1M75030H	Ø 19	M5	TLY-A310M HJ62AA	Ø 19,8	M5
(mm) Flangia Flange Flansch Bride Brida Flange	HG-KN43	60x60		R88M-1M40030H	60x60		TLY-A230T HJ62AA	60x60	
	HG-KN43	60x60		R88M-1M40030H	60x60		TLY-A230T HJ62AA	60x60	
	HG-KN73	80x80		R88M-1M75030H	80x80		TLY-A2530P HJ62AA	80x80	
	HG-KN73	80x80		R88M-1M75030H	80x80		TLY-A310M HJ62AA	86x86	
(mm) Coppia Torque Drehmoment Couple Par Torque	HG-KN43	1,30		R88M-1M40030H	1,27		TLY-A230T HJ62AA	1,30	
	HG-KN43	1,30		R88M-1M40030H	1,27		TLY-A230T HJ62AA	1,30	
	HG-KN73	2,40		R88M-1M75030H	2,39		TLY-A2530P HJ62AA	2,60	
	HG-KN73	2,40		R88M-1M75030H	239		TLY-A310M HJ62AA	3,61	
(RPM) Velocità Speed Geschwindigkeit Vitesse Velocidad Velocidade	HG-KN43	3000		R88M-1M40030H	3000		TLY-A230T HJ62AA	6000	
	HG-KN43	3000		R88M-1M40030H	3000		TLY-A230T HJ62AA	6000	
	HG-KN73	3000		R88M-1M75030H	3000		TLY-A2530P HJ62AA	5000	
	HG-KN73	3000		R88M-1M75030H	3000		TLY-A310M HJ62AA	4500	

Compatibilità Compatibility Kompatibilität Compatibilité Compatibilidad Compatibilidade	HG-KN43		R88M-1M40030H		TLY-A230T HJ62AA	
	HG-KN43		R88M-1M40030H		TLY-A230T HJ62AA	
	HG-KN73		R88M-1M75030H		TLY-A2530P HJ62AA	
	HG-KN73		R88M-1M75030H		TLY-A310M HJ62AA	

 **100% Compatibile con cilindro Aignep**
 100% Compatible with Aignep cylinder
 100% Kompatibel mit Aignep Zylinder
 100% Compatible avec le cylindre Aignep
 100% Compatible con cilindro Aignep
 100% compatível com cilindro de Aignep

 **Compatibilità parziale, richiedere piastra dedicata**
 Partial compatibility, request dedicated plate
 Teilweise Kompatibilität, spezielle Platte anfordern
 Compatibilité partielle, demander plaque dédiée
 Compatibilidad parcial, requiere placa dedicada
 Compatibilidade parcial, solicitar placa dedicada



Tabella dei codici di ordinazione cilindri elettrici con motore

Ordering codes electric actuator with motor

Bestellschlüssel elektrischer zylinder mit motor

Code de commande actionneur électrique avec moteur

Tabla de codificación para pedidos cilindro eléctricos con motor

Tabla de codificação para compra cilindros elétricos com motor

SERIE	∅	Corsa Stroke Hub Course Carrera Curso	Passo vite Screw Lead Steigung Pas de vis Paso tornillo Passo do fuso	Foro lubrificazione Lubrication hole Bohrung schmierung Trou de lubrification Agujero de lubricación Furo de lubrificação	Tipologia di motore Motor type Motor Typ Type de moteur Tipo de motor Tipologia de motor
-------	---	--	--	--	---

H **0 3 2** **0 1 0 0** **0 5** **1** **A** **0**

- **H** Cilindro motore in linea **032**
In-line motor mount actuator **040**
Zylinder Inline Motor **050**
Actionneur moteur en ligne **063**
Cilindro motor en linea
Cilindro com motor em linha
- **G** Cilindro motore in parallelo
Parallel motor mount actuator
Zylinder parallel motor an gebaut
Actionneur moteur en parallèle
Cilindro motor en paralelo
Cilindro com motor em paralelo

∅	Corsa max Max stroke Hub max Course max Carrera max Curso máx	
	mm	mm
32	800	
40	1000	
50	1200	
63	1400	

05 -> 5 mm
10 -> 10 mm

- 1** Presente (NO Ø 32 mm)
Included (NO Ø 32 mm)
Inklusive (NO Ø 32 mm)
Inclus (NO Ø 32 mm)
Presente (NO Ø 32 mm)
Incluso (NO Ø 32 mm)
- 0** Assente (A richiesta)
Not included (On demand)
Nicht verfügbar (Auf Anfrage)
Non inclus (Sur demande)
Ausente (Bajo pedido)
Ausente (Sob demanda)

- A** Tipologia A (Ø 32 mm)
Type A (Ø 32 mm)
Typ A (Ø 32 mm)
Type A (Ø 32 mm)
Tipo A (Ø 32 mm)
Tipologia A (Ø 32mm)
- B** Tipologia B (Ø 40 mm)
Type B (Ø 40 mm)
Typ B (Ø 40 mm)
Type B (Ø 40 mm)
Tipo B (Ø 40 mm)
Tipologia B (Ø 40mm)
- C** Tipologia C (Ø 50 mm)
Type C (Ø 50 mm)
Typ C (Ø 50 mm)
Type C (Ø 50 mm)
Tipo C (Ø 50 mm)
Tipologia C (Ø 50 mm)
- D** Tipologia D (Ø 63 mm)
Type D (Ø 63 mm)
Typ D (Ø 63 mm)
Type D (Ø 63 mm)
Tipo D (Ø 63 mm)
Tipologia D (Ø 63 mm)

- 0** Motore con encoder incrementale
Incremental encoder motor
Motor mit Inkremental-Drehgeber
Moteur codeur incrémental
Motor con encoder incremental
Motor com encoder incremental

A richiesta - On demand - Auf Anfrage - Sur demande - Bajo pedido - Sob demanda

- 1** Motore con encoder incrementale e freno
Incremental encoder motor with brake
Motor mit Inkremental-Drehgeber und Bremse
Moteur codeur incrémental avec frein
Motor con encoder incremental y freno
Motor com encoder incremental e freio
- 2** Motore con encoder assoluto
Absolute encoder motor
Absolute encoder motor
Moteur à codeur absolu
Motor con encoder absoluto
Motor com encoder absoluto
- 3** Motore con encoder assoluto e freno
Absolute encoder motor with brake
Absolute encoder motor with brake
Moteur codeur absolu avec frein
Motor con encoder absoluto y freno
Motor com encoder absoluto e freio

∅ mm	Corse - Strokes - Hub - Courses - Carreras - Cursos mm							
	100	150	200	250	300	350	400	500
32	■●		■●		■●			
40		■●		■●		■●		
50	■●		■●		■●			
63			■●		■●		■●	■●

H

CILINDRO ELETTRICO CON MOTORE IN LINEA

ELECTRIC ACTUATOR WITH IN-LINE MOTOR MOUNT
 ELEKTRISCHER ZYLINDER MIT IN-LINE MOTOR
 VERIN ELECTRIQUE AVEC MOTEUR EN LIGNE
 CILINDRO ELECTRICO CON MOTOR EN LINEA
 CILINDRO ELÉTRICO COM MOTOR EM LINHA

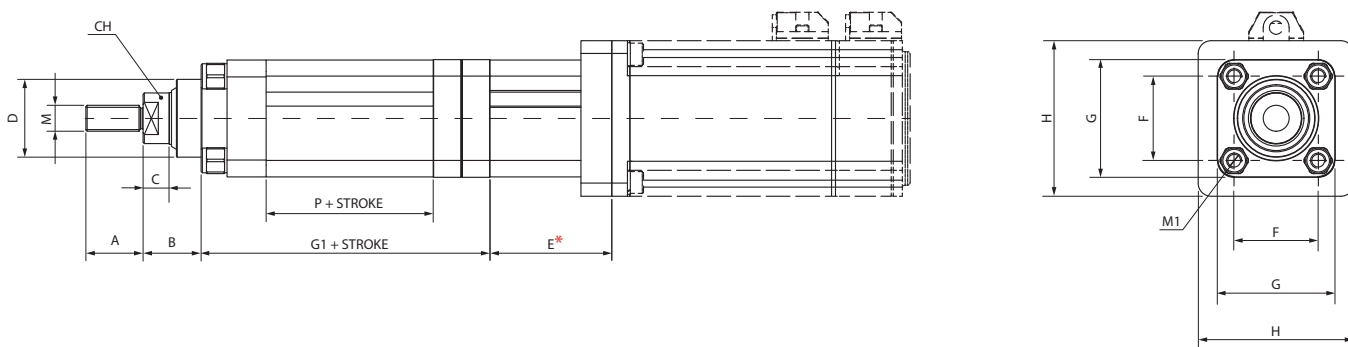

ØM	A	B	C	D	CH	E*	M	F	G	H	M1
32	22	22.5	10	Ø30 - h7	15	*	M10x1.25	32.5	45.5	60	M6x13
40	24	25	12	Ø35 - h7	17	*	M12x1.25	38	55	70	M6x13
50	32	25	12	Ø40 - h7	24	*	M16x1.5	46.5	63.5	86	M8x15
63	32	28	12	Ø45 - h7	30	*	M16x1.5	56.5	77	90	M8x16

* **Varia a seconda delle dimensioni del motore**
 * *Varies depending on engine size*
 * *Variiert je nach Größe des Motors*
 * *Varie en fonction de la taille du moteur*
 * *Varía según el tamaño del motor*
 * *Varia dependendo do tamanho do motor*

VITE - SCREW - STEIGUNG - VIS - TORNILLO - FUSO

Ø	P	G1
32	12x5	73.5
	12x10	73.5
40	16x5	88
	16x10	96
50	20x5	103.2
	20x10	112.2
63	25x5	119.1
	25x10	119.1

Ø	Codice motore Motor code Motor code Code moteur Código del motor Código do motor		Potenza Power Leistung Puissance Potencia Potência	Codificatore Encoder Encoder Codeur Encoder Encoder	Forza nominale Rated force Kraft Force nominale Fuerza nominal Força nominal	Velocità nominale Rated speed Geschwindigkeit Vitesse nominale Velocidad nominal Velocidade Nominal	Forza massima Peak force max Kraft Force maxi Fuerza máxima Força Máxima	Velocità massima Max speed Max Geschwindigkeit Vitesse maxi Velocidad máxima Velocidade Máxima
	mm	W	N	mm/s	N	mm/s		
32	12x5	A0	400	Incremental	1374	250	2100	556
	12x10	A0	400	Incremental	702	500	2100	1111
40	16x5	B0	400	Incremental	1355	250	3400	417
	16x10	B0	400	Incremental	697	500	3400	833
50	20x5	C0	750	Incremental	2514	250	6400	333
	20x10	C0	750	Incremental	1302	500	4850	667
63	25x5	D0	1000	Incremental	3307	250	11100	267
	25x10	D0	1000	Incremental	1728	500	11100	533

G

CILINDRO ELETTRICO CON MOTORE IN PARALLELO

ELECTRIC ACTUATOR WITH PARALLEL MOTOR MOUNT

ELEKTRISCHER ZYLINDER MIT PARALLEL ANGEBAUTEN MOTOR

VERIN ELECTRIQUE AVEC MOTEUR PARALLELE

CILINDRO ELECTRICO CON MOTOR EN PARALELO

CILINDRO ELÉTRICO COM MOTOR EM PARALELO

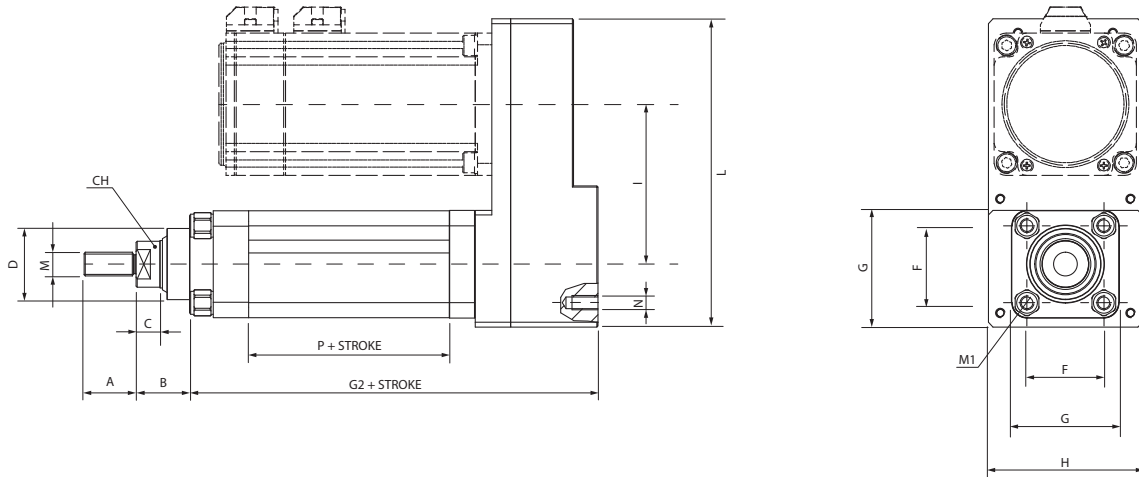

ØM	A	B	C	D	CH	I	L	M1	F	G	H	N
32	22	22.5	10	Ø30 - h7	15	67.5	130	M10x1.25	32.5	45.5	65	M6x13
40	24	25	12	Ø35 - h7	17	67.5	134	M12x1.25	38	55	74.5	M6x13
50	32	25	12	Ø40 - h7	24	82.5	164	M16x1.5	46.5	63.5	90	M8x15
63	32	28	12	Ø45 - h7	30	90	186	M16x1.5	56.5	77	99	M8x16

VITE - SCREW - STEIGUNG - VIS - TORNILLO - FUSO		
Ø	P	G2
32	12x5	73.5
	12x10	73.5
40	16x5	88
	16x10	96
50	20x5	103.2
	20x10	112.2
63	25x5	119.1
	25x10	119.1

Ø	Codice motore Motor code Motor code Code moteur Código del motor Código do motor		Potenza Power Leistung Puissance Potencia Potência	Codificatore Encoder Encoder Codeur Encoder Encoder	Forza nominale Rated force Kraft Force nominale Fuerza nominal Força nominal	Velocità nominale Rated speed Geschwindigkeit Vitesse nominale Velocidad nominal Velocidade Nominal	Forza massima Peak force max Kraft Force maxi Fuerza máxima Força Máxima	Velocità massima Max speed Max Geschwindigkeit Vitesse maxi Velocidad máxima Velocidade Máxima
	mm	W	N	mm/s	N	mm/s		
32	12x5	A0	400	Incremental	1237	250	2100	556
	12x10	A0	400	Incremental	632	500	2100	1111
40	16x5	B0	400	Incremental	1219	250	3400	417
	16x10	B0	400	Incremental	627	500	3400	833
50	20x5	C0	750	Incremental	2262	250	6400	333
	20x10	C0	750	Incremental	1172	500	6400	667
63	25x5	D0	1000	Incremental	2977	250	11100	267
	25x10	D0	1000	Incremental	1555	500	11100	533



Curve caratteristiche

Technical specifications

Technische Eigenschaften

Specifications Techniques

Curva de características

Curvas características

SERIE H/G - Ø 32 mm

SERIE H/G - Ø 40 mm

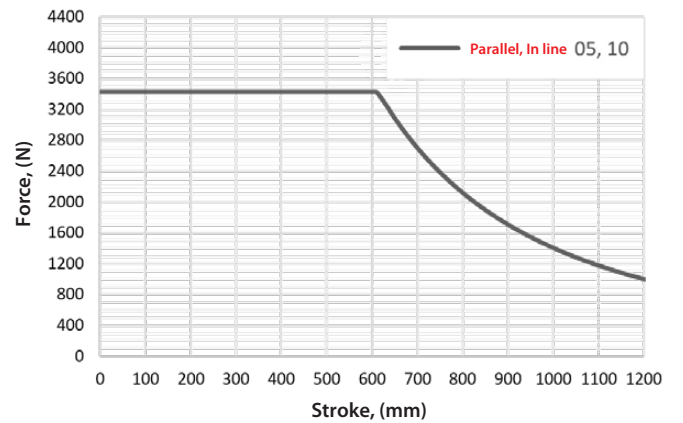
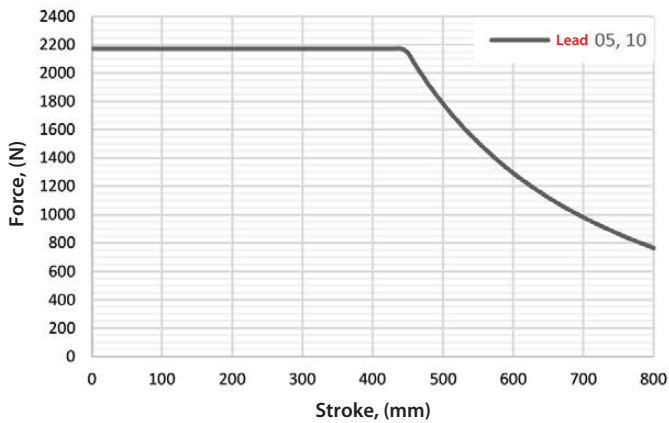
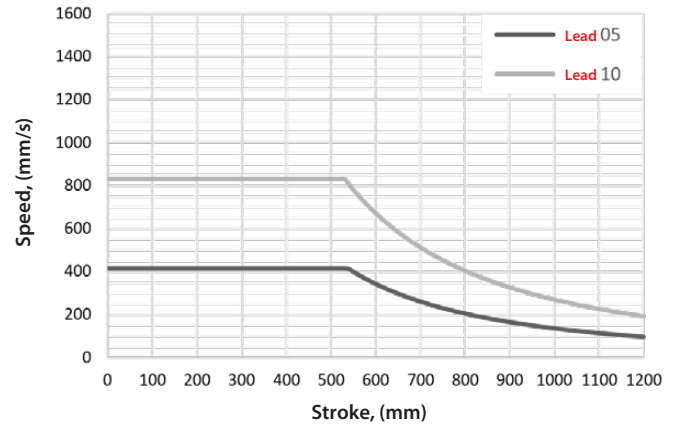
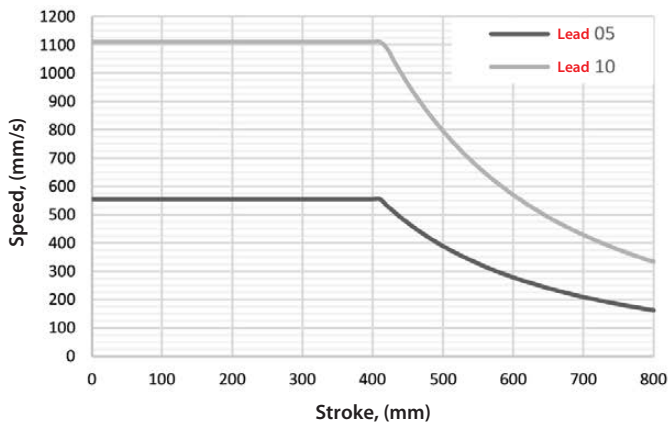
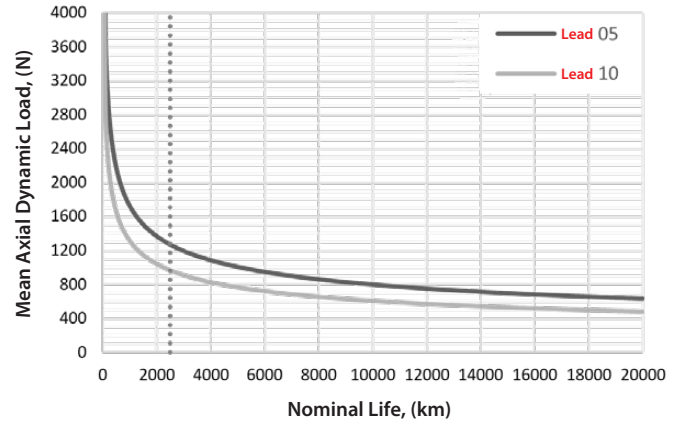
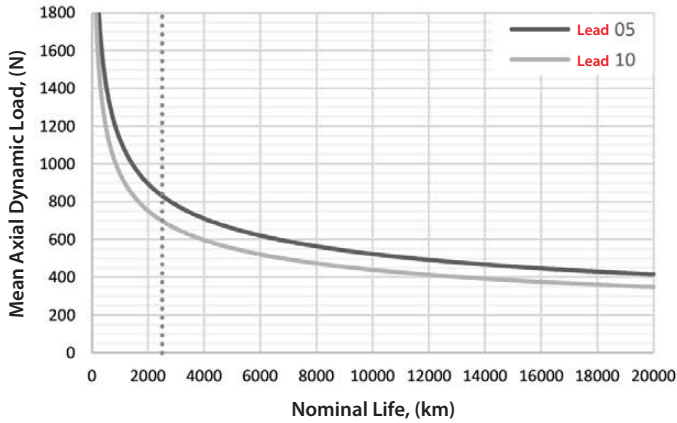



- Curve caratteristica
- Technical specifications
- Technische Eigenschaften
- Specifications Techniques
- Curva de características
- Curvas características

SERIE H/G - Ø 50 mm

SERIE H/G - Ø 63 mm

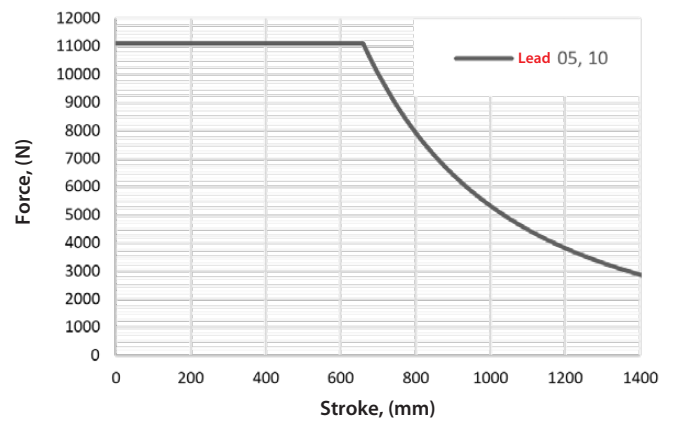
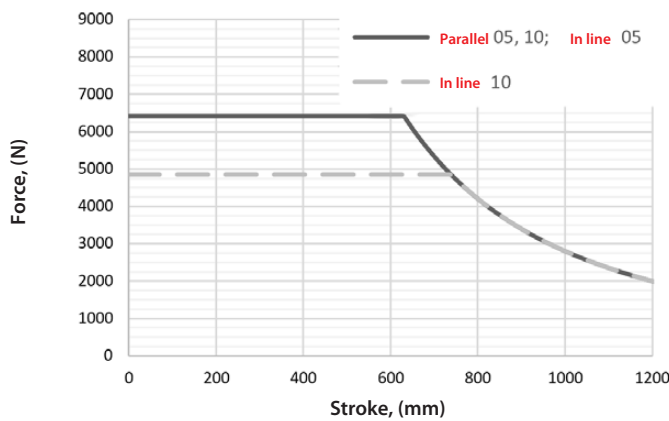
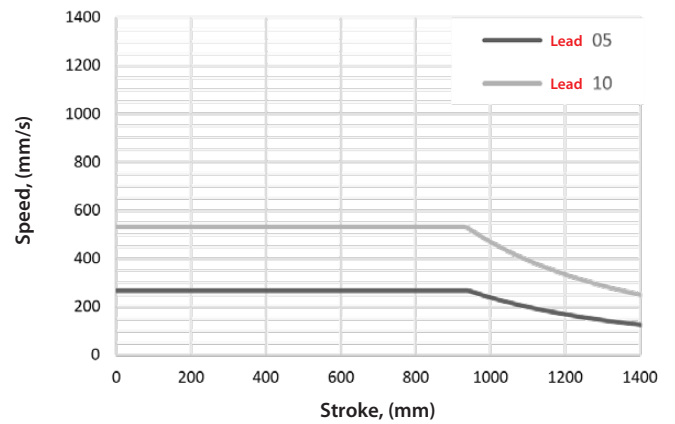
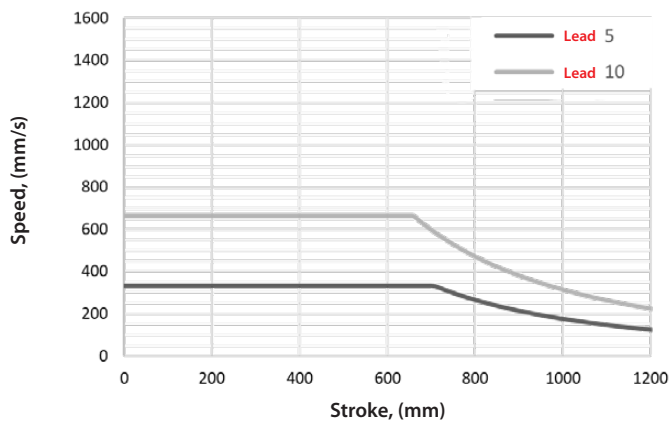
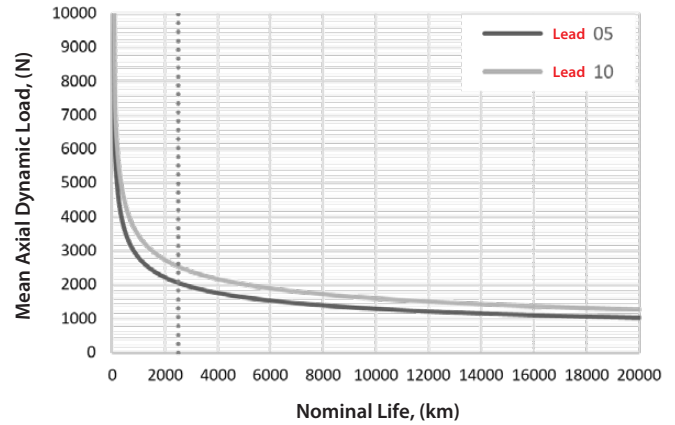
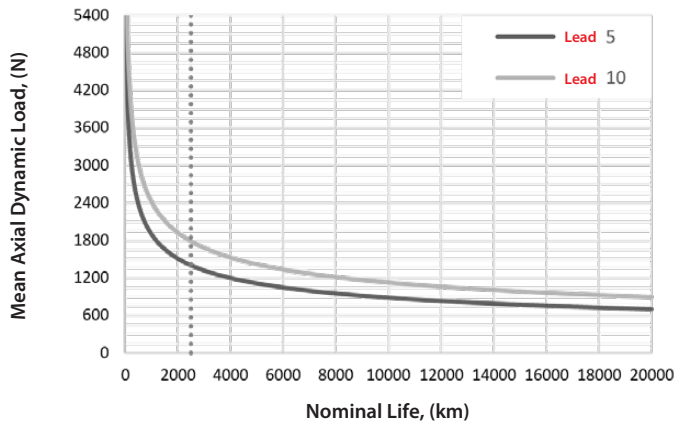

Ø		Ø 32 mm		Ø 40 mm		Ø 50 mm		Ø 63 mm		
Vite a sfera Ball screw Kugelumlaufspindel Vis à billes Tornillo esfera Fuso de Esfera	Passo Lead Steigung Pas Paso Passo	mm	5	10	5	10	5	10	5	10
	Ø Nominale Ø Nominal Ø Nominal Ø Nominal Ø Nominal	Ø mm	12	12	16	16	20	20	25	25
	Carico dinamico Dynamic load Dynamische last Charge dynamique Carga dinámica Carga dinámica	N	6600	4400	10104	6112	11154	11272	16383	15990
Meccanico Mechanical Mechanik Mécanique Mecánico Mecánico	Stelo Rod Kolbenstange Tige Eje Haste	Ø mm	20	20	25	25	30	30	35	35
	Terminale stelo Rod end Kolbenstangen Gewinde Extrémité de la tige Terminal eje Ponta da haste	mm	M10x1.25	M10x1.25	M12x1.25	M12x1.25	M16x1.5	M16x1.5	M16x1.5	M16x1.5
Forza (Max) Force (Max) Kraft (Max) Force (Max) Fuerza (Max) Força (Máx)	Forza in linea Line force Kraft Force en ligne Fuerza en línea Força em linha	N	2100	2100	3400	3400	6400	4850	11100	11100
	Coppia in linea Line torque Drehmoment Couple de ligne Par de linea Torque em linha	Nm	2.0	2.2	3.2	6.3	6.1	8.9	10.8	20.6
	Forza parallela Parallel force Parallel Kraft Force parallèle Fuerza paralela Força paralelo	N	2100	2100	3400	3400	6400	6400	11100	11100
	Coppia parallela Parallel torque Parallel Drehmoment Couple parallèle Par paralelo Torque paralelo	Nm	2.2	4.4	3.6	7.0	6.8	13.1	11.9	22.9
	Assiale dinamico Dynamic axial Dynamische axiale Axiale dynamique Axial dinámico Axial dinámico	at 2500 km (lifetime)	832	698	1273	970	1405	1789	2064	2538
Velocità Speed Geschwindigkeit Vitesse Velocidad Velocidade	Velocità (Max) Speed (Max) Geschwindigkeit (Max) Vitesse (Max) Velocidad (Max) Velocidade (Max)	rpm	6667	6667	5000	5000	4000	4000	3200	3200
		mm/s	556	1111	417	833	333	667	267	533
Accelerazione Acceleration Beschleunigung Accélération Aceleración Aceleração	Accelerazione(Max) Acceleration (Max) Geschwindigkeit (Max) Accélération (Max) Aceleración (Max) Aceleração (Máx)	m/s ²	3.2	6.4	3.2	6.4	3.2	6.4	3.2	6.4
Efficienza Efficiency Effizienz Rendement Eficiencia Eficiência	In linea In line Inline En ligne En línea Em linha	%	86	88	85	87	84	87	82	86
	In parallelo In parallel Parallel En parallèle En paralelo Em Paralelo	%	77	79	76	79	75	78	74	77

SET YOUR ELECTRIC ACTUATOR PART. 2/2

DATI INDISPENSABILI - ESSENTIAL DATA - UNENTBEHRLICHE DATEN - DONNÉES INDISPENSABLES - DATOS INDISPENSABLE - DADOS ESSENCIAIS

Carico massimo in spinta o trazione *1: Max push/pull load: Maximale Schub-/Zuglast: Charge maximale de poussée/traction: Carga máxima en empuje o tracción: Carga máxima em avanço/recuo:	Kg: _____	Tempo di un ciclo completo (avanti/dietro): Cycle time required: Zykluszeit: Temps de cycle requis: Tiempo de un ciclo completo (adelante/atrás): Tempo de um ciclo completo (avanço/recuo):	_____ sec
Posizione lavoro (orizzontale/verticale/angolo): Working angle: Arbeitsbereich: Angle de travail: Posición de trabajo (horizontal / vertical / ángulo): Posição de trabalho (horizontal/vertical/ângulo):	0°/90°: _____	Necessità di freno a stelo fermo: Idle brake required: Leerlaufbremse erforderlich: Frein à vide requis: Requiere un freno con el vástago detenido: Necessidade de freio com haste parada:	Yes / No: _____
Solo Posizionamento o spinta fondo corsa *2: Positioning / pushing at end of stroke: Positionierung bis Hubende: Positionnement/poussée en fin de course: Posicionamiento / empuje final de carrera: Posicionar/empurrar no final do curso:	Yes / No: _____	Necessità di motorizzazione: Motor required: Mit Motor: Moteur requis: Necesita motorización: Necessidade de motorização:	Yes / No: _____
Corsa totale utile del sistema: Working stroke: Arbeitshub: Course de travail: Carrera de trabajo: Curso útil da sistema:	_____ mm	Necessità di driver di potenza: Driver required: Treiber erforderlich: Pilote requis: Necesita driver de potencia: Necessidade de driver de potência:	Yes / No: _____
Corsa al carico massimo: Stroke at max load: Hub bei Maximallast: Course à charge maxi: Carrera a carga máxima: Curso com carga máxima:	_____ mm	*1: Indicare il peso reale del gruppo da movimentare più la forza durante o alla fine della corsa Please specify the load to move, plus the force required during or at the end of the stroke Bitte geben sie die zu bewegendende last und die kraft an die während oder am ende des hubs erforderlich ist Veuillez spécifier la charge à déplacer, ainsi que la force requise pendant ou à la fin de la course Indicar el peso real del grupo a mover más la fuerza durante o al final del recorrido Indicar a carga a ser movimentada mais a força requerida durante ou no fim de curso	
Velocità di lavoro al carico massimo *3: Speed required on Max load: Erforderliche Geschwindigkeit bei Maximallast: Vitesse requise sur charge max: Velocidad de trabajo a carga máxima: Velocidade de trabalho com carga máxima:	_____ mm/sec	*2: NO: la capacità di continuare a spingere anche se il cilindro non raggiunge la quota preimpostata NO: The cylinder will keep on working till set position is reached Wenn nichts gewählt wird: Der Zylinder fährt bis die eingestellte Position erreicht ist NON: le vérin continuera de fonctionner jusqu'à ce que la position définie soit atteinte NO: el cilindro seguirá funcionando hasta alcanzar la posición establecida NÃO: o cilindro continuará a trabalhar até atingir a posição pré-ajustada	
Velocità massima richiesta *3: Max speed required: Erforderliche Geschwindigkeit: Vitesse requise max: Velocidad máxima requerida: Velocidade máxima requerida:	_____ mm/sec	*3: Se questo dato non è disponibile, è necessario specificare il tempo per un ciclo completo If unknown please specify cycle time Wenn unbekannt, bitte Zykluszeit angeben Si pas indiqué, veuillez spécifier le temps de cycle Si estos datos no están disponibles, se debe especificar el tiempo del ciclo completo: Se este dado for desconhecido, especificar um tempo para um ciclo completo	

DATI FACOLTATIVI - OPTIONAL DATA - FREIWILLIGE ANGABEN - DONNÉES FACULTATIVES - DATOS OPCIONALES - DADOS OPCIONAIS

Numero di cicli completi al minuto: Cycles per minute: Zyklen pro Minute: Nombre de cycles par minute: Número de ciclos completos por minuto: Ciclos por minuto:	_____	
Numero di ore lavorate al giorno: Working hours per day: Nutzungszeit pro Tag: Nombre d'heures de travail par jour: Número de horas trabajadas al día: Horas de trabalho por dia:	_____	
Precisione di posizionamento necessaria: Positioning precision: Genauigkeit bei der Positionierung: Précision de positionnement: Precisión de posicionamiento: Precisão de posicionamento necessária:	mm/100	_____
Motorizzazione in linea o parallela: In Line or Parallel motor mount: Inline oder Parallell Motor montiert: Montage moteur en ligne ou parallèle: Montaje del motor en línea o paralelo: Motorização em linha ou paralela:	L: In-Line P: Parallel	_____