

### Regolatori di Portata

Flow Regulator Valves  
Durchflussregler  
Raccords Régleurs de Débit  
Reguladores de Caudal  
Reguladoras de Vazão Séries



Pag. 11.4

### Regolatori di Portata Serie 8900

Flow Regulators Valves 8900 Series  
Durchflussregler Serie 8900  
Régleurs de Débit Série 8900  
Reguladores de Caudal Serie 8900  
Reguladoras de Vazão Série 8900



Pag. 11.19

### Regolatori di Portata in Linea

In Line Adjustable Restrictor Valves  
Durchflussregler für Leitungseinbau  
Régleurs de débit en Ligne  
Reguladores de Flujo en Linea  
Reguladoras de Vazão em Linha



Pag. 11.29

### Regolatori di Pressione in Linea

In Line Pressure Regulator Valves  
Druckregler für Leitungseinbau  
Régleurs de Pression en Ligne  
Reguladores de Presión en Línea  
Regulador de Pressão em Linha



Pag. 11.35

### Regolatori di Flusso Unidirezionali e Bidirezionali

Uni-directional and Bi-directional Flow Regulator  
Durchflussregler mit Rückschlag und Bi-Direktional  
Régleurs de Débit Uni-directionnel et Bi-directionnel  
Reguladores de Flujo Unidireccionales y Bidireccional  
Reguladoras de Vazão Unidireccional e Bi-Direccional



Pag. 11.39 - 11.41

### Elementi Logici

Logic Elements  
Logik Elemente  
Selecteurs de Circuit  
Elementos Lógicos  
Elementos Lógicos



Pag. 11.43

### Valvole a Scarico Rapido

Quick Exhaust Valve  
Schnellentlüftungsventile  
Vanne à Purge Rapide  
Válvula de Escape Rápido  
Válvula Escape Rápido



Pag. 11.46

### Valvole a Corsoio

Slide Valve  
Handschieventile  
Clapet coulissant  
Válvulas de Corredera  
Válvulas Deslizantes



Pag. 11.49

### Valvole Unidirezionali o di non ritorno

Unidirectional valves or non return valves  
Rückschlagventile  
Clapet anti-retour  
Válvulas unidireccionales o antiretorno  
Válvulas unidireccionais ou anti-retorno



Pag. 11.52

### Valvole di Blocco

Block Valves  
Stoppventil  
Stop-Vérin  
Válvulas de Bloqueo  
Válvulas de Bloqueio



Pag. 11.61

### Moltiplicatore di pressione

Pressure Boosters  
Druckübersetzer  
Multiplificateurs de pression  
Multiplicadores de presión  
Multiplicadores de pressão



Pag. 11.69

### Valvola Coassiale di Intercettazione

Coaxial valve  
Pneumatisches axialventil  
Vanne d'arrêt  
Válvula de cierre  
Válvula de intercepção



Pag. 11.78

**COMPONENTI A FUNZIONE**

*FUNCTIONAL COMPONENTS*

*FUNKTIONSKOMPONENTEN*

*COMPOSANTS À FONCTIONS*

*COMPONENTES CON FUNCIÓN*

*COMPONENTES FUNCIONAIS*

**Serie Function**



FUNCTION

In automazione pneumatica, numerose funzioni devono essere espletate da componenti progettati per un uso specifico. I raccordi a funzioni pneumatiche Aignep sono concepiti per soddisfare queste funzioni. Sono realizzate in ottone, in tecnopolimero, in acciaio inox 316L ed in alluminio. Compatti, di semplice utilizzo, i raccordi a funzione Aignep, rispondono alle esigenze più spinte nell'automazione pneumatica moderna. Sono disponibili: regolatori di flusso, di pressione, valvole unidirezionali, intercettori di blocco, scarichi rapidi, valvole a corsoio, elementi logici.

### Principali vantaggi

- Compattezza e precisione delle nostre funzioni pneumatiche
- Perdite di carico contenute
- Ergonomici e facilmente manovrabili
- Ripetibilità della funzione
- Differenti materiali in base all'esigenza applicativa
- Silicon Free

### Applicazioni

- Automazione pneumatica
- Automotive process
- Food & Beverage
- Intercettazione aria compressa e fluidi
- Vuoto

Les raccords à fonction Aignep ont été conçus pour répondre à des besoins spécifiques dans les applications automatisées.

Grande variété de matériaux (laiton, acier inoxydable, technopolymère, aluminium). Ils répondent aux utilisations les plus difficiles : régulateurs de débit, régulateurs de pression, clapets anti retour, stop vérin, clapet anti retour piloté, vannes vannes à purge rapide, éléments à fonctions logiques, vanne coulissante, etc.

### Principaux avantages

- Compact et grande précision de réglage
- Chutes de pression limitées
- Facile à utiliser
- Maintien du réglage
- Différents matériaux
- Sans silicone

### Applications

- Automatisme pneumatiques
- Process automobile
- Agro alimentaire
- Vide

The function fittings of Aignep have been designed to suit a specific use.

With a large variety of materials (brass, stainless steel, technopolymer, aluminium) they respond to the most extreme demand of pneumatic: flow controls, pressure regulators, unidirectional valves, block valves, check valves, quick exhaust valves, logic elements, slide valves, etc.

### Main advantages

- Compact and Sharp in Pneumatic
- Limited Pressure Drop
- Easy to handle
- Function Repeatability
- Different Materials
- Silicon Free

### Applications

- Pneumatic automation
- Automotive process
- Food & Beverage
- Fluidtechnology
- Vacuum

En automatización neumática, muchas funciones deben ser realizadas por componentes que están diseñados para un uso específico. Los racores a funciones neumáticas Aignep están diseñados para cumplir estas funciones. Están hechas en latón, Tecnopolímero, acero inoxidable AISI 316L y aluminio. Compactas, fáciles de usar, los racores a funciones Aignep, cumplen con los requisitos más exigentes en la automatización industrial moderna. Disponibles: reguladores de flujo, de presión, válvulas unidireccionales, interceptores de bloqueo, escapes rápidos, válvulas de corredera, elementos lógicos.

### Principales ventajas

- La compacidad y la precisión de nuestras funciones neumáticas
- Pérdidas de carga contenidas
- Ergonómicas y fáciles de utilizar
- La repetitividad de las funciones
- Diferentes materiales en base a la exigencia aplicativa
- Libres de silicona

### Aplicaciones

- Automatización neumática
- Procesos de automoción
- Alimentos y bebidas
- Interceptación aire comprimido y fluidos
- Vacío

Die Funktionsverschraubungen von Aignep wurden für bestimmte Anwendungen entwickelt.

Mit einer großen Vielfalt von Materialien (Messing, Edelstahl, Technopolymer, Aluminium) antworten sie auf die meisten extremen Anforderungen in der Pneumatik: Durchflusskontrolle, Druckregler, Einwegventile, Absperrventile, Rückschlagventile, Schnellentlüftungsventile, Logikelemente, Schieber, etc.

### Hauptvorteile

- Kompakt und präzise pneumatische Funktionen
- Begrenzter Druckabfall
- Einfach zu bedienen
- Funktion Wiederholbarkeit
- Verschiedene Materialien
- Silikonfrei

### Anwendungen

- Pneumatische Automation
- Automobil-Industrie
- Lebensmittel & Getränke
- Fluidtechnik
- Vakuum

As conexões de função da Aignep foram desenvolvidas para atender às mais específicas aplicações.

Com uma grande variedade de materiais (latão, aço-inoxidável, tecnopolímero, alumínio) esta linha de produtos atendem às mais extremas necessidades da automação pneumática: controle de vazão, reguladores de pressão, válvulas de retenção, válvulas unidirecionais, válvulas de escape rápido, elementos lógicos, válvulas deslizantes, etc.

### Principais vantagens

- Alta precisão funcional e design compacto
- Queda de pressão reduzida
- Facilidade de manuseio
- Repetibilidade precisa
- Fabricada em diferentes materiais
- Livre de Silicone

### Aplicações

- Automação pneumática
- Processos automotivos
- Alimentos & Bebidas
- Fluidos
- Vácuo

## REGOLATORI DI PORTATA ORIENTABILI

ORIENTING FLOW REGULATOR  
 DURCHFLUSSREGLER (DREHBAR)  
 RÉGLEURS DE DÉBIT ORIENTABLES  
 REGULADORES DE CAUDAL ORIENTABLES  
 REGULADORAS DE VAZÃO ORIENTÁVEL



### CARATTERISTICHE TECNICHE

TECHNICAL CHARACTERISTICS  
 TECHNISCHE ANGABEN  
 CARACTÉRISTIQUES TECHNIQUES  
 CARACTERÍSTICAS TÉCNICAS  
 CARACTERÍSTICAS TÉCNICAS



### Norma di Riferimento

Reference standard

Entspricht der Norm

Norme de référence

Normativa de referencia

Norma de referência

1907/2006

REACH ✓

2011/65/CE

RoHS ✓

PED

2014/68/UE

SILICON

FREE



### Pressioni

Pressures

Druckbereich

Pressions

Presiones

Pressões

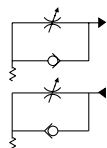

**1 bar** (0.1 MPa)

**10 bar** (1 MPa)

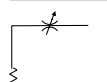

**0.1 bar** (0.01 MPa)

**10 bar** (1 MPa)



### Temperature

Temperatures

Temperatur

Températures

Temperaturas

Temperaturas

**- 20 °C**

**+ 80 °C**



### Fluidi compatibili

Aria compressa

Fluids

Compressed air

Geeignete Medien

Druckluft

Fluides compatibles

Air comprimé

Fluidos compatibles

Aire comprimido

Fluidos compatíveis

Ar comprimido



### Tubi di Collegamento

Tubi in materiale plastico:

PA6, PA11, PA12, Polietilene, \*Poliuretano, PTFE, FEP.

\*Utilizzo da 90 a 98 Shore, per la massima prestazione è consigliato 98 Shore A.

IT

### Connection Tubes

Plastic tubes:

PA6, PA11, PA12, Polyethylene, \*Polyurethane, PTFE, FEP.

\*Use from 90 to 98 Shore, for maximum performance is recommended 98 Shore A.

GB

### Geeignete Rohre

Kunststoffrohre:

PA6, PA11, PA 12, Polyethylene, \*Polyurethan, PTFE, FEP.

\*Verwenden Sie 90 bis 98 Shore, für maximale Leistung wird 98 Shore A empfohlen.

DE

### Tubes Conseillés

Tubes plastiques:

PA6, PA11, PA12, Polyéthylène, \*Polyuréthane, PTFE, FEP.

\*Utilisation de 90 à 98 Shore, pour une performance maximale recommandée 98 Shore A.

FR

### Tubos de Conexión

Tubos en material plástico:

PA6, PA11, PA 12, Polietileno, \*Poliuretano, PTFE, FEP.

\*Uso de 90 a 98 Shore, para un máximo rendimiento se recomienda 98 Shore A.

ES

### Tubos de Conexão

Tubos em material plástico:

PA6, PA11, PA12, Polietileno, \*Poliuretano, PTFE, FEP.

\*Uso de 90 a 98 Shore, para o desempenho máximo é recomendado 98 Shore A.

PT



**UNIDIREZIONALE PER CILINDRO**

UNI-DIRECTIONAL FOR CYLINDER

DROSSELUNG FÜR ZYLINDER (ABLUFT)

UNIDIRECTIONNEL À L'ÉCHAPPEMENT

UNIDIRECCIONAL PARA CILINDRO

UNIDIRECCIONAL PARA CILINDRO

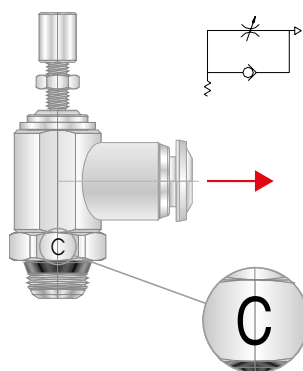

**CODE:**

50901 - 55900 - 56900 - 57901

50905 - 55905 - 56935 - 57905

55902

55906



**UNIDIREZIONALE PER VAVOLA**

UNI-DIRECTIONAL FOR VALVE

DROSSELUNG FÜR VENTILE (ZULUFT)

UNIDIRECTIONNEL À L'ADMISSION

UNIDIRECCIONAL PARA VÁLVULA

UNIDIRECCIONAL PARA VÁLVULA

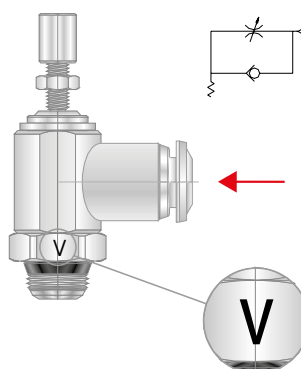

**CODE:**

50910 - 55910 - 56910 - 57910

50915 - 55915 - 56945 - 57915

55912

55916



**BIDIREZIONALE**

BI-DIRECTIONAL

BI-DIREKTIONAL (OHNE RÜCKSCHLAG)

BI-DIRECTIONNEL

BIDIRECCIONAL

BI-DIRECCIONAL

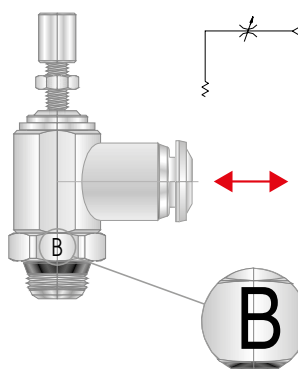

**CODE:**

50920 - 55920 - 56920 - 57920

50925 - 55925 - 56955 - 57925

55922

55926

LEGENDA  
KEY  
LEGENDE  
LEGENDE  
LEYENDA  
LEGENDA



**Regolazione a cacciavite** - Screwdriver regulation - Einstellbar mit schraubenzieher  
A vis noyée - Regulación a destornillador - Regulagem por parafuso



**Regolazione manuale** - Manual regulation - Einstellbar von hand  
Réglage manuel - Regulación manual - Regulagem manual



<b>Filettatura</b> Gas conica "UNIVERSAL SHORT". Gas cilindrica conforme ISO 228 Classe A. Metrica conforme ISO R/262.	<b>IT</b>	<b>Threads</b> "UNIVERSAL SHORT" Tapered thread. Parallel gas in conformity with ISO 228 Class A. Metric in conformity with ISO R/262.	<b>GB</b>	<b>Gewindearten</b> Konisches Gewinde "UNIVERSAL SHORT". Zylindrisches Gewinde nach Norm ISO 228 Classe A. Metrisches Gewinde nach Norm ISO R/262.	<b>DE</b>
<b>Filetages</b> Filetage conique "UNIVERSAL SHORT". Filetage cylindrique conforme: ISO 228 Classe A. Filetage métrique conforme: ISO R/262.	<b>FR</b>	<b>Roscas</b> Gas cónica "UNIVERSAL SHORT". Gas cilindrica conforme ISO 228 Clase A. Métrica conforme ISO R/262.	<b>ES</b>	<b>Roscas</b> Gas cônica "UNIVERSAL SHORT". Gas paralela conforme ISO 228 Classe A. Métrica conforme ISO R/262.	<b>PT</b>



**UNIVERSAL SHORT**

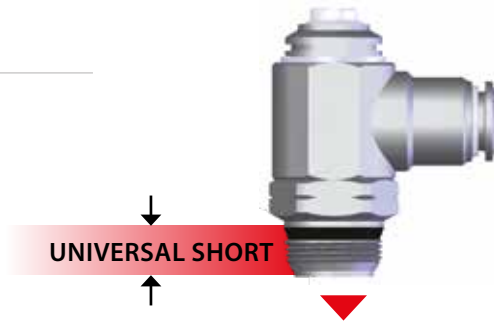

<b>NPT</b> <b>NPTF</b>	Conica Tapered Konisch Conique Cónica Cônica	<b>ISO 7</b> <b>BSPP</b>	Cilindrica Paralell Zylindrisch Cylindrique Cilíndrica Paralela	<b>ISO 7</b> <b>BSPT</b> <b>PT</b>	Conica Tapered Konisch Conique Cónica Cônica	<b>ISO 228</b> <b>BSP</b> <b>PF</b>	Cilindrica Paralell Zylindrisch Cylindrique Cilíndrica Paralela
---------------------------	-------------------------------------------------------------	-----------------------------	--------------------------------------------------------------------------------	------------------------------------------	-------------------------------------------------------------	-------------------------------------------	--------------------------------------------------------------------------------

<b>"UNIVERSAL SHORT"</b> La filettatura conica "UNIVERSAL SHORT" è progettata per soddisfare le seguenti caratteristiche: • ridurre la lunghezza d'ingombro; • ridurre la chiave rispetto ad alcuni raccordi con filettature cilindriche; • consentire l'accoppiamento con diversi standard di filettature femmina sia coniche che cilindriche.	<b>IT</b>	<b>"UNIVERSAL SHORT"</b> The "UNIVERSAL SHORT" taper thread has been designed to offer the following advantages to the users: • reduced overall length; • smaller hex dimensions compared to the parallel threads; • to allow the assembly with different female threads both taper as well as parallel.	<b>GB</b>	<b>"UNIVERSAL SHORT"</b> Das konische Gewinde "UNIVERSAL SHORT" ist so konzipiert, dass folgende Vorteile erzielt werden: • Reduzierung der Länge des Gewindes-kürzere Montagezeit; • Reduzierung der Schlüsselweite im Vergleich von Verschraubungen mit zylindrischen Gewinden-geringerer Lochabstand; • Ermöglicht den Einsatz in verschiedene Gewindearten, sowie in konische- und zylindrische Innengewinde.	<b>DE</b>
-------------------------------------------------------------------------------------------------------------------------------------------------------------------------------------------------------------------------------------------------------------------------------------------------------------------------------------------------------------	-----------	----------------------------------------------------------------------------------------------------------------------------------------------------------------------------------------------------------------------------------------------------------------------------------------------------------------------	-----------	-------------------------------------------------------------------------------------------------------------------------------------------------------------------------------------------------------------------------------------------------------------------------------------------------------------------------------------------------------------------------------------------------------------------------------	-----------

<b>"UNIVERSAL SHORT"</b> Le filetage conique "UNIVERSAL SHORT" a été conçu pour satisfaire les exigences suivantes: • réduire la longueur d'encroisement; • réduire les dimensions hexagonales par rapport au filetage cylindrique; • permettre le montage avec divers taraudages standards soit coniques soit cylindriques.	<b>FR</b>	<b>"UNIVERSAL SHORT"</b> La rosca cónica "UNIVERSAL SHORT" ha sido proyectada para satisfacer las siguientes características: • reducir la longitud; • reducir la llave respecto a algunos racores con rosca cilíndrica; • permitir el acoplamiento con diferentes standard de rosca hembra sean cónicas o cilíndricas.	<b>ES</b>	<b>"UNIVERSAL SHORT"</b> A rosca cônica "UNIVERSAL SHORT" é projetada para satisfazer às seguintes características: • reduzir o comprimento da conexão; • reduzir o dimensional com relação às roscas paralelas; • permitir o acoplamento da conexão a diferentes tipos de rosca fêmea, sejam elas cônicas ou paralelas.	<b>PT</b>
------------------------------------------------------------------------------------------------------------------------------------------------------------------------------------------------------------------------------------------------------------------------------------------------------------------------------------------	-----------	-------------------------------------------------------------------------------------------------------------------------------------------------------------------------------------------------------------------------------------------------------------------------------------------------------------------------------------	-----------	--------------------------------------------------------------------------------------------------------------------------------------------------------------------------------------------------------------------------------------------------------------------------------------------------------------------------------------	-----------



**Inclinate**  
Inclined  
Geneigt  
Incliné  
Inclinada  
Inclinadas



**Concave**  
Concave  
Konkav  
Concave  
Côncava  
Côncavas



**Convexe**  
Convex  
Konvex  
Convexe  
Convexa  
Convexas

Consentire una completa tenuta anche su superfici non perfettamente piane, concave, convesse o inclinate, con diversi smussi o raggi.	<b>IT</b>	To ensure the right tightening also with surfaces not perfectly flat, without spot-facing, concave convex and with different kinds of chamfers or radius.	<b>GB</b>	Eine vollständige Abdichtung ist auch auf unebenen Flächen, wie geneigt, konkav oder konvex und mit unterschiedlichen Radien oder Fasen gewährleistet.	<b>DE</b>
---------------------------------------------------------------------------------------------------------------------------------------	-----------	-----------------------------------------------------------------------------------------------------------------------------------------------------------	-----------	--------------------------------------------------------------------------------------------------------------------------------------------------------	-----------

Pour permettre une parfaite étanchéité même sur des surfaces non planes, concaves, convexas ou inclinées et avec différents chanfreins ou rayons.	<b>FR</b>	Consentir una completa estanqueidad incluso en superficies no perfectamente planas, côncavas, convexas o inclinadas, con diferentes ángulos o radios.	<b>ES</b>	Permite um aperto correto em superfícies não perfeitamente planas, côncavas, convexas ou inclinadas, com diferentes chanfros ou raios.	<b>PT</b>
---------------------------------------------------------------------------------------------------------------------------------------------------	-----------	-------------------------------------------------------------------------------------------------------------------------------------------------------	-----------	----------------------------------------------------------------------------------------------------------------------------------------	-----------

## 50901

**REGOLATORE UNIDIREZIONALE ORIENTABILE PER CILINDRO "UNIVERSAL SHORT"**  
 ORIENTING FLOW REGULATOR FOR CYLINDER "UNIVERSAL SHORT"  
 DURCHFLOSSREGLER ABLUFTDROSSELUNG (DREHBAR) "UNIVERSAL SHORT"  
 RÉGLEUR DE DÉBIT À L'ÉCHAPPEMENT FILETAGE (ORIENTABLE) "UNIVERSAL SHORT"  
 REGULADOR UNIDIRECCIONAL ORIENTABLE PARA CILINDRO "UNIVERSAL SHORT"  
 REGULADORA UNIDIRECCIONAL ORIENTÁVEL PARA CILINDRO ROSCA "UNIVERSAL SHORT"

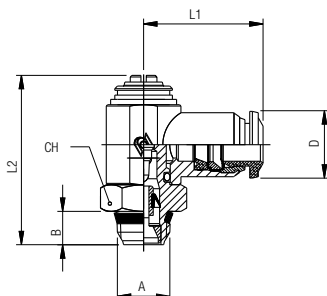
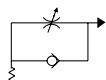

Code	Tube	A	B	L1	L2	CH	D	Pack.
50901 00 001	3	M5	4	19	29.5	8	10	10
50901 00 002	4	M5	4	19	29.5	8	10	10
50901 00 003	4	1/8	5.5	21	31	14	10	10
50901 00 004	5	M5	4	20	29.5	8	12.5	10
50901 00 005	5	1/8	5.5	21.5	31	14	12.5	10
50901 00 006	5	1/4	7	24.5	36.5	17	12.5	10
50901 00 007	6	M5	4	20.5	29.5	8	12.5	10
50901 00 008	6	1/8	5.5	22.5	31	14	12.5	10
50901 00 009	6	1/4	7	25	36.5	17	12.5	10
50901 00 010	8	1/8	5.5	24	31	14	14	10
50901 00 011	8	1/4	7	26	36.5	17	14	10
50901 00 016	8	3/8	7.5	28.5	42.5	20	14	10
50901 00 017	10	1/4	7	28.5	36.5	17	17	10
50901 00 012	10	3/8	7.5	30.5	42.5	20	17	10
50901 00 013	12	3/8	7.5	32.5	42.5	20	21.5	10
50901 00 014	12	1/2	9	35	47	24	21.5	10
50901 00 015	14	1/2	9	35.5	47	24	21.5	10

## 50910

**REGOLATORE UNIDIREZIONALE ORIENTABILE PER VALVOLA "UNIVERSAL SHORT"**  
 ORIENTING FLOW REGULATOR FOR VALVE "UNIVERSAL SHORT"  
 DURCHFLOSSREGLER ZULUFTDROSSELUNG (DREHBAR) "UNIVERSAL SHORT"  
 RÉGLEUR DE DÉBIT À L'ADMISSION FILETAGE (ORIENTABLE) "UNIVERSAL SHORT"  
 REGULADOR UNIDIRECCIONAL ORIENTABLE PARA VÁLVULA "UNIVERSAL SHORT"  
 REGULADORA UNIDIRECCIONAL ORIENTÁVEL PARA VÁLVULA ROSCA "UNIVERSAL SHORT"

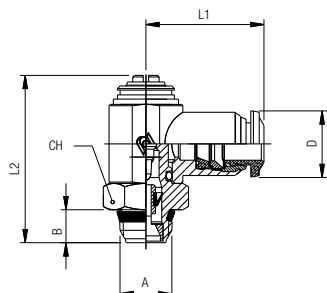
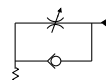

Code	Tube	A	B	L1	L2	CH	D	Pack.
50910 00 001	3	M5	4	19	29.5	8	10	10
50910 00 002	4	M5	4	19	29.5	8	10	10
50910 00 003	4	1/8	5.5	21	31	14	10	10
50910 00 004	5	M5	4	20	29.5	8	12.5	10
50910 00 005	5	1/8	5.5	21.5	31	14	12.5	10
50910 00 006	5	1/4	7	24.5	36.5	17	12.5	10
50910 00 007	6	M5	4	20.5	29.5	8	12.5	10
50910 00 008	6	1/8	5.5	22.5	31	14	12.5	10
50910 00 009	6	1/4	7	25	36.5	17	12.5	10
50910 00 010	8	1/8	5.5	24	31	14	14	10
50910 00 011	8	1/4	7	26	36.5	17	14	10
50910 00 016	8	3/8	7.5	28.5	42.5	20	14	10
50910 00 017	10	1/4	7	28.5	36.5	17	17	10
50910 00 012	10	3/8	7.5	30.5	42.5	20	17	10
50910 00 013	12	3/8	7.5	32.5	42.5	20	21.5	10
50910 00 014	12	1/2	9	35	47	24	21.5	10
50910 00 015	14	1/2	9	35.5	47	24	21.5	10

## 50920

**REGOLATORE BIDIREZIONALE ORIENTABILE "UNIVERSAL SHORT"**  
 ORIENTING BI-DIRECTIONAL FLOW REGULATOR "UNIVERSAL SHORT"  
 DURCHFLOSSREGLER BI-DIREKTIONAL (DREHBAR) "UNIVERSAL SHORT"  
 RÉGLEUR DE DÉBIT BI-DIRECTIONNEL FILETAGE (ORIENTABLE) "UNIVERSAL SHORT"  
 REGULADOR BIDIRECCIONAL ORIENTABLE "UNIVERSAL SHORT"  
 REGULADORA BI-DIRECCIONAL ORIENTÁVEL ROSCA "UNIVERSAL SHORT"

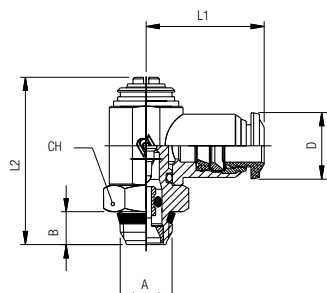

Code	Tube	A	B	L1	L2	CH	D	Pack.
50920 00 001	3	M5	4	19	29.5	8	10	10
50920 00 002	4	M5	4	19	29.5	8	10	10
50920 00 003	4	1/8	5.5	21	31	14	10	10
50920 00 004	5	M5	4	20	29.5	8	12.5	10
50920 00 005	5	1/8	5.5	21.5	31	14	12.5	10
50920 00 006	5	1/4	7	24.5	36.5	17	12.5	10
50920 00 007	6	M5	4	20.5	29.5	8	12.5	10
50920 00 008	6	1/8	5.5	22.5	31	14	12.5	10
50920 00 009	6	1/4	7	25	36.5	17	12.5	10
50920 00 010	8	1/8	5.5	24	31	14	14	10
50920 00 011	8	1/4	7	26	36.5	17	14	10
50920 00 016	8	3/8	7.5	28.5	42.5	20	14	10
50920 00 017	10	1/4	7	28.5	36.5	17	17	10
50920 00 012	10	3/8	7.5	30.5	42.5	20	17	10
50920 00 013	12	3/8	7.5	32.5	42.5	20	21.5	10
50920 00 014	12	1/2	9	35	47	24	21.5	10
50920 00 015	14	1/2	9	35.5	47	24	21.5	10

## 50905

### REGOLATORE UNIDIREZIONALE ORIENTABILE PER CILINDRO "UNIVERSAL SHORT"

ORIENTING FLOW REGULATOR FOR CYLINDER "UNIVERSAL SHORT"

DURCHFLOSSREGLER ABLUFTDROSSELUNG (DREHBAR) "UNIVERSAL SHORT"

RÉGLEUR DE DÉBIT À L'ÉCHAPPEMENT FILETAGE (ORIENTABLE) "UNIVERSAL SHORT"

REGULADOR UNIDIRECCIONAL ORIENTABLE PARA CILINDRO "UNIVERSAL SHORT"

REGULADORA UNIDIRECCIONAL ORIENTÁVEL PARA CILINDRO ROSCA "UNIVERSAL SHORT"

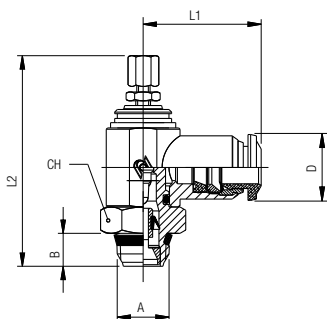
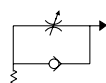

Code	Tube	A	B	L1	L2 min	L2 max	CH	D	Pack.
50905 00 001	3	M5	4	19	39.5	43.5	8	10	10
50905 00 002	4	M5	4	19	39.5	43.5	8	10	10
50905 00 003	4	1/8	5.5	21	44	49	14	10	10
50905 00 004	5	M5	4	20	39.5	43.5	8	12.5	10
50905 00 005	5	1/8	5.5	21.5	44	49	14	12.5	10
50905 00 006	5	1/4	7	24.5	48.5	55	17	12.5	10
50905 00 007	6	M5	4	20.5	39.5	43.5	8	12.5	10
50905 00 008	6	1/8	5.5	22.5	44	49	14	12.5	10
50905 00 009	6	1/4	7	25	48.5	55	17	12.5	10
50905 00 010	8	1/8	5.5	24	44	49	14	14	10
50905 00 011	8	1/4	7	26	48.5	55	17	14	10
50905 00 016	8	3/8	7.5	28.5	56	65	20	14	10
50905 00 017	10	1/4	7	28.5	48.5	55	17	17	10
50905 00 012	10	3/8	7.5	30.5	56	65	20	17	10
50905 00 013	12	3/8	7.5	32.5	56	65	20	21.5	10
50905 00 014	12	1/2	9	35	62	69	24	21.5	10
50905 00 015	14	1/2	9	35.5	62	69	24	21.5	10

## 50915

### REGOLATORE UNIDIREZIONALE ORIENTABILE PER VALVOLA "UNIVERSAL SHORT"

ORIENTING FLOW REGULATOR FOR VALVE "UNIVERSAL SHORT"

DURCHFLOSSREGLER ZULUFTDROSSELUNG (DREHBAR) "UNIVERSAL SHORT"

RÉGLEUR DE DÉBIT À L'ADMISSION FILETAGE (ORIENTABLE) "UNIVERSAL SHORT"

REGULADOR UNIDIRECCIONAL ORIENTABLE PARA VÁLVULA "UNIVERSAL SHORT"

REGULADORA UNIDIRECCIONAL ORIENTÁVEL PARA VÁLVULA ROSCA "UNIVERSAL SHORT"

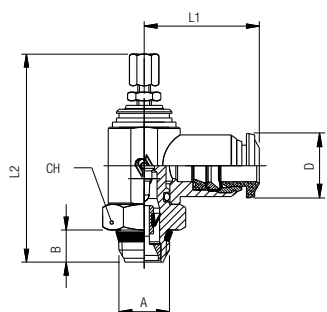
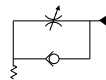

Code	Tube	A	B	L1	L2 min	L2 max	CH	D	Pack.
50915 00 001	3	M5	4	19	39.5	43.5	8	10	10
50915 00 002	4	M5	4	19	39.5	43.5	8	10	10
50915 00 003	4	1/8	5.5	21	44	49	14	10	10
50915 00 004	5	M5	4	20	39.5	43.5	8	12.5	10
50915 00 005	5	1/8	5.5	21.5	44	49	14	12.5	10
50915 00 006	5	1/4	7	24.5	48.5	55	17	12.5	10
50915 00 007	6	M5	4	20.5	39.5	43.5	8	12.5	10
50915 00 008	6	1/8	5.5	22.5	44	49	14	12.5	10
50915 00 009	6	1/4	7	25	48.5	55	17	12.5	10
50915 00 010	8	1/8	5.5	24	44	49	14	14	10
50915 00 011	8	1/4	7	26	48.5	55	17	14	10
50915 00 016	8	3/8	7.5	28.5	56	65	20	14	10
50915 00 017	10	1/4	7	28.5	48.5	55	17	17	10
50915 00 012	10	3/8	7.5	30.5	56	65	20	17	10
50915 00 013	12	3/8	7.5	32.5	56	65	20	21.5	10
50915 00 014	12	1/2	9	35	62	69	24	21.5	10
50915 00 015	14	1/2	9	35.5	62	69	24	21.5	10

## 50925

### REGOLATORE BIDIREZIONALE ORIENTABILE "UNIVERSAL SHORT"

ORIENTING BI-DIRECTIONAL FLOW REGULATOR "UNIVERSAL SHORT"

DURCHFLOSSREGLER BI-DIREKTIONAL (DREHBAR) "UNIVERSAL SHORT"

RÉGLEUR DE DÉBIT BI-DIRECTIONNEL FILETAGE (ORIENTABLE) "UNIVERSAL SHORT"

REGULADOR BIDIRECCIONAL ORIENTABLE "UNIVERSAL SHORT"

REGULADORA BI-DIRECCIONAL ORIENTÁVEL ROSCA "UNIVERSAL SHORT"

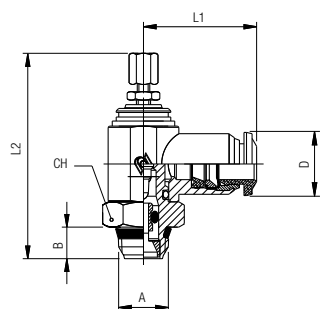

Code	Tube	A	B	L1	L2 min	L2 max	CH	D	Pack.
50925 00 001	3	M5	4	19	39.5	43.5	8	10	10
50925 00 002	4	M5	4	19	39.5	43.5	8	10	10
50925 00 003	4	1/8	5.5	21	44	49	14	10	10
50925 00 004	5	M5	4	20	39.5	43.5	8	12.5	10
50925 00 005	5	1/8	5.5	21.5	44	49	14	12.5	10
50925 00 006	5	1/4	7	24.5	48.5	55	17	12.5	10
50925 00 007	6	M5	4	20.5	39.5	43.5	8	12.5	10
50925 00 008	6	1/8	5.5	22.5	44	49	14	12.5	10
50925 00 009	6	1/4	7	25	48.5	55	17	12.5	10
50925 00 010	8	1/8	5.5	24	44	49	14	14	10
50925 00 011	8	1/4	7	26	48.5	55	17	14	10
50925 00 016	8	3/8	7.5	28.5	56	65	20	14	10
50925 00 017	10	1/4	7	28.5	48.5	55	17	17	10
50925 00 012	10	3/8	7.5	30.5	56	65	20	17	10
50925 00 013	12	3/8	7.5	32.5	56	65	20	21.5	10
50925 00 014	12	1/2	9	35	62	69	24	21.5	10
50925 00 015	14	1/2	9	35.5	62	69	24	21.5	10

## 55900

**REGOLATORE UNIDIREZIONALE ORIENTABILE PER CILINDRO "UNIVERSAL SHORT"**  
 ORIENTING FLOW REGULATOR FOR CYLINDER "UNIVERSAL SHORT"  
 DURCHFLOSSREGLER ABLUFTDROSSELUNG (DREHBAR) "UNIVERSAL SHORT"  
 RÉGLEUR DE DÉBIT À L'ÉCHAPPEMENT FILETAGE (ORIENTABLE) "UNIVERSAL SHORT"  
 REGULADOR UNIDIRECCIONAL ORIENTABLE PARA CILINDRO "UNIVERSAL SHORT"  
 REGULADORA UNIDIRECCIONAL ORIENTÁVEL PARA CILINDRO ROSCA "UNIVERSAL SHORT"

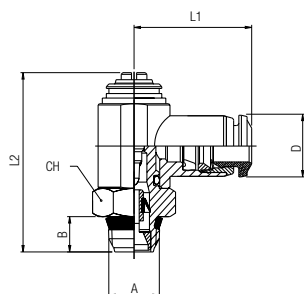
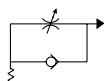

Code	Tube	A	B	L1	L2	CH	D	Pack.
55900 00 002	4	M5	5.5	19.5	29.5	8	10	10
55900 00 003	4	1/8	5.5	21.5	31	14	10	10
55900 00 004	5	M5	5.5	20.5	29.5	8	12.5	10
55900 00 005	5	1/8	5.5	22.5	31	14	12.5	10
55900 00 006	5	1/4	7	25	36.5	17	12.5	10
55900 00 007	6	M5	5.5	21	29.5	8	12.5	10
55900 00 008	6	1/8	5.5	23	31	14	12.5	10
55900 00 009	6	1/4	7	25.5	36.5	17	12.5	10
55900 00 010	8	1/8	5.5	23.5	31	14	14	10
55900 00 011	8	1/4	7	26	36.5	17	14	10
55900 00 012	8	3/8	8.5	27.5	42.5	20	14	10
55900 00 013	10	3/8	8.5	30.5	42.5	20	17	10
55900 00 014	12	3/8	8.5	32.5	42.5	20	21.5	10
55900 00 015	12	1/2	10	35	47	24	21.5	10

## 55910

**REGOLATORE UNIDIREZIONALE ORIENTABILE PER VALVOLA "UNIVERSAL SHORT"**  
 ORIENTING FLOW REGULATOR FOR VALVE "UNIVERSAL SHORT"  
 DURCHFLOSSREGLER ZULUFTDROSSELUNG (DREHBAR) "UNIVERSAL SHORT"  
 RÉGLEUR DE DÉBIT À L'ADMISSION FILETAGE (ORIENTABLE) "UNIVERSAL SHORT"  
 REGULADOR UNIDIRECCIONAL ORIENTABLE PARA VÁLVULA "UNIVERSAL SHORT"  
 REGULADORA UNIDIRECCIONAL ORIENTÁVEL PARA VÁLVULA ROSCA "UNIVERSAL SHORT"

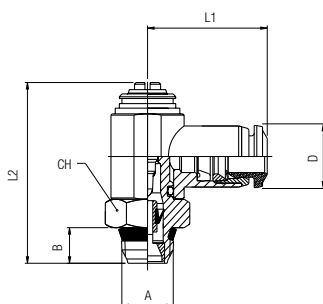
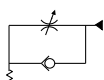

Code	Tube	A	B	L1	L2	CH	D	Pack.
55910 00 002	4	M5	4	19.5	29.5	8	10	10
55910 00 003	4	1/8	5.5	21.5	31	14	10	10
55910 00 004	5	M5	4	20.5	29.5	8	12.5	10
55910 00 005	5	1/8	5.5	22.5	31	14	12.5	10
55910 00 006	5	1/4	7	25	36.5	17	12.5	10
55910 00 007	6	M5	4	21	29.5	8	12.5	10
55910 00 008	6	1/8	5.5	23	31	14	12.5	10
55910 00 009	6	1/4	7	25.5	36.5	17	12.5	10
55910 00 010	8	1/8	5.5	23.5	31	14	14	10
55910 00 011	8	1/4	7	26	36.5	17	14	10
55910 00 012	8	3/8	8.5	27.5	42.5	20	14	10
55910 00 013	10	3/8	8.5	30.5	42.5	20	17	10
55910 00 014	12	3/8	8.5	32.5	42.5	20	21.5	10
55910 00 015	12	1/2	10	35	47	24	21.5	10

## 55920

**REGOLATORE BIDIREZIONALE ORIENTABILE "UNIVERSAL SHORT"**  
 ORIENTING BI-DIRECTIONAL FLOW REGULATOR "UNIVERSAL SHORT"  
 DURCHFLOSSREGLER BI-DIREKTIONAL (DREHBAR) "UNIVERSAL SHORT"  
 RÉGLEUR DE DÉBIT BI-DIRECTIONNEL FILETAGE (ORIENTABLE) "UNIVERSAL SHORT"  
 REGULADOR BIDIRECCIONAL ORIENTABLE "UNIVERSAL SHORT"  
 REGULADORA BI-DIRECCIONAL ORIENTÁVEL ROSCA "UNIVERSAL SHORT"

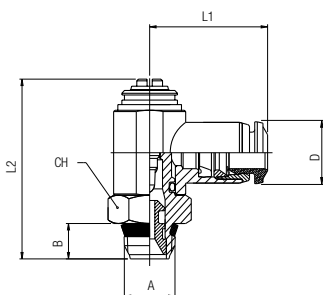

Code	Tube	A	B	L1	L2	CH	D	Pack.
55920 00 002	4	M5	4	19.5	29.5	8	10	10
55920 00 003	4	1/8	5.5	21.5	31	14	10	10
55920 00 004	5	M5	4	20.5	29.5	8	12.5	10
55920 00 005	5	1/8	5.5	22.5	31	14	12.5	10
55920 00 006	5	1/4	7	25	36.5	17	12.5	10
55920 00 007	6	M5	4	21	29.5	8	12.5	10
55920 00 008	6	1/8	5.5	23	31	14	12.5	10
55920 00 009	6	1/4	7	25.5	36.5	17	12.5	10
55920 00 010	8	1/8	5.5	23.5	31	14	14	10
55920 00 011	8	1/4	7	26	36.5	17	14	10
55920 00 012	8	3/8	8.5	27.5	42.5	20	14	10
55920 00 013	10	3/8	8.5	30.5	42.5	20	17	10
55920 00 014	12	3/8	8.5	32.5	42.5	20	21.5	10
55920 00 015	12	1/2	10	35	47	24	21.5	10

## 55905

### REGOLATORE UNIDIREZIONALE ORIENTABILE PER CILINDRO "UNIVERSAL SHORT"

ORIENTING FLOW REGULATOR FOR CYLINDER "UNIVERSAL SHORT"

DURCHFLOSSREGLER ABLUFTDROSSELUNG (DREHBAR) "UNIVERSAL SHORT"

RÉGLEUR DE DÉBIT À L'ÉCHAPPEMENT FILETAGE (ORIENTABLE) "UNIVERSAL SHORT"

REGULADOR UNIDIRECCIONAL ORIENTABLE PARA CILINDRO "UNIVERSAL SHORT"

REGULADORA UNIDIRECCIONAL ORIENTÁVEL PARA CILINDRO ROSCA "UNIVERSAL SHORT"

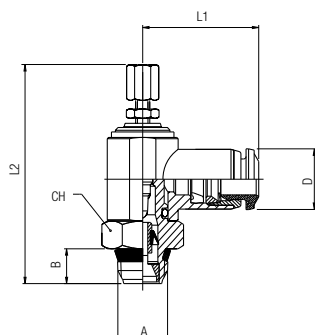
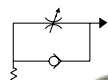

Code	Tube	A	B	L1	L2 min	L2 max	CH	D	Pack.
55905 00 002	4	M5	4	19.5	39.5	43.5	8	10	10
55905 00 003	4	1/8	5.5	21.5	44	49	14	10	10
55905 00 004	5	M5	4	20.5	39.5	43.5	8	12.5	10
55905 00 005	5	1/8	5.5	22.5	44	49	14	12.5	10
55905 00 006	5	1/4	7	25	48.5	55	17	12.5	10
55905 00 007	6	M5	4	21	39.5	43.5	8	12.5	10
55905 00 008	6	1/8	5.5	23	44	49	14	12.5	10
55905 00 009	6	1/4	7	25.5	48.5	55	17	12.5	10
55905 00 010	8	1/8	5.5	23.5	44	49	14	14	10
55905 00 011	8	1/4	7	26	48.5	55	17	14	10
55905 00 012	8	3/8	8.5	27.5	56	65	20	14	10
55905 00 013	10	3/8	8.5	30.5	56	65	20	17	10
55905 00 014	12	3/8	8.5	32.5	56	65	20	21.5	10
55905 00 015	12	1/2	10	35	62	69	24	21.5	10

## 55915

### REGOLATORE UNIDIREZIONALE ORIENTABILE PER VALVOLA "UNIVERSAL SHORT"

ORIENTING FLOW REGULATOR FOR VALVE "UNIVERSAL SHORT"

DURCHFLOSSREGLER ZULUFTDROSSELUNG (DREHBAR) "UNIVERSAL SHORT"

RÉGLEUR DE DÉBIT À L'ADMISSION FILETAGE (ORIENTABLE) "UNIVERSAL SHORT"

REGULADOR UNIDIRECCIONAL ORIENTABLE PARA VÁLVULA "UNIVERSAL SHORT"

REGULADORA UNIDIRECCIONAL ORIENTÁVEL PARA VÁLVULA ROSCA "UNIVERSAL SHORT"

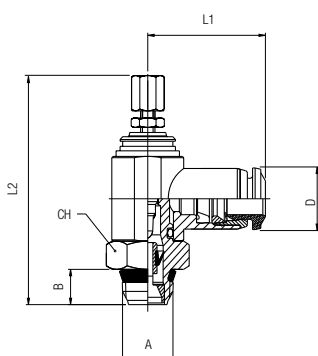
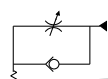

Code	Tube	A	B	L1	L2 min	L2 max	CH	D	Pack.
55915 00 002	4	M5	4	19.5	39.5	43.5	8	10	10
55915 00 003	4	1/8	5.5	21.5	44	49	14	10	10
55915 00 004	5	M5	4	20.5	39.5	43.5	8	12.5	10
55915 00 005	5	1/8	5.5	22.5	44	49	14	12.5	10
55915 00 006	5	1/4	7	25	48.5	55	17	12.5	10
55915 00 007	6	M5	4	21	39.5	43.5	8	12.5	10
55915 00 008	6	1/8	5.5	23	44	49	14	12.5	10
55915 00 009	6	1/4	7	25.5	48.5	55	17	12.5	10
55915 00 010	8	1/8	5.5	23.5	44	49	14	14	10
55915 00 011	8	1/4	7	26	48.5	55	17	14	10
55915 00 012	8	3/8	8.5	27.5	56	65	20	14	10
55915 00 013	10	3/8	8.5	30.5	56	65	20	17	10
55915 00 014	12	3/8	8.5	32.5	56	65	20	21.5	10
55915 00 015	12	1/2	10	35	62	69	24	21.5	10

## 55925

### REGOLATORE BIDIREZIONALE ORIENTABILE "UNIVERSAL SHORT"

ORIENTING BI-DIRECTIONAL FLOW REGULATOR "UNIVERSAL SHORT"

DURCHFLOSSREGLER BI-DIREKTIONAL (DREHBAR) "UNIVERSAL SHORT"

RÉGLEUR DE DÉBIT BI-DIRECTIONNEL FILETAGE (ORIENTABLE) "UNIVERSAL SHORT"

REGULADOR BIDIRECCIONAL ORIENTABLE "UNIVERSAL SHORT"

REGULADORA BI-DIRECCIONAL ORIENTÁVEL ROSCA "UNIVERSAL SHORT"

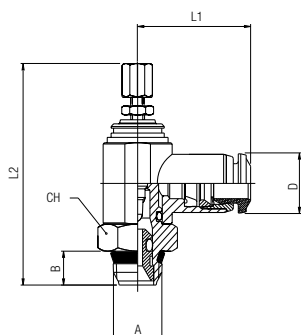

Code	Tube	A	B	L1	L2 min	L2 max	CH	D	Pack.
55925 00 002	4	M5	4	19.5	39.5	43.5	8	10	10
55925 00 003	4	1/8	5.5	21.5	44	49	14	10	10
55925 00 004	5	M5	4	20.5	39.5	43.5	8	12.5	10
55925 00 005	5	1/8	5.5	22.5	44	49	14	12.5	10
55925 00 006	5	1/4	7	25	48.5	55	17	12.5	10
55925 00 007	6	M5	4	21	39.5	43.5	8	12.5	10
55925 00 008	6	1/8	5.5	23	44	49	14	12.5	10
55925 00 009	6	1/4	7	25.5	48.5	55	17	12.5	10
55925 00 010	8	1/8	5.5	23.5	44	49	14	14	10
55925 00 011	8	1/4	7	26	48.5	55	17	14	10
55925 00 012	8	3/8	8.5	27.5	56	65	20	14	10
55925 00 013	10	3/8	8.5	30.5	56	65	20	17	10
55925 00 014	12	3/8	8.5	32.5	56	65	20	21.5	10
55925 00 015	12	1/2	10	35	62	69	24	21.5	10

## 55902

**REGOLATORE UNIDIREZIONALE ORIENTABILE PER CILINDRO FILETTO CILINDRICO**  
 ORIENTING FLOW REGULATOR FOR CYLINDER (PARALLEL)  
 DURCHFLOSSREGLER ABLUFTDROSSELUNG (DREHBAR) MIT ZYL. GEWINDE  
 RÉGLEUR A L'ÉCHAPPEMENT FILETAGE CYLINDRIQUE  
 REGULADOR UNIDIRECCIONAL ORIENTABLE PARA CILINDRO ROSCA CILÍNDRICA  
 REGULADORA PARA CILINDRO UNIDIRECCIONAL ORIENTÁVEL COM ROSCA PARALELA

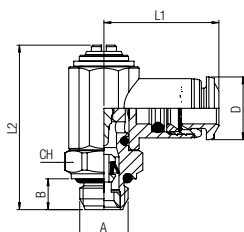
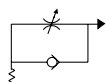

Code	Tube	A	B	L1	L2	CH	D	Pack.
55902 00 003	4	1/8	5.5	21.5	31	14	10	10
55902 00 008	6	1/8	5.5	23	31	14	12.5	10
55902 00 009	6	1/4	5.5	25.5	36.5	17	12.5	10
55902 00 010	8	1/8	5.5	23.5	31	14	14	10
55902 00 011	8	1/4	7	26	36.5	17	14	10
55902 00 012	8	3/8	8	27	42.5	20	14	10
55902 00 016	10	1/4	8	31	36.5	17	17	10
55902 00 013	10	3/8	8	30	42.5	20	17	10
55902 00 014	12	3/8	8	32	42.5	20	21.5	10
55902 00 015	12	1/2	9.5	34.5	47	24	21.5	10

## 55912

**REGOLATORE UNIDIREZIONALE ORIENTABILE PER VALVOLA FILETTO CILINDRICO**  
 ORIENTING FLOW REGULATOR FOR VALVE (PARALLEL)  
 DURCHFLOSSREGLER ZULUFTDROSSELUNG (DREHBAR) MIT ZYL. GEWINDE  
 RÉGLEUR A L'ADMISSION FILETAGE CYLINDRIQUE  
 REGULADOR UNIDIRECCIONAL ORIENTABLE PARA VÁLVULA ROSCA CILÍNDRICA  
 REGULADORA PARA VÁLVULA UNIDIRECCIONAL ORIENTÁVEL COM ROSCA PARALELA

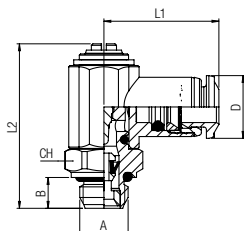
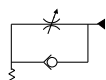

Code	Tube	A	B	L1	L2	CH	D	Pack.
55912 00 003	4	1/8	5.5	21.5	31	14	10	10
55912 00 008	6	1/8	5.5	23	31	14	12.5	10
55912 00 009	6	1/4	5.5	25.5	36.5	17	12.5	10
55912 00 010	8	1/8	5.5	23.5	31	14	14	10
55912 00 011	8	1/4	7	26	36.5	17	14	10
55912 00 012	8	3/8	8	27	42.5	20	14	10
55912 00 016	10	1/4	8	31	36.5	17	17	10
55912 00 013	10	3/8	8	30	42.5	20	17	10
55912 00 014	12	3/8	8	32	42.5	20	21.5	10
55912 00 015	12	1/2	9.5	34.5	47	24	21.5	10

## 55922

**REGOLATORE BIDIREZIONALE ORIENTABILE FILETTO CILINDRICO**  
 ORIENTING BI-DIRECTIONAL FLOW REGULATOR (PARALLEL)  
 DURCHFLOSSREGLER BI-DIREKTIONAL (DREHBAR) MIT ZYL. GEWINDE  
 RÉGLEUR BI-DIRECTIONNEL FILETAGE CYLINDRIQUE  
 REGULADOR BIDIRECCIONAL ORIENTABLE ROSCA CILÍNDRICA  
 REGULADORA BI-DIRECCIONAL ORIENTÁVEL COM ROSCA PARALELA

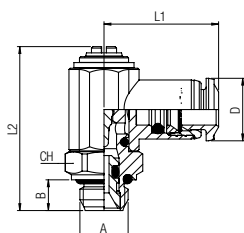

Code	Tube	A	B	L1	L2	CH	D	Pack.
55922 00 003	4	1/8	5.5	21.5	31	14	10	10
55922 00 008	6	1/8	5.5	23	31	14	12.5	10
55922 00 009	6	1/4	5.5	25.5	36.5	17	12.5	10
55922 00 010	8	1/8	5.5	23.5	31	14	14	10
55922 00 011	8	1/4	7	26	36.5	17	14	10
55922 00 012	8	3/8	8	27	42.5	20	14	10
55922 00 016	10	1/4	8	31	36.5	17	17	10
55922 00 013	10	3/8	8	30	42.5	20	17	10
55922 00 014	12	3/8	8	32	42.5	20	21.5	10
55922 00 015	12	1/2	9.5	34.5	47	24	21.5	10

## 55906

### REGOLATORE UNIDIREZIONALE ORIENTABILE PER CILINDRO FILETTO CILINDRICO

ORIENTING FLOW REGULATOR FOR CYLINDER (PARALLEL)

DURCHFLOSSREGLER ABLUFTDROSSELUNG (DREHBAR) MIT ZYL. GEWINDE

RÉGLEUR A L'ÉCHAPPEMENT FILETAGE CYLINDRIQUE

REGULADOR UNIDIRECCIONAL ORIENTABLE PARA CILINDRO ROSCA CILÍNDRICA

REGULADORA PARA CILINDRO UNIDIRECCIONAL ORIENTÁVEL COM ROSCA PARALELA

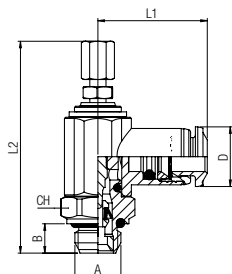
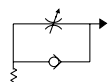

Code	Tube	A	B	L1	L2	CH	D	Pack.
55906 00 009	6	1/4	5.5	25.5	36.5	17	12.5	10
55906 00 010	8	1/8	5.5	23.5	31	14	14	10
55906 00 011	8	1/4	7	26	36.5	17	14	10
55906 00 012	8	3/8	8	27	42.5	20	14	10
55906 00 016	10	1/4	7	30.5	48.5	17	17	10
55906 00 013	10	3/8	8	30	42.5	20	17	10
55906 00 014	12	3/8	8	32	42.5	20	21.5	10
55906 00 015	12	1/2	9.5	34.5	47	24	21.5	10

## 55916

### REGOLATORE UNIDIREZIONALE ORIENTABILE PER VALVOLA FILETTO CILINDRICO

ORIENTING FLOW REGULATOR FOR VALVE (PARALLEL)

DURCHFLOSSREGLER ZULUFTDROSSELUNG (DREHBAR) MIT ZYL. GEWINDE

RÉGLEUR A L'ADMISSION FILETAGE CYLINDRIQUE

REGULADOR UNIDIRECCIONAL ORIENTABLE PARA VÁLVULA ROSCA CILÍNDRICA

REGULADORA PARA VÁLVULA UNIDIRECCIONAL ORIENTÁVEL COM ROSCA PARALELA

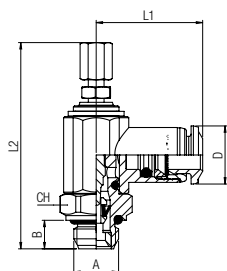
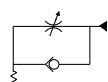

Code	Tube	A	B	L1	L2	CH	D	Pack.
55916 00 009	6	1/4	5.5	25.5	36.5	17	12.5	10
55916 00 010	8	1/8	5.5	23.5	31	14	14	10
55916 00 011	8	1/4	7	26	36.5	17	14	10
55916 00 012	8	3/8	8	27	42.5	20	14	10
55916 00 016	10	1/4	8	31	48.5	17	17	10
55916 00 013	10	3/8	8	30	42.5	20	17	10
55916 00 014	12	3/8	8	32	42.5	20	21.5	10
55916 00 015	12	1/2	9.5	34.5	47	24	21.5	10

## 55926

### REGOLATORE BIDIREZIONALE ORIENTABILE FILETTO CILINDRICO

ORIENTING BI-DIRECTIONAL FLOW REGULATOR (PARALLEL)

DURCHFLOSSREGLER BI-DIREKTIONAL (DREHBAR) MIT ZYL. GEWINDE

RÉGLEUR BI-DIRECTIONNEL FILETAGE CYLINDRIQUE

REGULADOR BIDIRECCIONAL ORIENTABLE ROSCA CILÍNDRICA

REGULADORA BI-DIRECCIONAL ORIENTÁVEL COM ROSCA PARALELA

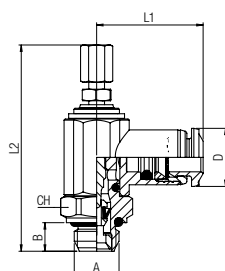

Code	Tube	A	B	L1	L2	CH	D	Pack.
55926 00 009	6	1/4	5.5	25.5	36.5	17	12.5	10
55926 00 010	8	1/8	5.5	23.5	31	14	14	10
55926 00 011	8	1/4	7	26	36.5	17	14	10
55926 00 012	8	3/8	8	27	42.5	20	14	10
55926 00 016	10	1/4	8	31	48.5	17	17	10
55926 00 013	10	3/8	8	30	42.5	20	17	10
55926 00 014	12	3/8	8	32	42.5	20	21.5	10
55926 00 015	12	1/2	9.5	34.5	47	24	21.5	10

## 56900

**REGOLATORE UNIDIREZIONALE ORIENTABILE PER CILINDRO FILETTO CILINDRICO**  
 ORIENTING FLOW REGULATOR FOR CYLINDER (PARALLEL)  
 DURCHFLUSSREGLER ABLUFTDROSSELUNG (DREHBAR) MIT ZYL. GEWINDE  
 RÉGLEUR A L'ÉCHAPPEMENT FILETAGE CYLINDRIQUE  
 REGULADOR UNIDIRECCIONAL ORIENTABLE PARA CILINDRO ROSCA CILÍNDRICA  
 REGULADORA PARA CILINDRO UNIDIRECCIONAL ORIENTÁVEL COM ROSCA PARALELA

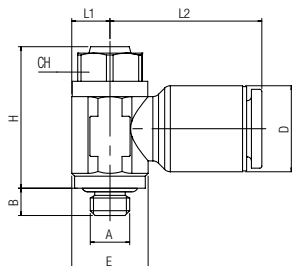
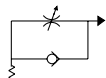

Code	Tube	A	B	H	E	L1	L2	D	CH	Pack.
56900 00 001	4	M5	3.6	18	9.5	4.5	16.5	8.5	8	10
56900 00 002	6	M5	3.6	18	9.5	4.5	19	10.5	8	10

## 56910

**REGOLATORE UNIDIREZIONALE ORIENTABILE PER VALVOLA FILETTO CILINDRICO**  
 ORIENTING FLOW REGULATOR FOR VALVE (PARALLEL)  
 DURCHFLUSSREGLER ZULUFTDROSSELUNG (DREHBAR) MIT ZYL. GEWINDE  
 RÉGLEUR A L'ADMISSION FILETAGE CYLINDRIQUE  
 REGULADOR UNIDIRECCIONAL ORIENTABLE PARA VÁLVULA ROSCA CILÍNDRICA  
 REGULADORA PARA VÁLVULA UNIDIRECCIONAL ORIENTÁVEL COM ROSCA PARALELA

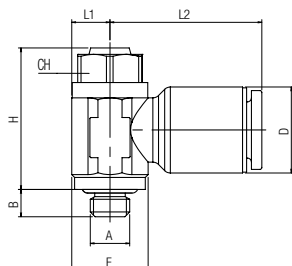
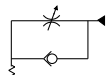

Code	Tube	A	B	H	E	L1	L2	D	CH	Pack.
56910 00 001	4	M5	3.6	18	9.5	4.5	16.5	8.5	8	10
56910 00 002	6	M5	3.6	18	9.5	4.5	19	10.5	8	10

## 56920

**REGOLATORE BIDIREZIONALE ORIENTABILE FILETTO CILINDRICO**  
 ORIENTING BI-DIRECTIONAL FLOW REGULATOR (PARALLEL)  
 DURCHFLUSSREGLER BI-DIREKTIONAL (DREHBAR) MIT ZYL. GEWINDE  
 RÉGLEUR BI-DIRECTIONNEL FILETAGE CYLINDRIQUE  
 REGULADOR BIDIRECCIONAL ORIENTABLE ROSCA CILÍNDRICA  
 REGULADORA BI-DIRECCIONAL ORIENTÁVEL COM ROSCA PARALELA

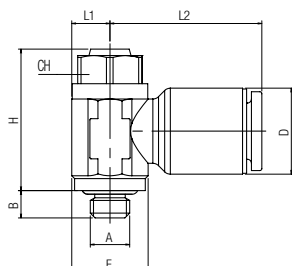

Code	Tube	A	B	H	E	L1	L2	D	CH	Pack.
56920 00 001	4	M5	3.6	18	9.5	4.5	16.5	8.5	8	10
56920 00 002	6	M5	3.6	18	9.5	4.5	19	10.5	8	10

## 56935

**REGOLATORE UNIDIREZIONALE ORIENTABILE PER CILINDRO FILETTO CILINDRICO**

ORIENTING FLOW REGULATOR FOR CYLINDER (PARALLEL)

DURCHFLUSSREGLER ABLUFTDROSSELUNG (DREHBAR) MIT ZYL. GEWINDE

RÉGLEUR A L'ÉCHAPPEMENT FILETAGE CYLINDRIQUE

REGULADOR UNIDIRECCIONAL ORIENTABLE PARA CILINDRO ROSCA CILÍNDRICA

REGULADORA PARA CILINDRO UNIDIRECCIONAL ORIENTÁVEL COM ROSCA PARALELA

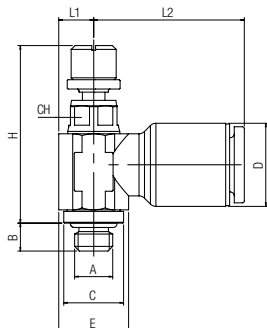
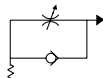

Code	Tube	A	B	H	E	C	L1	L2	D	CH	Pack.
56935 00 006	4	M3	3	21.5±24.5	9	7.5	4.5	17	8.5	6	10
56935 00 001	4	M5	3.6	21.5±24.5	9	7.5	4.5	17	8.5	6	10
56935 00 003	4	1/8	5	24±27.5	11.5	13.5	6.5	17	8.5	7	10
56935 00 002	6	M5	3.6	21.5±24.5	9	7.5	4.5	19.5	10.5	6	10
56935 00 004	6	1/8	5	24±27.5	11.5	13.5	6.5	19.5	10.5	7	10



## 56945

**REGOLATORE UNIDIREZIONALE ORIENTABILE PER VALVOLA FILETTO CILINDRICO**

ORIENTING FLOW REGULATOR FOR VALVE (PARALLEL)

DURCHFLUSSREGLER ZULUFTDROSSELUNG (DREHBAR) MIT ZYL. GEWINDE

RÉGLEUR A L'ADMISSION FILETAGE CYLINDRIQUE

REGULADOR UNIDIRECCIONAL ORIENTABLE PARA VÁLVULA ROSCA CILÍNDRICA

REGULADORA PARA VÁLVULA UNIDIRECCIONAL ORIENTÁVEL COM ROSCA PARALELA

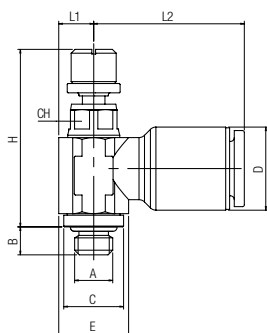
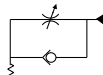

Code	Tube	A	B	H	E	C	L1	L2	D	CH	Pack.
56945 00 001	4	M5	3.6	21.5±24.5	9	7.5	4.5	17	8.5	6	10
56945 00 003	4	1/8	5	24±27.5	11.5	13.5	6.5	17	8.5	7	10
56945 00 002	6	M5	3.6	21.5±24.5	9	7.5	4.5	19.5	10.5	6	10
56945 00 004	6	1/8	5	24±27.5	11.5	13.5	6.5	19.5	10.5	7	10



## 56955

**REGOLATORE BIDIREZIONALE ORIENTABILE**

ORIENTING BI-DIRECTIONAL FLOW REGULATOR

DURCHFLUSSREGLER BI-DIREKTIONAL (DREHBAR)

RÉGLEUR DE DÉBIT BI-DIRECTIONNEL FILETAGE (ORIENTABLE)

REGULADOR BIDIRECCIONAL ORIENTABLE

REGULADORA BI-DIRECCIONAL ORIENTÁVEL

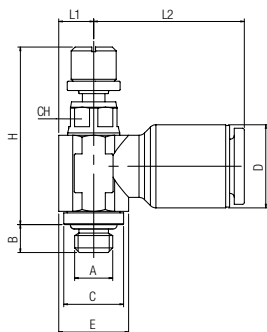
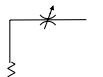

Code	Tube	A	B	H	E	C	L1	L2	D	CH	Pack.
56955 00 001	4	M5	3.6	21.5±24.5	9	7.5	4.5	17	8.5	6	10
56955 00 003	4	1/8	5	24±27.5	11.5	13.5	6.5	17	8.5	7	10
56955 00 002	6	M5	3.6	21.5±24.5	9	7.5	4.5	19.5	10.5	6	10
56955 00 004	6	1/8	5	24±27.5	11.5	13.5	6.5	19.5	10.5	7	10



## 57901

### REGOLATORE UNIDIREZIONALE ORIENTABILE PER CILINDRO "UNIVERSAL SHORT"

ORIENTING FLOW REGULATOR FOR CYLINDER "UNIVERSAL SHORT"  
 DURCHFLOSSREGLER ABLUFTDROSSELUNG (DREHBAR) "UNIVERSAL SHORT"  
 RÉGLEUR DE DÉBIT À L'ÉCHAPPEMENT FILETAGE (ORIENTABLE) "UNIVERSAL SHORT"  
 REGULADOR UNIDIRECCIONAL ORIENTABLE PARA CILINDRO "UNIVERSAL SHORT"  
 REGULADORA UNIDIRECCIONAL ORIENTÁVEL PARA CILINDRO ROSCA "UNIVERSAL SHORT"

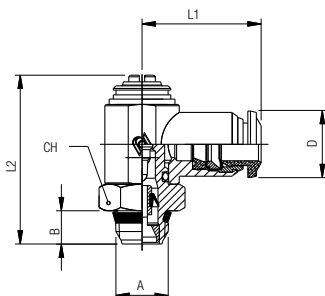
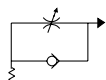

Code	Tube	A	B	L1	L2	CH	D	Pack.
57901 00 002	4	M5	4	19	29.5	8	10	10
57901 00 003	4	1/8	5.5	21	31	14	10	10
57901 00 004	5	M5	4	20	29.5	8	12.5	10
57901 00 005	5	1/8	5.5	21.5	31	14	12.5	10
57901 00 006	5	1/4	7	24.5	36.5	17	12.5	10
57901 00 007	6	M5	4	20.5	29.5	8	12.5	10
57901 00 008	6	1/8	5.5	22.5	31	14	12.5	10
57901 00 009	6	1/4	7	25	36.5	17	12.5	10
57901 00 010	8	1/8	5.5	24	31	14	14	10
57901 00 011	8	1/4	7	26	36.5	17	14	10
57901 00 016	8	3/8	7.5	28.5	42.5	20	14	10
57901 00 017	10	1/4	7	28.5	36.5	17	17	10
57901 00 012	10	3/8	7.5	30.5	42.5	20	17	10
57901 00 013	12	3/8	7.5	32.5	42.5	20	21.5	10
57901 00 014	12	1/2	9	35	47	24	21.5	10
57901 00 015	14	1/2	9	35.5	47	24	21.5	10

## 57910

### REGOLATORE UNIDIREZIONALE ORIENTABILE PER VALVOLA "UNIVERSAL SHORT"

ORIENTING FLOW REGULATOR FOR VALVE "UNIVERSAL SHORT"  
 DURCHFLOSSREGLER ZULUFTDROSSELUNG (DREHBAR) "UNIVERSAL SHORT"  
 RÉGLEUR DE DÉBIT À L'ADMISSION FILETAGE (ORIENTABLE) "UNIVERSAL SHORT"  
 REGULADOR UNIDIRECCIONAL ORIENTABLE PARA VÁLVULA "UNIVERSAL SHORT"  
 REGULADORA UNIDIRECCIONAL ORIENTÁVEL PARA VÁLVULA ROSCA "UNIVERSAL SHORT"

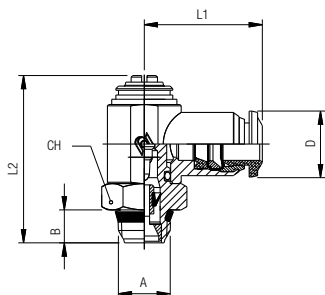
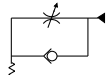

Code	Tube	A	B	L1	L2	CH	D	Pack.
57910 00 002	4	M5	4	19	29.5	8	10	10
57910 00 003	4	1/8	5.5	21	31	14	10	10
57910 00 004	5	M5	4	20	29.5	8	12.5	10
57910 00 005	5	1/8	5.5	21.5	31	14	12.5	10
57910 00 006	5	1/4	7	24.5	36.5	17	12.5	10
57910 00 007	6	M5	4	20.5	29.5	8	12.5	10
57910 00 008	6	1/8	5.5	22.5	31	14	12.5	10
57910 00 009	6	1/4	7	25	36.5	17	12.5	10
57910 00 010	8	1/8	5.5	24	31	14	14	10
57910 00 011	8	1/4	7	26	36.5	17	14	10
57910 00 016	8	3/8	7.5	28.5	42.5	20	14	10
57910 00 017	10	1/4	7	28.5	36.5	17	17	10
57910 00 012	10	3/8	7.5	30.5	42.5	20	17	10
57910 00 013	12	3/8	7.5	32.5	42.5	20	21.5	10
57910 00 014	12	1/2	9	35	47	24	21.5	10
57910 00 015	14	1/2	9	35.5	47	24	21.5	10

## 57920

### REGOLATORE BIDIREZIONALE ORIENTABILE "UNIVERSAL SHORT"

ORIENTING BI-DIRECTIONAL FLOW REGULATOR "UNIVERSAL SHORT"  
 DURCHFLOSSREGLER BI-DIREKTIONAL (DREHBAR) "UNIVERSAL SHORT"  
 RÉGLEUR DE DÉBIT BI-DIRECTIONNEL FILETAGE (ORIENTABLE) "UNIVERSAL SHORT"  
 REGULADOR BIDIRECCIONAL ORIENTABLE "UNIVERSAL SHORT"  
 REGULADORA BI-DIRECCIONAL ORIENTÁVEL ROSCA "UNIVERSAL SHORT"

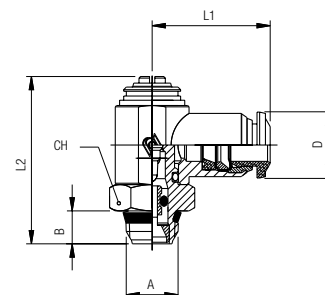

Code	Tube	A	B	L1	L2	CH	D	Pack.
57920 00 002	4	M5	4	19	29.5	8	10	10
57920 00 003	4	1/8	5.5	21	31	14	10	10
57920 00 004	5	M5	4	20	29.5	8	12.5	10
57920 00 005	5	1/8	5.5	21.5	31	14	12.5	10
57920 00 006	5	1/4	7	24.5	36.5	17	12.5	10
57920 00 007	6	M5	4	20.5	29.5	8	12.5	10
57920 00 008	6	1/8	5.5	22.5	31	14	12.5	10
57920 00 009	6	1/4	7	25	36.5	17	12.5	10
57920 00 010	8	1/8	5.5	24	31	14	14	10
57920 00 011	8	1/4	7	26	36.5	17	14	10
57920 00 016	8	3/8	7.5	28.5	42.5	20	14	10
57920 00 017	10	1/4	7	28.5	36.5	17	17	10
57920 00 012	10	3/8	7.5	30.5	42.5	20	17	10
57920 00 013	12	3/8	7.5	32.5	42.5	20	21.5	10
57920 00 014	12	1/2	9	35	47	24	21.5	10
57920 00 015	14	1/2	9	35.5	47	24	21.5	10

## 57905

**REGOLATORE UNIDIREZIONALE ORIENTABILE PER CILINDRO "UNIVERSAL SHORT"**

ORIENTING FLOW REGULATOR FOR CYLINDER "UNIVERSAL SHORT"

DURCHFLOSSREGLER ABLUFTDROSSELUNG (DREHBAR) "UNIVERSAL SHORT"

RÉGLEUR DE DÉBIT À L'ÉCHAPPEMENT FILETAGE (ORIENTABLE) "UNIVERSAL SHORT"

REGULADOR UNIDIRECCIONAL ORIENTABLE PARA CILINDRO "UNIVERSAL SHORT"

REGULADORA UNIDIRECCIONAL ORIENTÁVEL PARA CILINDRO ROSCA "UNIVERSAL SHORT"

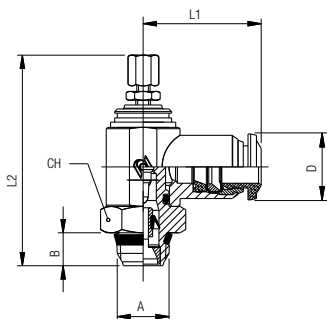
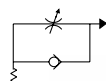

Code	Tube	A	B	L1	L2 min	L2 max	CH	D	Pack.
57905 00 002	4	M5	4	19	39.5	43.5	8	10	10
57905 00 003	4	1/8	5.5	21	44	49	14	10	10
57905 00 004	5	M5	4	20	39.5	43.5	8	12.5	10
57905 00 005	5	1/8	5.5	21.5	44	49	14	12.5	10
57905 00 006	5	1/4	7	24.5	48.5	55	17	12.5	10
57905 00 007	6	M5	4	20.5	39.5	43.5	8	12.5	10
57905 00 008	6	1/8	5.5	22.5	44	49	14	12.5	10
57905 00 009	6	1/4	7	25	48.5	55	17	12.5	10
57905 00 010	8	1/8	5.5	24	44	49	14	14	10
57905 00 011	8	1/4	7	26	48.5	55	17	14	10
57905 00 016	8	3/8	7.5	28.5	56	65	20	14	10
57905 00 017	10	1/4	7	28.5	48.5	55	17	17	10
57905 00 012	10	3/8	7.5	30.5	56	65	20	17	10
57905 00 013	12	3/8	7.5	32.5	56	65	20	21.5	10
57905 00 014	12	1/2	9	35	62	69	24	21.5	10
57905 00 015	14	1/2	9	35.5	62	69	24	21.5	10

## 57915

**REGOLATORE UNIDIREZIONALE ORIENTABILE PER VALVOLA "UNIVERSAL SHORT"**

ORIENTING FLOW REGULATOR FOR VALVE "UNIVERSAL SHORT"

DURCHFLOSSREGLER ZULUFTDROSSELUNG (DREHBAR) "UNIVERSAL SHORT"

RÉGLEUR DE DÉBIT À L'ADMISSION FILETAGE (ORIENTABLE) "UNIVERSAL SHORT"

REGULADOR UNIDIRECCIONAL ORIENTABLE PARA VÁLVULA "UNIVERSAL SHORT"

REGULADORA UNIDIRECCIONAL ORIENTÁVEL PARA VÁLVULA ROSCA "UNIVERSAL SHORT"

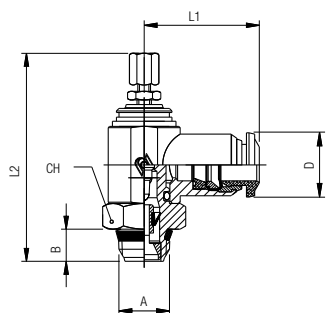
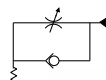

Code	Tube	A	B	L1	L2 min	L2 max	CH	D	Pack.
57915 00 002	4	M5	4	19	39.5	43.5	8	10	10
57915 00 003	4	1/8	5.5	21	44	49	14	10	10
57915 00 004	5	M5	4	20	39.5	43.5	8	12.5	10
57915 00 005	5	1/8	5.5	21.5	44	49	14	12.5	10
57915 00 006	5	1/4	7	24.5	48.5	55	17	12.5	10
57915 00 007	6	M5	4	20.5	39.5	43.5	8	12.5	10
57915 00 008	6	1/8	5.5	22.5	44	49	14	12.5	10
57915 00 009	6	1/4	7	25	48.5	55	17	12.5	10
57915 00 010	8	1/8	5.5	24	44	49	14	14	10
57915 00 011	8	1/4	7	26	48.5	55	17	14	10
57915 00 016	8	3/8	7.5	28.5	56	65	20	14	10
57915 00 017	10	1/4	7	28.5	48.5	55	17	17	10
57915 00 012	10	3/8	7.5	30.5	56	65	20	17	10
57915 00 013	12	3/8	7.5	32.5	56	65	20	21.5	10
57915 00 014	12	1/2	9	35	62	69	24	21.5	10
57915 00 015	14	1/2	9	35.5	62	69	24	21.5	10

## 57925

**REGOLATORE BIDIREZIONALE ORIENTABILE "UNIVERSAL SHORT"**

ORIENTING BI-DIRECTIONAL FLOW REGULATOR "UNIVERSAL SHORT"

DURCHFLOSSREGLER ABLUFTDROSSELUNG (DREHBAR) "UNIVERSAL SHORT"

RÉGLEUR DE DÉBIT BI-DIRECTIONNEL FILETAGE (ORIENTABLE) "UNIVERSAL SHORT"

REGULADOR BIDIRECCIONAL ORIENTABLE "UNIVERSAL SHORT"

REGULADORA BI-DIRECCIONAL ORIENTÁVEL ROSCA "UNIVERSAL SHORT"

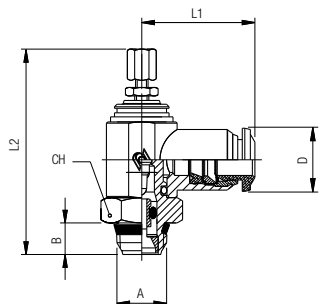

Code	Tube	A	B	L1	L2 min	L2 max	CH	D	Pack.
57925 00 002	4	M5	4	19	39.5	43.5	8	10	10
57925 00 003	4	1/8	5.5	21	44	49	14	10	10
57925 00 004	5	M5	4	20	39.5	43.5	8	12.5	10
57925 00 005	5	1/8	5.5	21.5	44	49	14	12.5	10
57925 00 006	5	1/4	7	24.5	48.5	55	17	12.5	10
57925 00 007	6	M5	4	20.5	39.5	43.5	8	12.5	10
57925 00 008	6	1/8	5.5	22.5	44	49	14	12.5	10
57925 00 009	6	1/4	7	25	48.5	55	17	12.5	10
57925 00 010	8	1/8	5.5	24	44	49	14	14	10
57925 00 011	8	1/4	7	26	48.5	55	17	14	10
57925 00 016	8	3/8	7.5	28.5	56	65	20	14	10
57925 00 017	10	1/4	7	28.5	48.5	55	17	17	10
57925 00 012	10	3/8	7.5	30.5	56	65	20	17	10
57925 00 013	12	3/8	7.5	32.5	56	65	20	21.5	10
57925 00 014	12	1/2	9	35	62	69	24	21.5	10
57925 00 015	14	1/2	9	35.5	62	69	24	21.5	10

## REGOLATORE DI PORTATA ORIENTABILE - CW 510L

CW 510L - ORIENTING FLOW REGULATOR  
 DURCHFLOSSREGLER (DREHBAR) - CW 510L  
 RÉGLEURS DE DÉBIT ORIENTABLES - CW 510L  
 REGULADORES DE CAUDAL ORIENTABLES - CW 510L  
 REGULADORAS DE VAZÃO ORIENTÁVELV - CW 510L

**CARATTERISTICHE TECNICHE**

TECHNICAL CHARACTERISTICS  
 TECHNISCHE ANGABEN  
 CARACTÉRISTIQUES TECHNIQUES  
 CARACTERÍSTICAS TÉCNICAS  
 CARACTERÍSTICAS TÉCNICAS

**Norma di Riferimento**

Reference standard

Entspricht der Norm

Norme de référence

Normativa de referencia

Norma de referência

**Materiali e Componenti**

- 1 Corpo in Ottone CW510L
- 2 Spillo di Regolazione in Ottone CW510L
- 3 Guarnizione O-ring FKM Alimentare

**IT**
**Component Parts and Materials**

- 1 CW510L brass body
- 2 CW510L Brass Adjusting needle
- 3 O-Ring seal in FKM Food

**GB**
**Komponenten und Materialien**

- 1 Körper Messing CW510L
- 2 Einstellnadel Messing CW510L
- 3 O-Ringdichtung FKM lebensmittelkonform

**DE**
**Matériaux et Composants**

- 1 Corps en laiton CW510L
- 2 Vis de réglage: laiton CW510L
- 3 Joint O-ring FKM qualité alimentaire

**FR**
**Materiales y componentes**

- 1 Cuerpo en latón CW510L
- 2 Tornillo de regulación en latón CW510L
- 3 Junta tórica en FKM alimentario

**ES**
**Materiais e Componentes**

- 1 Corpo em latão CW510L
- 2 Agulha de Regulagem em Latão CW510L
- 3 Vedação o-ring em FKM alimentício

**PT**

**Pressioni**

Pressures

Druckbereich

Pressions

Presiones

Pressões



**0.1 bar (0.01 MPa)**  
**10 bar (1 MPa)**

**Temperature**

Temperatures

Temperatur

Températures

Temperaturas

Temperaturas

**- 15 °C**  
**+ 190 °C**

**Fluidi compatibili**

Aria compressa / Vuoto / Acqua / Alimenti

Fluids

Compressed air / Vacuum / Water / Food

Geeignete Medien

Druckluft / Vakuum / Wasser / Lebensmittel

Fluides compatibles

Air comprimé / Vide / Eau / Boissons

Fluidos compatibles

Aire comprimido / Vacío / Agua / Alimentos

Fluidos compatíveis

Ar comprimido / Vácuo / Água / Alimentos



<b>Filettatura</b> Gas cilindrica conforme ISO 228 Classe A.	<b>IT</b>	<b>Threads</b> Parallel gas in conformity with ISO 228 Class A.	<b>GB</b>	<b>Gewindearten</b> Zylindrisches Gewinde nach Norm ISO 228 Classe A.	<b>DE</b>
<b>Filetages</b> Filetage cylindrique conforme: ISO 228 Class A.	<b>FR</b>	<b>Roscas</b> Gas cilíndrica conforme ISO 228 Clase A.	<b>ES</b>	<b>Roscas</b> Gas paralela conforme ISO 228 Classe A.	<b>PT</b>

# 6924

## REGOLATORE DI FLUSSO BIDIREZIONALE

BI-DIRECTIONAL FLOW REGULATOR  
 DURCHFLUSSREGLER BI-DIREKTIONAL  
 VIS RÉGLEUR DE DÉBIT BI-DIRECTIONNEL  
 TORNILLO REGULADOR BIDIRECCIONAL  
 REGULADORA DE VAZÃO BI-DIRECCIONAL



Code	A	C	B	L1	L2	CH	D	Pack.
<b>06924 000 02 CW</b>	<b>1/4</b>	<b>1/4</b>	7	22	39	17	16.5	25

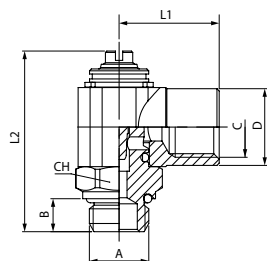

**REGOLATORI DI PORTATA SERIE 8900**

FLOW REGULATORS VALVES 8900 SERIES  
 DURCHFLUSSREGLER SERIE 8900  
 RÉGLEURS DE DÉBIT SÉRIE 8900  
 REGULADORES DE CAUDAL SERIE 8900  
 REGULADORAS DE VAZÃO SÉRIE 8900



**CARATTERISTICHE TECNICHE**

TECHNICAL CHARACTERISTICS  
 TECHNISCHE ANGABEN  
 CARACTÉRISTIQUES TECHNIQUES  
 CARACTERÍSTICAS TÉCNICAS  
 CARACTERÍSTICAS TÉCNICAS



**Norma di Riferimento**

Reference standard

Entspricht der Norm

Norme de référence

Normativa de referencia

Norma de referência

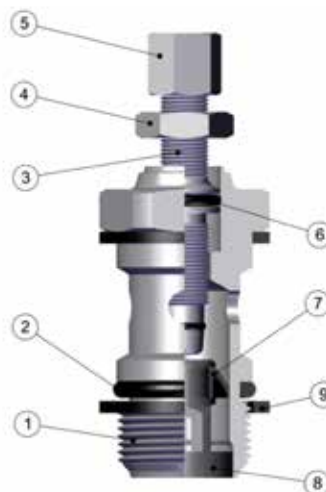

Materiali e Componenti	IT	Component Parts and Materials	GB	Komponenten und Materialien	DE
1 Corpo in Ottone nichelato		1 Nickel-plated Brass Body		1 Körper Messing vernickelt	
2 Guarnizione O-Ring in NBR		2 NBR O-RING Seals		2 O-Ring NBR	
3 Spillo di Regolazione in Ottone nichelato		3 Nickel-plated Brass Adjusting needle		3 Einstellnadel Messing vernickelt	
4 Ghiera di bloccaggio in Ottone nichelato		4 Nickel-plated Brass Locking nut		4 Kontermutter Messing vernickelt	
5 Pomolo di comando in ottone Nichelato		5 Nickel-plated Brass Adjusting knob		5 Einstellknopf Messing vernickelt	
6 Guarnizione O-Ring in NBR		6 NBR O-RING Seals		6 O-Ring NBR	
7 Guarnizione a labbro in NBR		7 NBR Lip seal		7 Lippendichtung NBR	
8 Supporto guarnizione in ottone Nichelato		8 Nickel-plated Brass Seal support		8 Dichtungs Unterstützung Messing vernickelt	
9 Rondella PA66 Art.1610		9 PA66 Washer Art.1610		9 Dichtring PA66 Art.1610	

Matériaux et Composants	FR	Materiales y Componentes	ES	Materiais e Componentes	PT
1 Corps: laiton nickelé		1 Cuerpo en latón niquelado		1 Corpo em Latão niquelado	
2 Joint torique: NBR		2 Junta tórica O-Ring en NBR		2 Vedação O-Ring em NBR	
3 Vis de réglage: laiton nickelé		3 Tornillo de regulación en latón niquelado		3 Agulha de Regulagem em Latão niquelado	
4 Ecrou de blocage: laiton nickelé		4 Tuerca de bloqueo en latón niquelado		4 Porca de travamento em Latão niquelado	
5 Tête de réglage: laiton nickelé		5 Pomo de mando en latón niquelado		5 Cabeça de regulagem em Latão niquelado	
6 Joint torique: NBR		6 Junta tórica O-Ring en NBR		6 Vedação O-Ring em NBR	
7 Joint à lèvres: NBR		7 Junta de labio en NBR		7 Vedação interna em NBR	
8 Support de joint: laiton nickelé		8 Soporte junta en latón niquelado		8 Suporte da vedação em Latão niquelado	
9 Joint: PA66 Art.1610		9 Arandela en nylon Art. 1610		9 Arruela PA66 Cód.1610	



**Pressioni**

Pressures

Druckbereich

Pressions

Presiones

Pressões

**1 bar** (0.1 MPa)

**10 bar** (1 MPa)



**Temperature**

Temperatures

Temperatur

Temperatures

Temperaturas

Temperaturas

**- 20 °C**

**+ 80 °C**



**Fluidi compatibili**

Aria compressa

Fluids

Compressed air

Geeignete Medien

Druckluft

Fluides compatibles

Air comprimé

Fluidos compatibles

Aire comprimido

Fluidos compatíveis

Ar comprimido



<b>Filettatura</b> Gas cilindrica conforme ISO 228 Classe A.	<b>IT</b> <b>Threads</b> Parallel gas in conformity with ISO 228 Class A.	<b>GB</b> <b>Gewindearten</b> Zylindrisches Gewinde nach Norm ISO 228 Classe A.	<b>DE</b>
<b>Filetages</b> Filetage cylindrique conforme: ISO 228 Classe A.	<b>FR</b> <b>Roscas</b> Gas cilíndrica conforme ISO 228 Clase A.	<b>ES</b> <b>Roscas</b> Gas paralela conforme ISO 228 Classe A.	<b>PT</b>

- C** **UNIDIREZIONALE PER CILINDRO**
- UNI-DIRECTIONAL FOR CYLINDER
  - DROSSELUNG FÜR ZYLINDER (ABLUF)
  - UNIDIRECTIONNEL À L'ÉCHAPPEMENT
  - UNIDIRECCIONAL PARA CILINDRO
  - UNIDIRECCIONAL PARA CILINDRO

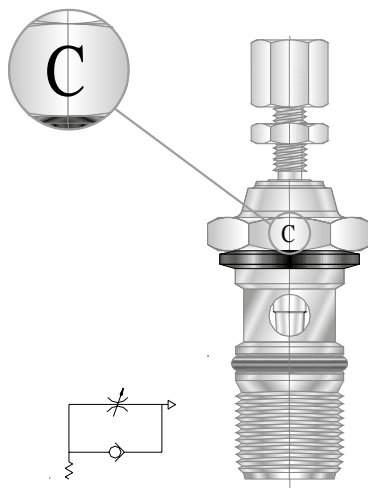

**CODE:**  
**8900 - 8905**

- V** **UNIDIREZIONALE PER VAVOLA**
- UNI-DIRECTIONAL FOR VALVE
  - DROSSELUNG FÜR ZYLINDER (ZULUF)
  - UNIDIRECTIONNEL À L'ADMISSION
  - UNIDIRECCIONAL PARA VÁLVULA
  - UNIDIRECCIONAL PARA VÁLVULA

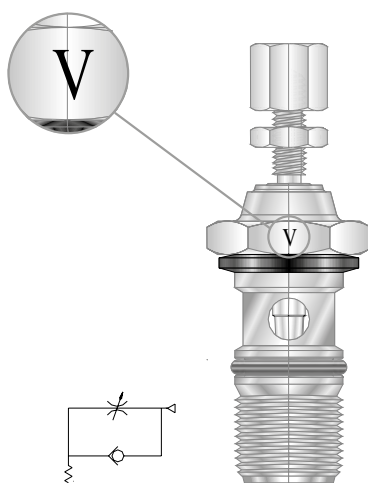

**CODE:**  
**8910 - 8915**

- B** **BIDIREZIONALE**
- BI-DIRECTIONAL
  - BI-DIRECCIONAL (OHNE RÜCKSCHLAG)
  - BI-DIRECTIONNEL
  - BIDIRECCIONAL
  - BI-DIRECCIONAL

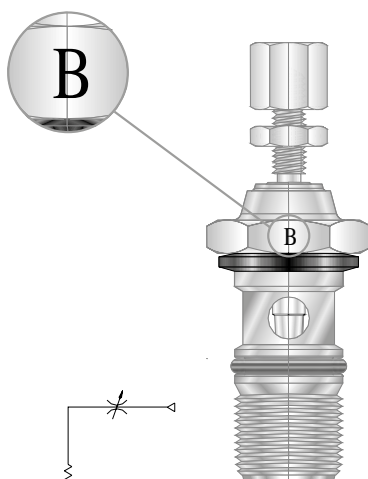

**CODE:**  
**8920 - 8925**

## 8900

### REGOLATORE DI FLUSSO UNIDIREZIONALE PER CILINDRO

FLOW REGULATOR FOR CYLINDER

DURCHFLUSSREGLER ABLUFTDROSSELUNG

VIS RÉGLEUR DE DÉBIT À L'ÉCHAPPEMENT

TORNILLO REGULADOR UNIDIRECCIONAL PARA CILINDRO

REGULADORA DE VAZÃO UNIDIRECCIONAL PARA CILINDRO

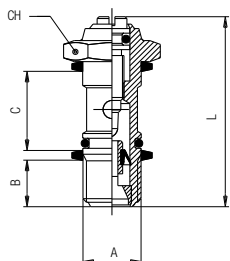
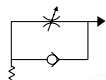

Code	A	B	C	L	CH	Pack.
08900 00 001	M5	4	12.5	24	8	10
08900 00 002	1/8	5.5	15	30.5	14	10
08900 00 003	1/4	8.5	17	35.5	17	10
08900 00 004	3/8	9	20	41	20	10
08900 00 005	1/2	10	24	47	24	10



## 8910

### REGOLATORE DI FLUSSO UNIDIREZIONALE PER VALVOLA

FLOW REGULATOR FOR VALVE

DURCHFLUSSREGLER ZULUFTDROSSELUNG

VIS RÉGLEUR DE DÉBIT À L'ADMISSION

TORNILLO REGULADOR UNIDIRECCIONAL PARA VÁLVULA

REGULADORA DE VAZÃO UNIDIRECCIONAL PARA VÁLVULA

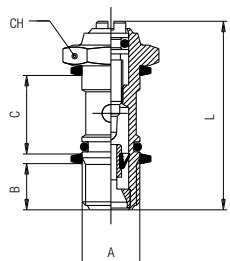
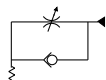

Code	A	B	C	L	CH	Pack.
08910 00 001	M5	4	12.5	24	8	10
08910 00 002	1/8	5.5	15	30.5	14	10
08910 00 003	1/4	8.5	17	35.5	17	10
08910 00 004	3/8	9	20	41	20	10
08910 00 005	1/2	10	24	47	24	10



## 8920

### REGOLATORE DI FLUSSO BIDIREZIONALE

BI-DIRECTIONAL FLOW REGULATOR

DURCHFLUSSREGLER BI-DIREKTIONAL

VIS RÉGLEUR DE DÉBIT BI-DIRECTIONNEL

TORNILLO REGULADOR BIDIRECCIONAL

REGULADORA DE VAZÃO BI-DIRECCIONAL

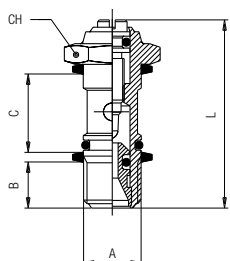

Code	A	B	C	L	CH	Pack.
08920 00 001	M5	4	12.5	24	8	10
08920 00 002	1/8	5.5	15	30.5	14	10
08920 00 003	1/4	8.5	17	35.5	17	10
08920 00 004	3/8	9	20	41	20	10
08920 00 005	1/2	10	24	47	24	10



## 8905

### REGOLATORE DI FLUSSO UNIDIREZIONALE PER CILINDRO

FLOW REGULATOR FOR CYLINDER

DURCHFLUSSREGLER ABLUFTDROSSELUNG

VIS RÉGLEUR DE DÉBIT À L'ÉCHAPPEMENT

TORNILLO REGULADOR UNIDIRECCIONAL PARA CILINDRO

REGULADORA DE VAZÃO UNIDIRECCIONAL PARA CILINDRO

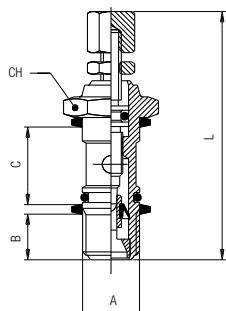
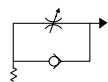

Code	A	B	C	L min	L max	CH	Pack.
08905 00 001	M5	4	12.5	33	37.5	8	10
08905 00 002	1/8	5.5	15	41	46.5	14	10
08905 00 003	1/4	8.5	17	46.5	52.5	17	10
08905 00 004	3/8	9	20	56.5	63.5	20	10
08905 00 005	1/2	10	24	62	69.5	24	10



## 8915

### REGOLATORE DI FLUSSO UNIDIREZIONALE PER VALVOLA

FLOW REGULATOR FOR VALVE

DURCHFLUSSREGLER ZULUFTDROSSELUNG

VIS RÉGLEUR DE DÉBIT À L'ADMISSION

TORNILLO REGULADOR UNIDIRECCIONAL PARA VÁLVULA

REGULADORA DE VAZÃO UNIDIRECCIONAL PARA VÁLVULA

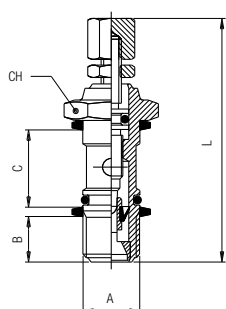
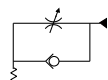

Code	A	B	C	L min	L max	CH	Pack.
08915 00 001	M5	4	12.5	33	37.5	8	10
08915 00 002	1/8	5.5	15	41	46.5	14	10
08915 00 003	1/4	8.5	17	46.5	52.5	17	10
08915 00 004	3/8	9	20	56.5	63.5	20	10
08915 00 005	1/2	10	24	62	69.5	24	10



## 8925

### REGOLATORE DI FLUSSO BIDIREZIONALE

BI-DIRECTIONAL FLOW REGULATOR

DURCHFLUSSREGLER BI-DIREKTIONAL

VIS RÉGLEUR DE DÉBIT BI-DIRECTIONNEL

TORNILLO REGULADOR BIDIRECCIONAL

REGULADORA DE VAZÃO BI-DIRECCIONAL

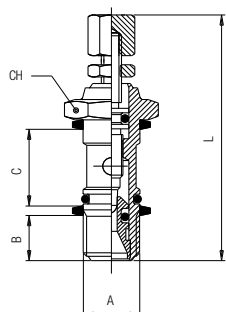

Code	A	B	C	L min	L max	CH	Pack.
08925 00 001	M5	4	12.5	33	37.5	8	10
08925 00 002	1/8	5.5	15	41	46.5	14	10
08925 00 003	1/4	8.5	17	46.5	52.5	17	10
08925 00 004	3/8	9	20	56.5	63.5	20	10
08925 00 005	1/2	10	24	62	69.5	24	10





**Montaggio**

Assembling

Montageanleitung

Assemblage

Montaje

Montagem

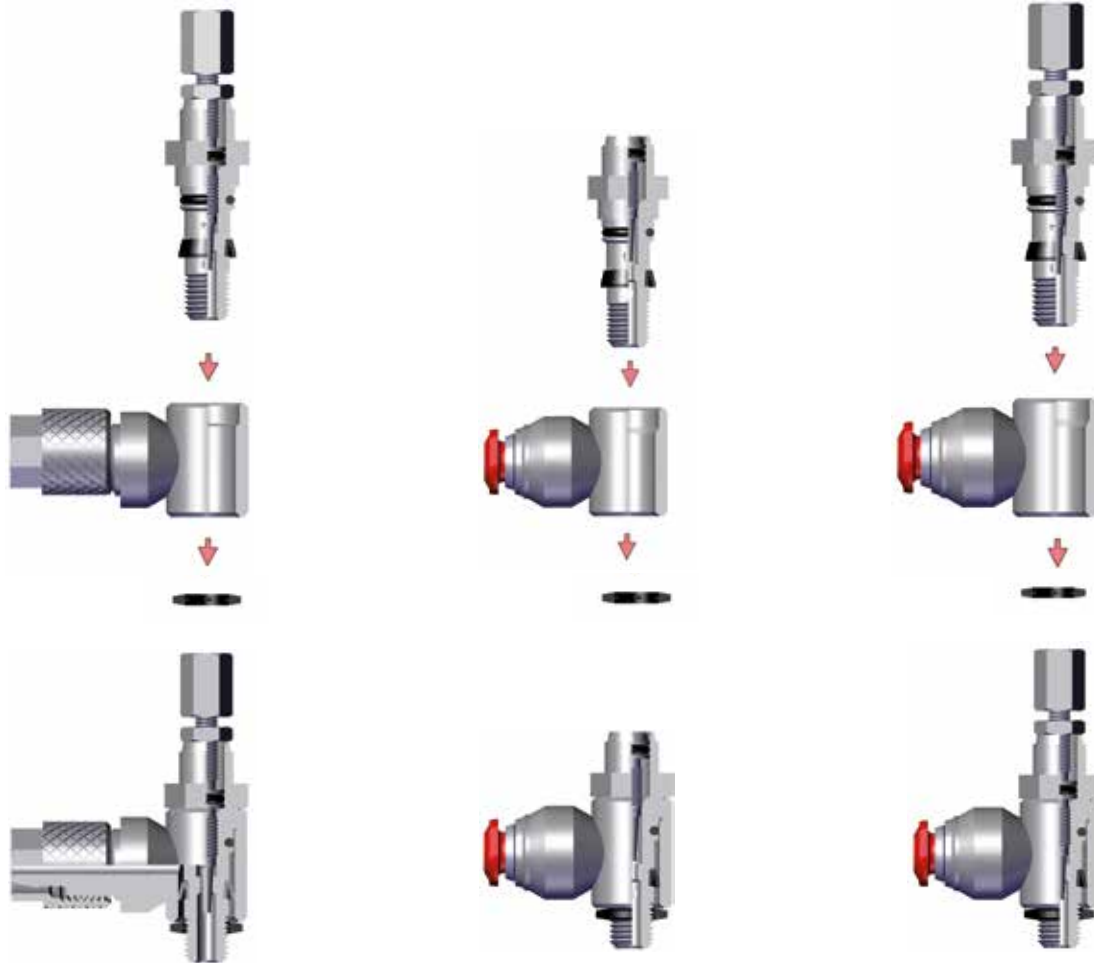

**IT**

Nelle tabelle che seguono riportiamo le misure di raccordi ad occhio che possono essere montati con i regolatori serie 8900.

Le misure dell'art. 1500 sono state estrapolate dalla tabella dell'articolo stesso. Gli art. 50505 e 57505 sono invece raccordi prodotti appositamente per questa serie di regolatori di flusso da M5.

**ATTENZIONE:** I Regolatori di portata da M5 devono essere accoppiati con i raccordi orientabili da M6.

Durante l'inserimento del regolatore nell'occhiello prestare attenzione a non rivoltare il labbro della guarnizione.

In the following tables specify the sizes of the single banjo bodies which can be assembled with 8900 Series regulators.

The sizes the art. 1500 have been taken from the standard single banjo bodies table. Art. 50505 and 57505 are special single banjo bodies produced suitably for the of flow regulators M5 range.

**ATTENTION:** The Flow Regulators size M5 must be assembled with orienting fittings size M6.

When you assemble the flow regulator into the banjo body, please be careful not damage the seal.

**GB**

In den folgenden Tabellen spezifizieren wir die Abmessungen der einfachen Ringanschlüsse, welche mit den 8900 Drosseln montiert werden können.

Die Abmessungen vom Artikel 1500 wurden der Tabelle des einfachen Standard-Ringanschlusses entnommen. Die Ringanschlüsse der Serie 50505 wurden speziell für das Sortiment der M5 Drosseln angefertigt.

**ACHTUNG:**Die Durchflussregler mit M5 müssen mit den Hohlsschrauben für M6 montiert werden.

Bei der Montage des Durchflussreglers in die Hohlsschraube ist darauf zu achten, dass die Lippendichtung nicht verletzt oder umgedreht wird.

**DE**

**FR**

Les tableaux ci-dessous indiquent les dimensions des corps banjo simples, qui peuvent être assemblés avec les régulateurs de débit 8900.

Les articles 1500 correspondent aux dimensions du corps standards. Les corps banjo de la série 50505 ont été spécialement conçus pour être assemblés sur les régleurs de débit M5.

**ATTENTION:** Les régleurs de débit M5 doivent être assemblés avec un corps banjo pour une vis de M6.

Lors de l'assemblage du RÉGLEUR de débit dans le corps du banjo, veuillez faire attention de ne pas blesser ou retourner le joint à lèvres.

En las tablas que siguen a continuación se especifican las medidas de los racores orientables que pueden ser montados con los reguladores 8900.

Las medidas del artículo 1500 han sido extrapoladas de la tabla del mismo artículo. El artículo 50505 es un artículo especial producido a propósito para esta serie de reguladores de flujo de M5.

**ATENCIÓN:** Los reguladores de flujo de M5 deben ser acoplados con los racores orientables de M6.

Durante la inserción del regulador en el anillo orientable prestar atención a no girar el labio de la junta.

**ES**

Nas tabelas que seguem apresentamos os tamanhos de conexões orientáveis que podem ser montados com os reguladoras 8900.

Os tamanhos da série de cód. 1500 são os mesmos das tabelas referentes aos banjos padrão. Os cód. 50505 e 57505 são por sua vez itens produzidos especialmente para esta série de reguladoras de vazão de tamanho M5.

**ATENÇÃO:** Os reguladoras de vazão M5 devem ser acoplados comas conexões orientáveis de tamanho M6.

Durante a inserção do reguladora no haste do banjo tenha cuidado para não danificar o lábio da vedação.

**PT**

## 1500

### ANELLO ORIENTABILE A L (PER REGOLATORI DI PORTATA M5)

SINGLE BANJO BODY (ADJUSTABLE RESTRICTOR VALVES M5)

RINGANSCHLUSS (FÜR DURCHFLUSSREGLER M5)

CORPS BANJO SIMPLE (POUR RÉGLEUR DE DÉBIT M5)

ANILLO ORIENTABLE SIMPLE (PARA REGULADOR DE CAUDAL M5)

ANEL ORIENTÁVEL EM "L" (PARA REGULADORAS DE VAZÃO M5)

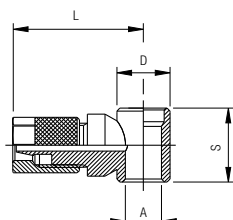

Code	Tube	A	D	S	L	Pack.
01500 00 002	4/2.7	M6	9	12.5	21.5	10
01500 00 007	6/4	M6	9	12.5	21.5	10

Questo articolo è prodotto appositamente per regolatori di portata da M5.

This article has been produced suitably for the Adjustable Restrictor valves M5.

Dieser Artikel ist speziell für den Durchflussregler mit M5 hergestellt.

Ces articles sont fabriqués spécialement pour les régleurs M5.

Este artículo se produce a propósito para los reguladores de flujo de M5.

Este item é produzido especialmente para utilização nas válvulas de tamanho M5.

## 1500

### ANELLO ORIENTABILE A L

SINGLE BANJO BODY

RINGANSCHLUSS

CORPS BANJO SIMPLE

ANILLO ORIENTABLE SIMPLE

ANEL ORIENTÁVEL EM "L"

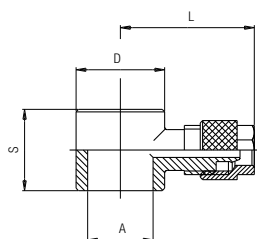

Code	Tube	A	D	S	L	Pack.
01500 00 003	4/2.7	1/8	14	15	22.5	10
01500 00 005	5/3	1/8	14	15	22.5	10
01500 00 008	6/4	1/8	14	15	23	10
01500 00 009	6/4	1/4	18	17	25	10
01500 00 010	6/4	3/8	21	20	27	10
01500 00 011	8/6	1/8	14	15	24.5	10
01500 00 012	8/6	1/4	18	17	26	10
01500 00 013	8/6	3/8	21	20	27	10
01500 00 014	8/6	1/2	26	24	31	10
01500 00 015	10/8	1/8	14	15	27.5	10
01500 00 016	10/8	1/4	18	17	27.5	10
01500 00 017	10/8	3/8	21	20	30.5	10
01500 00 018	10/8	1/2	26	24	34	10
01500 00 019	12/10	3/8	21	20	31.5	10
01500 00 020	12/10	1/2	26	24	35	10
01500 00 021	15/12.5	1/2	26	24	36.5	10

## 50505

### ANELLO ORIENTABILE A L (PER REGOLATORI DI PORTATA M5)

SINGLE BANJO BODY (ADJUSTABLE RESTRICTOR VALVES M5)

RINGANSCHLUSS (FÜR DURCHFLUSSREGLER M5)

CORPS BANJO SIMPLE (POUR RÉGLEUR DE DÉBIT M5)

ANILLO ORIENTABLE SIMPLE (PARA REGULADOR DE CAUDAL DE M5)

ANEL ORIENTÁVEL EM "L" (PARA REGULADORAS DE VAZÃO M5)

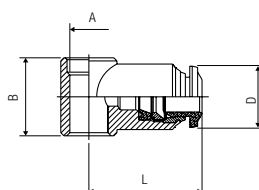

Code	Tube	A	B	L	D	Pack.
50505 00 005	3	M6	12.5	19	10	10
50505 00 001	4	M6	12.5	19	10	10
50505 00 003	5	M6	12.5	20	12.5	10
50505 00 004	6	M6	12.5	20.5	12.5	10

Questo articolo è prodotto appositamente per regolatori di portata da M5.

This article has been produced suitably for the adjustable restrictor valves M5.

Dieser Artikel ist speziell für den Durchflussregler mit M5 hergestellt.

Ces articles sont fabriqués spécialement pour les régleurs M5.

Este artículo se produce a propósito para los reguladores de flujo de M5.

Este item é produzido especialmente para utilização nas válvulas de tamanho M5.

## 50500

**ANELLO ORIENTABILE A L**  
 SINGLE BANJO BODY  
 RINGANSCHLUSS  
 CORPS BANJO SIMPLE  
 ANILLO ORIENTABLE SIMPLE  
 ANEL ORIENTÁVEL EM "L"

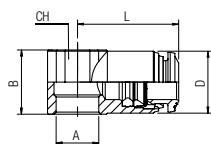

Code	Tube	A	B	L	CH	D	Pack.
50500 00 003	4	1/8	15	21	14	10	10
50500 00 014	5	1/8	15	21.5	14	12.5	10
50500 00 015	5	1/4	17	24.5	18	12.5	10
50500 00 004	6	1/8	15	22	14	12.5	10
50500 00 005	6	1/4	17	25	18	12.5	10
50500 00 006	8	1/8	15	24	14	14	10
50500 00 007	8	1/4	17	26	18	14	10
50500 00 008	8	3/8	20	28	21	14	10
50500 00 009	10	1/4	17	29	18	17	10
50500 00 010	10	3/8	20	30.5	21	17	10
50500 00 012	12	3/8	20	32.5	21	21.5	10
50500 00 021	12	1/2	24	35	25	21.5	10
50500 00 022	14	1/2	24	35.5	25	21.5	10

## 57505

**ANELLO ORIENTABILE A L (PER REGOLATORI DI PORTATA M5)**  
 SINGLE BANJO BODY (ADJUSTABLE RESTRICTOR VALVES M5)  
 RINGANSCHLUSS (FÜR DURCHFLUSSREGLER M5)  
 CORPS BANJO SIMPLE (POUR RÉGLEUR DE DÉBIT M5)  
 ANILLO ORIENTABLE SIMPLE (PARA REGULADOR DE CAUDAL DE M5)  
 ANEL ORIENTÁVEL EM "L" (PARA REGULADORAS DE VAZÃO M5)

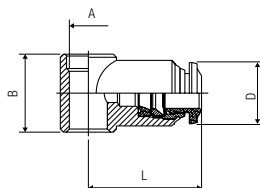

Code	Tube	A	B	L	D	Pack.
*57505 00 001	4 (5/32)	M6	12.5	18.5	10.5	10
57505 00 003	5	M6	12.5	20	12.5	10
57505 00 004	6	M6	12.5	21.5	12.5	10

Questo articolo è prodotto appositamente per regolatori di portata da M5.  
 This article has been produced suitably for the adjustable restrictor valves M5.  
 Dieser Artikel ist speziell für den Durchflussregler mit M5 hergestellt.  
 Ces articles sont fabriqués spécialement pour les régleurs M5.  
 Este artículo se produce a propósito para los reguladores de flujo de M5.  
 Este item é produzido especialmente para utilização nas válvulas de tamanho M5.

- \* Articolo in comune con serie 89000.
- \* Item in common with series 89000.
- \* Gegenstände gemeinsam mit Serie 89000.
- \* Pour les produits en commun avec la série 89000.
- \* Artículos en común con la serie 89000.
- \* Código em comum com a série 89000.

## 57500

**ANELLO ORIENTABILE A L**  
 SINGLE BANJO BODY  
 RINGANSCHLUSS  
 CORPS BANJO SIMPLE  
 ANILLO ORIENTABLE SIMPLE  
 ANEL ORIENTÁVEL EM "L"

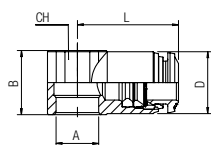

Code	Tube	A	B	L	CH	D	Pack.
57500 00 003	4	1/8	15	21	14	10	10
57500 00 014	5	1/8	15	21.5	14	12.5	10
57500 00 015	5	1/4	17	24.5	18	12.5	10
57500 00 004	6	1/8	15	22	14	12.5	10
57500 00 005	6	1/4	17	25	18	12.5	10
57500 00 006	8	1/8	15	24	14	14	10
57500 00 007	8	1/4	17	26	18	14	10
57500 00 008	8	3/8	20	28	21	14	10
57500 00 009	10	1/4	17	29	18	17	10
57500 00 010	10	3/8	20	30.5	21	17	10
57500 00 012	12	3/8	20	32.5	21	21.5	10
57500 00 021	12	1/2	24	35	25	21.5	10
57500 00 022	14	1/2	24	35.5	25	21.5	10

## 89505

### ANELLO ORIENTABILE A L (PER REGOLATORI DI PORTATA M5)

SINGLE BANJO BODY (ADJUSTABLE RESTRICTOR VALVES M5)

RINGANSCHLUSS (FÜR DURCHFLUSSREGLER M5)

CORPS BANJO SIMPLE (POUR RÉGLEUR DE DÉBIT M5)

ANILLO ORIENTABLE SIMPLE (PARA REGULADOR DE CAUDAL DE M5)

ANEL ORIENTÁVEL EM "L" (PARA REGULADORAS DE VAZÃO M5)

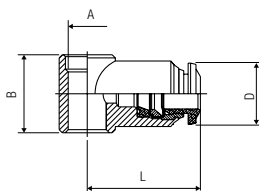

Code	Tube	A	B	L	D	Pack.
*57505 00 001	5/32 (4)	M6	12.5	18.5	10.5	10
89505 00 001	1/8	M6	12.5	16.5	10.5	10
89505 00 003	1/4	M6	12.5	21.5	12.5	10

Questo articolo è prodotto appositamente per Regolatori di Portata da M5.

This article has been produced suitably for the Adjustable Restrictor valves M5.

Dieser Artikel ist speziell für den Durchflussregler mit M5 hergestellt.

Ces articles sont fabriqués spécialement pour les régleurs M5.

Este artículo se produce a propósito para los reguladores de flujo de M5.

Este item é produzido especialmente para utilização nas válvulas de tamanho M5.

\* Articolo in comune con serie 57000.

\* Item in common with series 57000.

\* Gegenstände gemeinsam mit Serie 57000.

\* Pour les produits en commun avec la série 57000.

\* Artículos en común con la serie 57000.

\* Código em comum com a série 57000.

## 6090

### ANELLO ORIENTABILE A L FEMMINA

FEMALE SINGLE BANJO BODY

RINGANSCHLUSS INNENGEW

CORPS BANJO TARAUDE

ANILLO ORIENTABLE HEMBRA

ANEL ORIENTÁVEL EM "L" COM ROSCA FÊMEA

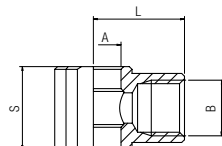

Code	B	A	L	S	Pack.
06090 00 01 02 NB	1/8	10	16.5	15	10
06090 00 01 03 NB	1/4	13	22	17	10
06090 00 01 04 NB	3/8	16.7	26	20	10

\* Montare su viti: (Cod. 51410, 51420, 51430, 51440)

\* Mounting on screws: (Cod. 51410, 51420, 51430, 51440)

\* Montage auf Schrauben: (Cod. 51410, 51420, 51430, 51440)

\* Montage sur vis: (Cod. 51410, 51420, 51430, 51440)

\* Montaje en tornillos: (Cod. 51410, 51420, 51430, 51440)

\* Montagem nos parafusos: (Cod. 51410, 51420, 51430, 51440)

**CARATTERISTICHE DI FLUSSO REGOLATORI DI PORTATA UNIDIREZIONALI E BIDIREZIONALI**
*FLOW CHARACTERISTICS ADJUSTABLE RESTRICTOR VALVES UNI-DIRECTIONALS AND BI-DIRECTIONALS*
*DURCHFLOSSWERTE DER REGLER MIT- ODER OHNE RÜCKSCHLAG*
*CARACTÉRISTIQUES DES DÉBITS POUR LES RÉGLEURS DE DÉBIT UNI ET BI-DIRECTIONNEL*
*CARACTERÍSTICAS DE FLUJO REGULADORES DE CAUDAL UNIDIRECCIONALES Y BIDIRECCIONALES*
*CARACTERÍSTICAS DE VAZÃO REGULADORAS DE VAZÃO UNIDIRECCIONAIS E BI-DIRECCIONAIS*
**IT**

Ripetiamo in questa pagina le caratteristiche di flusso dei regolatori per una corretta scelta della misura che più si adatta ad ogni specifico impiego.

**GB**

In this page you can find the flow characteristics of the regulators, which will help you to chose the most suitable size to satisfy every specific use.

**DE**

Auf dieser Seite sind die Durchflusswerte der Regler angegeben, damit für die gewünschte Anwendung der richtige Regler eingesetzt werden kann.

**FR**

Caractéristiques des débits des régleurs afin de déterminer la taille la plus appropriée pour satisfaire chaque utilisation.

**ES**

Encontramos en esta página las características de flujo de los reguladores para una correcta elección de la medida que más se adapte a cada uso específico.

**PT**

Nesta página são mostradas as características de vazão das reguladoras para uma correta escolha do tamanho que mais se adapta a cada aplicação específica.

**NI/min**

Portata d'aria Q a 0°C e 1013 mbar

*Air rate Q at 0°C and 1013 mbar*

*Luftdurchlass Q bei 0°C und 1013 mbar*

*Débit d'air Q à 0°C et 1013 mbar*

*Caudal de Aire Q 0°C y 1013 mbar*

*Vazão de ar Q 0°C e 1013 mbar*

**N°**

Numero giri spillo di regolazione

*Number of turns of the adjusting needle*

*Umdrehungen an der Einstellnadel*

*Nombre de tours de réglage*

*Número de giros tornillo regulador*

*Número de voltas do parafuso de regulagem*

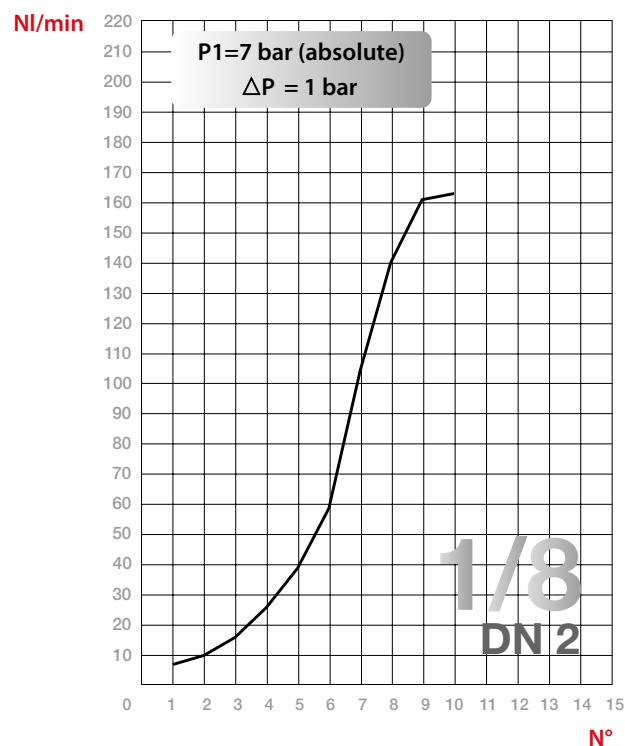
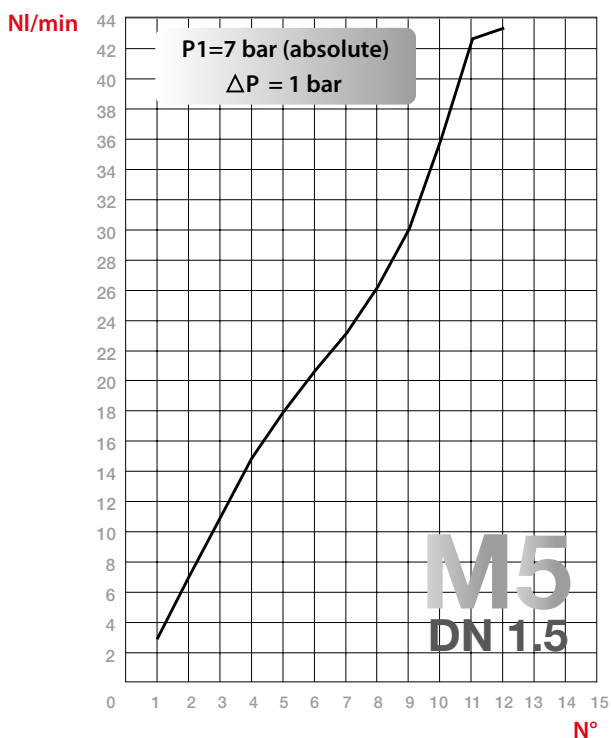

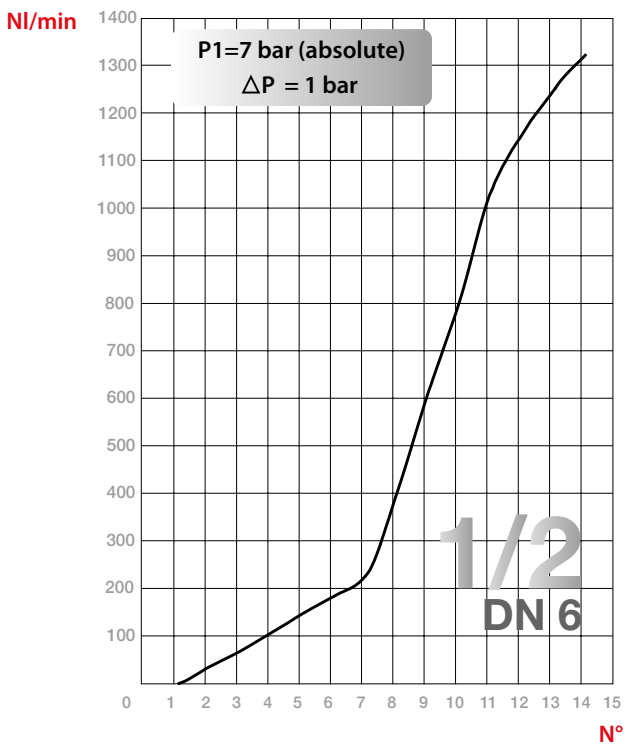
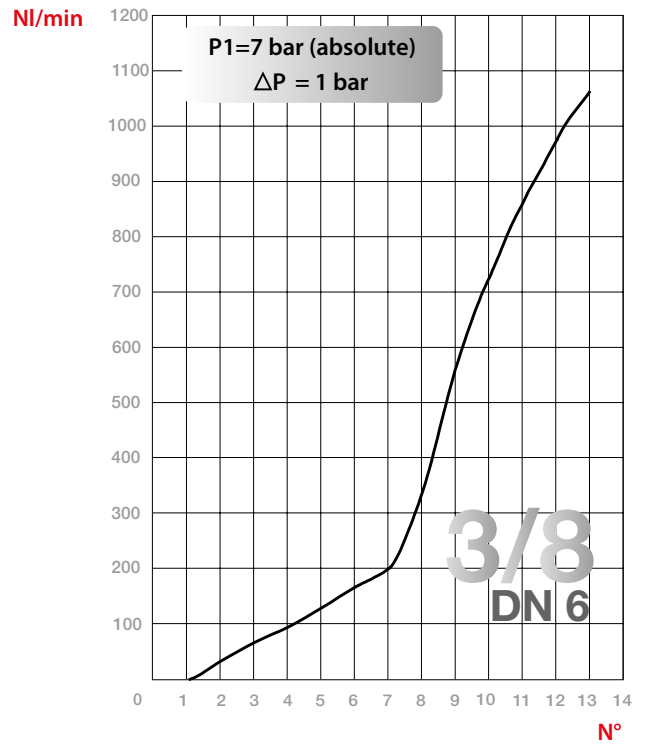
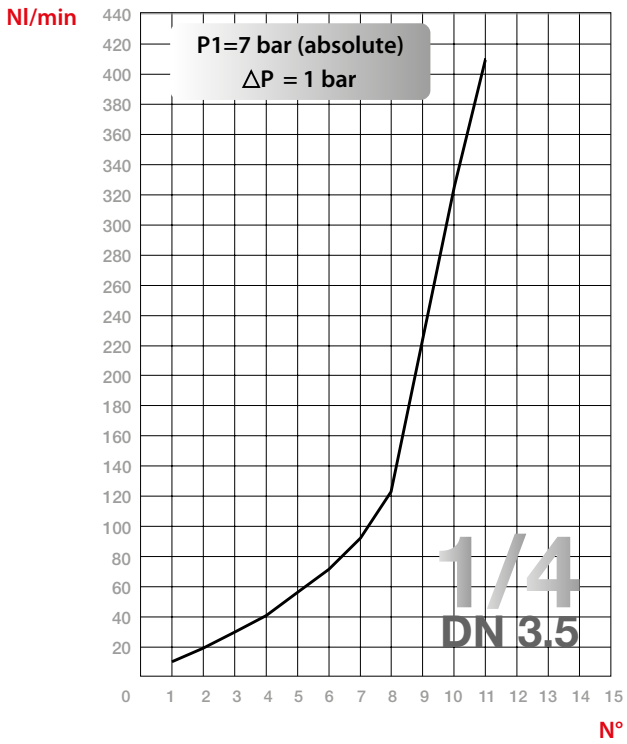

**REGOLATORI DI PORTATA IN LINEA**

IN LINE ADJUSTABLE RESTRICTOR VALVES  
 DURCHFLUSSREGLER FÜR LEITUNGSEINBAU  
 RÉGLEURS DE DÉBIT EN LIGNE  
 REGULADORES DE FLUJO EN LINEA  
 REGULADORAS DE VAZÃO EM LINHA



**CARATTERISTICHE TECNICHE**

TECHNICAL CHARACTERISTICS  
 TECHNISCHE ANGABEN  
 CARACTÉRISTIQUES TECHNIQUES  
 CARACTERÍSTICAS TÉCNICAS  
 CARACTERÍSTICAS TÉCNICAS



**Norma di Riferimento**

- Reference standard
- Entspricht der Norm
- Norme de référence
- Normativa de referencia
- Norma de referência

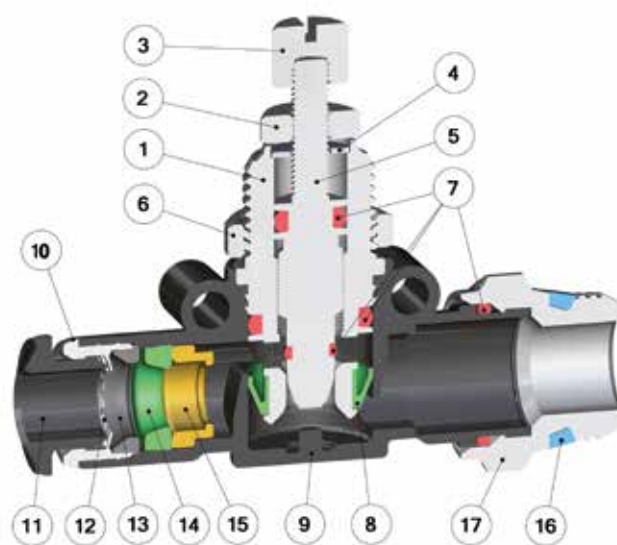

**Materiali e Componenti**

- 1 Nipplo in Ottone Nichelato
- 2 Ghiera di Bloccaggio in Ottone Nichelato
- 3 Pomolo di comando in Ottone Nichelato
- 4 Rondella in acciaio AISI 304
- 5 Spillo di regolazione in Ottone Nichelato
- 6 Ghiera in ottone nichelato
- 7 Guarnizione O-Ring in NBR
- 8 Guarnizione a labbro in NBR
- 9 Corpo in tecnopolimero
- 10 Capsula in ottone nichelato
- 11 Spintore sgancio tubo in resina acetatica
- 12 Pinza d'aggraffaggio in acciaio AISI 301
- 13 Anello di sicurezza in tecnopolimero
- 14 Guarnizione sagomata in NBR
- 15 Supporto guida tubo in ottone
- 16 Guarnizione filetto in NBR
- 17 Basetta in ottone nichelato

IT

**Component Parts and Materials**

- 1 Nickel-Plated Brass Nipple
- 2 Nickel-Plated Brass Locking nut
- 3 Nickel-Plated Brass Adjusting Knob
- 4 Steel AISI 304 Washer
- 5 Nickel-Plated Brass Adjusting needle
- 6 Nickel-plated brass sleeve
- 7 NBR O-Ring seal
- 8 NBR Lip seal
- 9 Technopolymeric Body
- 10 Nickel-Plated Brass Capsule
- 11 Acetalic resin Collet
- 12 Steel AISI 301 Clamping Washer
- 13 Technopolymeric safety Ring
- 14 NBR molded seal
- 15 Brass Tube-guide Support
- 16 NBR Thread Packing
- 17 Nickel-Plated Brass Base

GB

**Komponenten und Materialien**

- 1 Gewindestutzen Messing vernickelt
- 2 Sicherungs-Kontermutter Messing vernickelt
- 3 Einstellknopf Messing vernickelt
- 4 Scheibe Edelstahl AISI 304
- 5 Einstellnadel Messing vernickelt
- 6 Kontermutter Messing vernickelt
- 7 O-Ring NBR
- 8 Lippendichtung NBR
- 9 Körper Technopolymer
- 10 Haltering Messing vernickelt
- 11 Rohr Lösering Acetal
- 12 Zahnscheibe Edelstahl AISI 301
- 13 Sicherungsring Technopolymer
- 14 Lippendichtung NBR
- 15 Rohr Führungshülse Messing
- 16 Gewindedichtung NBR
- 17 Einschraubkörper Messing vernickelt

DE

**Matériaux et Composants**

- 1 Corps fileté: laiton nickelé
- 2 Contre écrou de blocage: laiton nickelé
- 3 Bouton de réglage: laiton nickelé
- 4 Rondelle: acier inoxydable AISI 304
- 5 Vis de réglage: laiton nickelé
- 6 Contre écrou: laiton nickelé
- 7 Joint torique: NBR
- 8 Joint à lèvres: NBR
- 9 Corps: technopolymère
- 10 Capsule de retenue: laiton nickelé
- 11 Poussoir: résine acétal
- 12 Rondelle d'accrochage: AISI 301
- 13 Anneau de sécurité: Technopolymère
- 14 Joint à lèvres: NBR
- 15 Douille de guidage du tube: laiton
- 16 Joint d'étanchéité du filetage: NBR
- 17 Corps fileté: laiton nickelé

FR

**Materiales y Componentes**

- 1 Manguito de unión en latón niquelado
- 2 Tuerca de bloqueo en latón niquelado
- 3 Pomo de mando en latón niquelado
- 4 Arandela en acero AISI 304
- 5 Tornillo de regulación en latón niquelado
- 6 Tuerca en latón niquelado
- 7 Junta tórica O-Ring en NBR
- 8 Junta de labio en NBR
- 9 Cuerpo en tecnopolímero
- 10 Cápsula en latón niquelado
- 11 Anillo de extracción tubo en resina acetálica
- 12 Pinza de sujeción en acero AISI 301
- 13 Anillo de seguridad en tecnopolímero
- 14 Junta de forma en NBR
- 15 Soporte guía tubo en latón
- 16 Junta de forma en NBR
- 17 Base en latón niquelado

ES

**Materiais e Componentes**

- 1 Niple em Latão Niquelado
- 2 Porca de Travamento em Latão Niquelado
- 3 Cabeça de Regulagem em Latão Niquelado
- 4 Arruela em aço AISI 304
- 5 Agulha de regulagem em Latão Niquelado
- 6 Poca em Latão Niquelado
- 7 Vedação O-Ring em NBR
- 8 Vedação em NBR
- 9 Corpo em tecnopolímero
- 10 Cápsula em Latão Niquelado
- 11 Anilha em resina acetálica
- 12 Pinça de travamento em aço AISI 301
- 13 Anel de segurança em tecnopolímero
- 14 Vedação em NBR
- 15 Suporte guia tubo em Latão
- 16 Vedação em NBR
- 17 Base em Latão niquelado

PT

**Pressioni**
*Pressures*
*Druckbereich*
*Pressions*
*Presiones*
*Pressões*
**1 bar** (0.1 MPa)

**10 bar** (1 MPa)

**Temperature**
*Temperatures*
*Temperatur*
*Températures*
*Temperaturas*
*Temperaturas*
**- 20 °C**
**+ 80 °C**

**Fluidi compatibili**
*Aria compressa*
*Fluids*
*Compressed air*
*Geeignete Medien*
*Druckluft*
*Fluides compatibles*
*Air comprimé*
*Fluidos compatibles*
*Aire comprimido*
*Fluidos compatíveis*
*Ar comprimido*

**Tubi di Collegamento**
**IT**
*Tubi in materiale plastico:*
*PA6, PA11, PA12, Polietilene, \*Poliuretano, PTFE, FEP.*
*\*Utilizzo da 90 a 98 Shore, per la massima prestazione è consigliato 98 Shore A.*
**Connection Tubes**
**GB**
*Plastic tubes:*
*PA6, PA11, PA12, Polyethylene, \*Polyurethane, PTFE, FEP.*
*\*Use from 90 to 98 Shore, for maximum performance is recommended 98 Shore A.*
**Geeignete Rohre**
**DE**
*Kunststoffrohre:*
*PA6, PA11, PA 12, Polyethylene, \*Polyurethan, PTFE, FEP.*
*\*Verwenden Sie 90 bis 98 Shore, für maximale Leistung wird 98 Shore A empfohlen.*
**Tubes Conseillés**
**FR**
*Tubes plastiques:*
*PA6, PA11, PA12, Polyéthylène, \*Polyuréthane, PTFE, FEP.*
*\*Utilisation de 90 à 98 Shore, pour une performance maximale recommandée 98 Shore A.*
**Tubos de Conexión**
**ES**
*Tubos en material plástico:*
*PA6, PA11, PA 12, Polietileno, \*Poliuretano, PTFE, FEP.*
*\*Uso de 90 a 98 Shore, para un máximo rendimiento se recomienda 98 Shore A.*
**Tubos de Conexão**
**PT**
*Tubos em material plástico:*
*PA6, PA11, PA12, Polietileno, \*Poliuretano, PTFE, FEP.*
*\*Uso de 90 a 98 Shore, para o desempenho máximo é recomendado 98 Shore A.*

**Filettatura**
**IT**
*Gas conica "UNIVERSAL SHORT".*
**Threads**
**GB**
*"UNIVERSAL SHORT" Tapered thread.*
**Gewindearten**
**DE**
*Konisches Gewinde "UNIVERSAL SHORT".*
**Filetages**
**FR**
*Filetage conique "UNIVERSAL SHORT".*
**Roscas**
**ES**
*Gas cónica "UNIVERSAL SHORT".*
**Roscas**
**PT**
*Gas cónica "UNIVERSAL SHORT".*



**PRINCIPALI CARATTERISTICHE**

*MOST IMPORTANT CHARACTERISTICS*

*WICHTIGSTEN MERKMALE*

*PRINCIPALES CARACTERISTIQUES*

*PRINCIPALES CARACTERÍSTICAS*

*PRINCIPAIS CARACTERÍSTICAS*

**1**

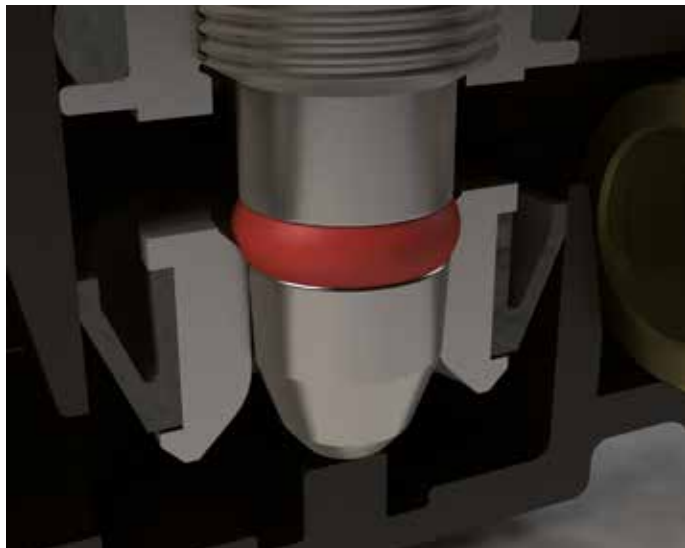

La presenza di un O-ring sullo spillo, migliora la chiusura del regolatore.

*The O-ring on the needle, improve the sealing of the regulator.*

*Durch den O-Ring auf der Einstellnadel kann eine die Schließung zu verbessern.*

*Le joint torique améliorer la étanchéité du réguleur de débit.*

*La presencia de una tórica O-ring en el tornillo, mejorar la estanqueidad del regulador.*

*A presença de um O-ring sob a agulha, melhorar a vedação do regulador.*

**2**



Il montaggio a pannello: è possibile mediante il nipplo filettato e l'apposita ghiera.

*Wall mounting, possible throught the nipple and threaded ring nut.*

*Möglichkeit des Schalttafeleinbaus durch den Gewindestutzen und die Kontermutter.*

*Possibilité de montage en traversée de cloison.*

*El montaje a panel, es posible mediante el manguito roscado y la correspondiente tuerca.*

*A montagem em painel é possível, fazendo-se uso do pescoço roscado e da porca para montagem.*

**3**



E' previsto il montaggio a parete, mediante viti da M3 inserite nelle apposite sedi.

*It provided for wall mounting, with M3 screws inserted into the appropriate locations.*

*Für die Wandmontage kann der Regler mit M3 Schrauben befestigt werden.*

*Montage latéral possible à l'aide de vis M3.*

*Está previsto el montaje a pared, mediante tornillos de M3 introducidos en la correspondiente sede.*

*É prevista a montagem em parede, utilizando-se parafusos M3 nas furações existentes no corpo da reguladora.*

## 55940

### REGOLATORE IN LINEA UNIDIREZIONALE TUBO-TUBO

TUBE IN-LINE NEEDLE VALVE (UNIDIRECTIONAL FLOW)

REGLER FÜR LEITUNGSEINBAU MIT RÜCKSCHLAG ROHR-ROHR

RÉGLEUR DE DÉBIT EN LIGNE, UNI-DIRECTIONNEL

REGULADOR EN LINEA UNIDIRECCIONAL TUBO-TUBO

REGULADORA EM LINHA UNIDIRECCIONAL TUBO-TUBO

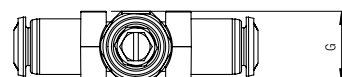
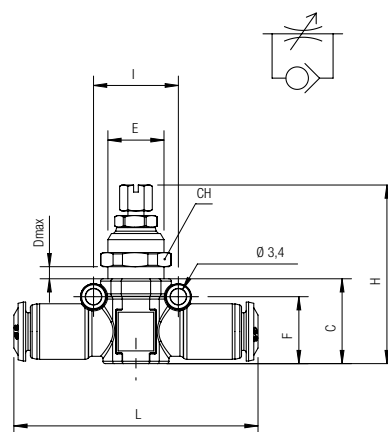

Code	Tube	C	D	E	F	G	H	I	L	CH	Pack.
55940 00 004	4	18	4	M12x1	14.5	15	37.5÷43.5	18	52	14	10
55940 00 001	6	18	6	M12x1	14.5	15	37.5÷43.5	18	52	14	10
55940 00 002	8	20	6.5	M14x1	16.5	17	39.5÷45.5	20	58	16	10
55940 00 003	10	23.5	8	M16x1	19.5	19	47.5÷53.5	22.5	67	18	10

## 55945

### REGOLATORE IN LINEA UNIDIREZIONALE PER CILINDRO MASCHIO "UNIVERSAL SHORT"-TUBO

MALE "UNIVERSAL SHORT"-TUBE IN-LINE FLOW CONTROL (CONTROLLED FLOW OUT)

REGLER FÜR LEITUNGSEINBAU ABLUFTDROSSELUNG GEWINDE "UNIVERSAL SHORT"- ROHR

RÉGLEUR DE DÉBIT EN LIGNE, À L'ÉCHAPPEMENT

REGULADOR EN LINEA UNIDIRECCIONAL PARA CILINDRO MACHO "UNIVERSAL SHORT"- TUBO

REGULADORA EM LINHA ROSCA-TUBO UNIDIRECCIONAL PARA CILINDRO (ROSCA MACHO TIPO "UNIVERSAL SHORT")

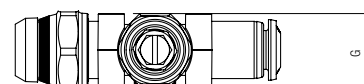
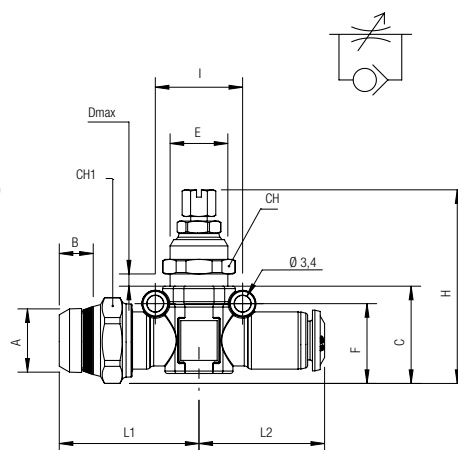

Code	Tube	A	B	C	D	E	F	G	H	I	L1	L2	CH	CH1	Pack.
55945 00 007	4	1/8	5.5	20	6	M12x1	16.5	15	39.5÷45.5	18	28.5	26	14	16	10
55945 00 001	6	1/8	5.5	20	6	M12x1	16.5	15	39.5÷45.5	18	28.5	26	14	16	10
55945 00 002	6	1/4	7	20	6	M12x1	16.5	15	39.5÷45.5	18	28.5	26	14	16	10
55945 00 003	8	1/4	7	23	6.5	M14x1	16.5	17	42.5÷48.5	20	33.5	29	16	20	10
55945 00 004	8	3/8	7.5	23	6.5	M14x1	16.5	17	42.5÷48.5	20	33.5	29	16	20	10
55945 00 005	10	3/8	7.5	24.5	8	M16x1	20.5	19	42.5÷54	22.5	34.5	33.5	18	20	10
55945 00 006	10	1/2	9	25	8	M16x1	21	19	42.5÷54.5	22.5	34.5	33.5	18	21	10

## 55950

### REGOLATORE IN LINEA UNIDIREZIONALE PER VALVOLA TUBO- MASCHIO "UNIVERSAL SHORT"

MALE "UNIVERSAL SHORT"- TUBE IN-LINE FLOW CONTROL (CONTROLLED FLOW IN)

REGLER FÜR LEITUNGSEINBAU ZULUFTDROSSELUNG ROHR-GEWINDE "UNIVERSAL SHORT"

RÉGLEUR DE DÉBIT EN LIGNE, À L'ADMISSION

REGULADOR EN LINEA UNIDIRECCIONAL PARA VÁLVULA TUBO- MACHO "UNIVERSAL SHORT"

REGULADORA EM LINHA ROSCA-TUBO UNIDIRECCIONAL PARA VÁLVULA (ROSCA MACHO TIPO "UNIVERSAL SHORT")

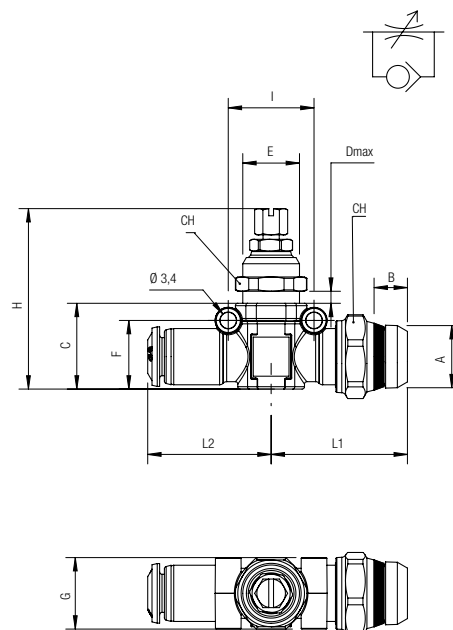

Code	Tube	A	B	C	D	E	F	G	H	I	L1	L2	CH	CH1	Pack.
55950 00 007	4	1/8	5.5	20	6	M12x1	16.5	15	39.5÷45.5	18	29	26	14	16	10
55950 00 001	6	1/8	5.5	20	6	M12x1	16.5	15	39.5÷45.5	18	29	26	14	16	10
55950 00 002	6	1/4	7	20	6	M12x1	16.5	15	39.5÷45.5	18	29	26	14	16	10
55950 00 003	8	1/4	7	23	6.5	M14x1	16.5	17	42.5÷48.5	20	33.5	29	16	20	10
55950 00 004	8	3/8	7.5	23	6.5	M14x1	16.5	17	42.5÷48.5	20	33.5	29	16	20	10
55950 00 005	10	3/8	7.5	24.5	8	M16x1	20.5	19	42.5÷54	22.5	34.5	33.5	18	20	10
55950 00 006	10	1/2	9	25	8	M16x1	21	19	42.5÷54.5	22.5	34.5	33.5	18	21	10

## 55955

### REGOLATORE IN LINEA BIDIREZIONALE TUBO-TUBO

TUBE IN-LINE NEEDLE VALVE (BIDIRECTIONAL FLOW)

REGLER FÜR LEITUNGSEINBAU BI-DIREKTIONAL ROHR-ROHR

RÉGLEUR DE DÉBIT EN LIGNE, BI-DIRECTIONNEL

REGULADOR EN LINEA BIDIRECCIONAL TUBO-TUBO

REGULADORA EM LINHA BI-DIRECCIONAL TUBO-TUBO

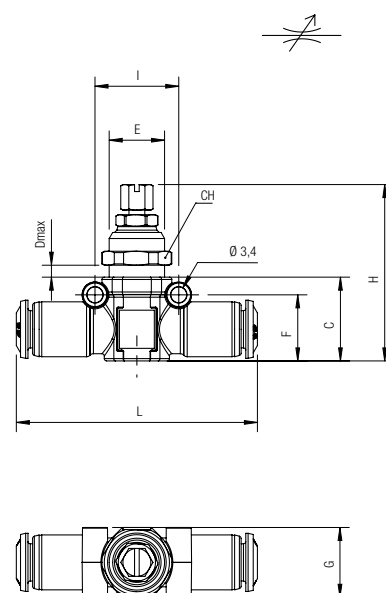

Code	Tube	C	D	E	F	G	H	I	L	CH	Pack.
55955 00 004	4	18	6	M12x1	14.5	15	37.5÷43.5	18	52	14	10
55955 00 001	6	18	6	M12x1	14.5	15	37.5÷43.5	18	52	14	10
55955 00 002	8	20	6.5	M14x1	16.5	17	39.5÷45.5	20	58	16	10
55955 00 003	10	23.5	8	M16x1	19.5	19	47.5÷53.5	22.5	67	18	10

## 55960

### REGOLATORE IN LINEA BIDIREZIONALE MASCHIO "UNIVERSAL SHORT"- TUBO

MALE "UNIVERSAL SHORT" - TUBE IN-LINE FLOW CONTROL (BIDIRECTIONAL FLOW)

REGLER FÜR LEITUNGSSEINBAU BI-DIREKTIONAL GEWINDE "UNIVERSAL SHORT"- ROHR

RÉGLEUR DE DÉBIT EN LIGNE, BI-DIRECTIONNEL "UNIVERSAL SHORT"

REGULADOR EN LINEA BIDIRECCIONAL MACHO "UNIVERSAL SHORT" - TUBO

REGULADORA EM LINHA ROSCA-TUBO BI-DIRECCIONAL PARA CILINDRO (ROSCA MACHO TIPO "UNIVERSAL SHORT")

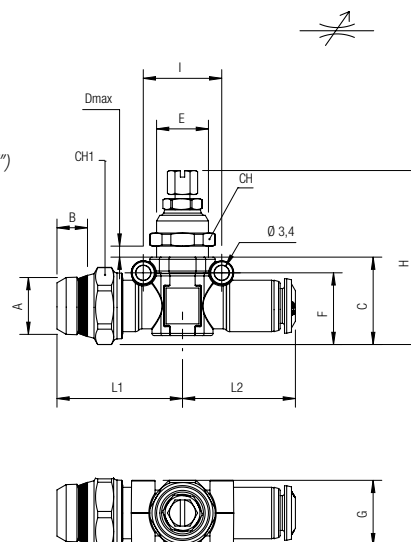

Code	Tube	A	B	C	D	E	F	G	H	I	L1	L2	CH	CH1	Pack.
55960 00 007	4	1/8	5.5	20	6	M12x1	16.5	15	39.5÷45.5	18	28.5	26	14	16	10
55960 00 001	6	1/8	5.5	20	6	M12x1	16.5	15	39.5÷45.5	18	28.5	26	14	16	10
55960 00 002	6	1/4	7	20	6	M12x1	16.5	15	39.5÷45.5	18	28.5	26	14	16	10
55960 00 003	8	1/4	7	23	6.5	M14x1	16.5	17	42.5÷48.5	20	33.5	29	16	20	10
55960 00 004	8	3/8	7.5	23	6.5	M14x1	16.5	17	42.5÷48.5	20	33.5	29	16	20	10
55960 00 005	10	3/8	7.5	24.5	8	M16x1	20.5	19	42.5÷54	22.5	34.5	33.5	18	20	10
55960 00 006	10	1/2	9	25	8	M16x1	21	19	42.5÷54.5	22.5	34.5	33.5	18	21	10

**REGOLATORI DI PRESSIONE IN LINEA**

IN LINE PRESSURE REGULATOR  
 DRUCKREGLER FÜR LEITUNSEINBAU  
 REGULATEUR DE PRESSION EN LIGNE  
 REGULADORES DE PRESIÓN EN LÍNEA  
 REGULADOR DE PRESSÃO EM LINHA



**CARATTERISTICHE TECNICHE**

TECHNICAL CHARACTERISTICS  
 TECHNISCHE ANGABEN  
 CARACTÉRISTIQUES TECHNIQUES  
 CARACTERÍSTICAS TÉCNICAS  
 CARACTERÍSTICAS TÉCNICAS



**Norma di Riferimento**

- Reference standard
- Entspricht der Norm
- Norme de référence
- Normativa de referencia
- Norma de referência

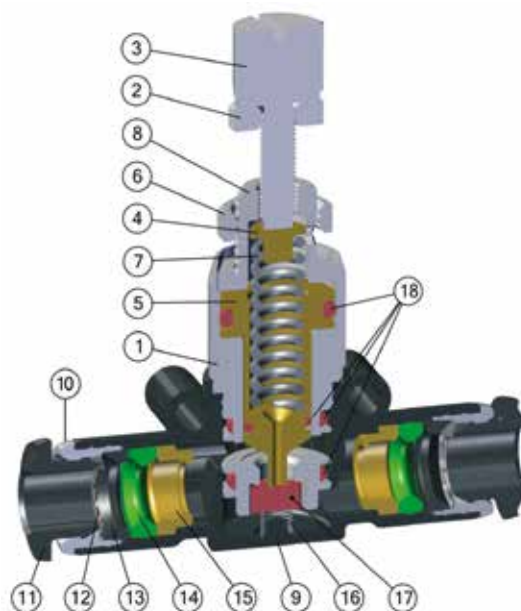

**Materiali e Componenti**

- 1 Nipplo in ottone nichelato
- 2 Ghiera di bloccaggio in ottone nichelato
- 3 Pomolo di comando ottone nichelato
- 4 Supporto molla in ottone
- 5 Spillo in ottone
- 6 Ghiera in ottone nichelato
- 7 Molla spillo in acciaio AISI 631
- 8 Terminale in ottone nichelato
- 9 Corpo in tecnopolimero
- 10 Capsula in ottone nichelato
- 11 Spintore sgancio tubo in resina acetatica
- 12 Pinza d'aggraffaggio in acciaio AISI 301
- 13 Anello di sicurezza in tecnopolimero
- 14 Guarnizione sagomata in NBR
- 15 Supporto guida tubo
- 16 Molla di contrasto
- 17 Guarnizione a fiorellino in NBR
- 18 Guarnizione O-Ring in NBR

**Component Parts and Materials**

- 1 Nickel-Plated Brass Nipple
- 2 Nickel-Plated Brass locking nut
- 3 Nickel-Plated Brass Adjusting Knob
- 4 Spring support in brass
- 5 Brass Adjusting needle
- 6 Nickel-Plated Brass Sleeve
- 7 Spring Adjusting needle in Steel AISI 631
- 8 End part in Nickel-Plated Brass
- 9 Technopolymeric Body
- 10 Nickel-Plated Brass Capsule
- 11 Acetalic resin collet
- 12 Steel AISI 301 Clamping Washer
- 13 Technopolymeric safety ring
- 14 NBR molded Seal
- 15 Brass Tube-Guide Support
- 16 Contrast spring
- 17 Flower seal in NBR
- 18 NBR O-Ring seal

**Komponenten und Materialien**

- 1 Gewindestutzen Messing vernickelt
- 2 Sicherungs-Kontermutter Messing vernickelt
- 3 Einstellknopf Messing vernickelt
- 4 Federhalterung Messing vernickelt
- 5 Einstellnadel Messing vernickelt
- 6 Hülse Messing vernickelt
- 7 Feder Edelstahl AISI 631
- 8 Endring Messing vernickelt
- 9 Körper Technopolymer
- 10 Haltering Messing vernickelt
- 11 Rohr Lösering Acetal
- 12 Zahnscheibe Edelstahl AISI 301
- 13 Sicherungsring Technopolymer
- 14 Lippendichtung NBR
- 15 Rohr Führungshülse Messing
- 16 Einstellfeder
- 17 Ring NBR
- 18 O-Ring NBR

**Matériaux et Composants**

- 1 Corps fileté: laiton nickelé
- 2 Contre écrou de blocage: laiton nickelé
- 3 Bouton de réglage: laiton nickelé
- 4 Support du ressort: laiton
- 5 Vis de réglage: laiton
- 6 Douille: laiton nickelé
- 7 Ressort: acier inoxydable AISI 631
- 8 Capsule: laiton nickelé
- 9 Corps: technopolymère
- 10 Capsule de retenue: laiton nickelé
- 11 Poussoir: résine acétal
- 12 Rondelle d'accrochage: AISI 301
- 13 Anneau de sécurité: technopolymère
- 14 Joint à lèvres: NBR
- 15 Douille de guidage du tube: laiton
- 16 Ressort de contraste
- 17 Bague: NBR
- 18 Joint torique: NBR

**Materiales y Componentes**

- 1 Unión en latón niquelado
- 2 Tuerca de bloqueo en latón niquelado
- 3 Pomo de mando en latón niquelado
- 4 Soporte muelle en latón
- 5 Tornillo en latón
- 6 Tuerca en latón niquelado
- 7 Muelle tornillo en acero AISI 631
- 8 Terminal en latón niquelado
- 9 Cuerpo en tecnopolímero
- 10 Cápsula en latón niquelado
- 11 Anillo de extracción tubo en resina acetálica
- 12 Pinza de sujeción en acero AISI 301
- 13 Anillo de seguridad en tecnopolímero
- 14 Junta de labio en NBR
- 15 Soporte guía tubo
- 16 Muelle de contraste
- 17 Junta en NBR
- 18 Junta O-Ring en NBR

**Materiais e Componentes**

- 1 Niple em latão niquelado
- 2 Porca de travamento em latão niquelado
- 3 Pino de comando latão niquelado
- 4 Suporte da mola em latão
- 5 Agulha em latão
- 6 Porca em latão niquelado
- 7 Mola da agulha em aço AISI 631
- 8 Terminal em latão niquelado
- 9 Corpo em tecnopolimero
- 10 Cápsula em latão niquelado
- 11 Anilha de liberação de tubo em resina acetálica
- 12 Pinça de travamento em aço AISI 301
- 13 Anel de segurança em tecnopolímero
- 14 Vedação tipo lábio em NBR
- 15 Suporte guia tubo
- 16 Mola de contraste
- 17 Vedação da válvula em NBR
- 18 Vedação O-Ring em NBR



### Pressioni di ingresso

Inlet Pressures

Eingangsdruck

Pression d'entrée

Presión de entrada

Pressão de entrada

**2 bar** (0.2 MPa)

**10 bar** (1 MPa)

**Impostare la pressione voluta sempre in salita.**

*Set the pressure always uphill.*

*Gewünschten Druck von 1 bar nach oben einstellen.*

*Le réglage de la pression se fait toujours vers le haut.*

*Ajustar la presión deseada siempre en subida.*

*Regular a pressão desejada sempre na saída.*



### Temperature

Temperatures

Temperatur

Températures

Temperaturas

Temperaturas

**- 20 °C**

**+ 80 °C**



### Fluidi compatibili

Aria compressa

Fluids

Compressed air

Geeignete Medien

Druckluft

Fluides compatibles

Air comprimé

Fluidos compatibles

Aire comprimido

Fluidos compatíveis

Ar comprimido



### Campo di Regolazione

Regulation Range

Regelbereich

Plage de Réglage

Campo de Regulación

Campo de Regulagem

**1 ÷ 8 bar** (0.1 ÷ 0.8 MPa)



### Tubi di Collegamento

Tubi in materiale plastico:

PA6, PA11, PA12, Polietilene, \*Poliuretano, PTFE, FEP.

\*Utilizzo da 90 a 98 Shore, per la massima prestazione è consigliato 98 Shore A.

IT

### Connection Tubes

Plastic tubes:

PA6, PA11, PA12, Polyethylene, \*Polyurethane, PTFE, FEP.

\*Use from 90 to 98 Shore, for maximum performance is recommended 98 Shore A.

GB

### Geeignete Rohre

Kunststoffrohre:

PA6, PA11, PA 12, Polyethylene, \*Polyurethan, PTFE, FEP.

\*Verwenden Sie 90 bis 98 Shore, für maximale Leistung wird 98 Shore A empfohlen.

DE

### Tubes Conseillés

Tubes plastiques:

PA6, PA11, PA12, Polyéthylène, \*Polyuréthane, PTFE, FEP.

\*Utilisation de 90 à 98 Shore, pour une performance maximale recommandée 98 Shore A.

FR

### Tubos de Conexión

Tubos en material plástico:

PA6, PA11, PA 12, Polietileno, \*Poliuretano, PTFE, FEP.

\*Uso de 90 a 98 Shore, para un máximo rendimiento se recomienda 98 Shore A.

ES

### Tubos de Conexão

Tubos em material plástico:

PA6, PA11, PA12, Polietileno, \*Poliuretano, PTFE, FEP.

\*Uso de 90 a 98 Shore, para o desempenho máximo é recomendado 98 Shore A.

PT



### Filettatura

Gas conica "UNIVERSAL SHORT".

IT

### Threads

"UNIVERSAL SHORT" Tapered thread.

GB

### Gewindearten

Konisches Gewinde "UNIVERSAL SHORT".

DE

### Filetages

Filetage conique "UNIVERSAL SHORT".

FR

### Roscas

Gas cónica "UNIVERSAL SHORT".

ES

### Roscas

Gas cónica "UNIVERSAL SHORT".

PT

## 55970

### REGOLATORE DI PRESSIONE IN LINEA TUBO-TUBO

TUBE IN LINE PRESSURE REGULATOR

DRUCKREGLER FÜR LEITUNGSEINBAU

RÉGLEUR DE PRESSION EN LIGNE

REGULADOR DE PRESIÓN EN LÍNEA TUBO - TUBO

REGULADOR DE PRESSÃO EM LINHA TUBO - TUBO

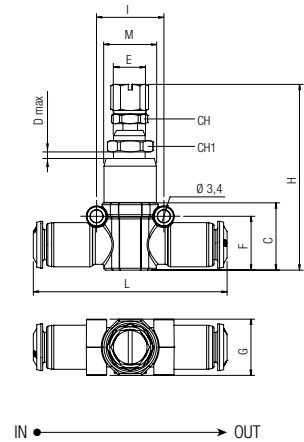
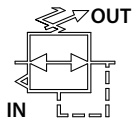

Code	Tube	C	D	E	F	G	H	I	L	M	CH	CH1	Pack.
55970 00 002	6	18	5	M9x1	14.5	15	48÷56.5	18	52	14	9	11	10
55970 00 003	8	20	5	M11x1	16.5	17	55÷65	20	58	17	10	13	10

## 55975

### REGOLATORE DI PRESSIONE IN LINEA TUBO - MASCHIO "UNIVERSAL SHORT"

TUBE - MALE "UNIVERSAL SHORT" IN-LINE PRESSURE REGULATOR

DRUCKREGLER FÜR LEITUNGSEINBAU ROHR - GEWINDE "UNIVERSAL SHORT"

RÉGLEUR DE PRESSION EN LIGNE, TUBE - FILETAGE

REGULADOR DE PRESIÓN EN LÍNEA TUBO - MACHO "UNIVERSAL SHORT"

REGULADOR DE PRESSÃO EM LINHA TUBO - ROSCA MACHO "UNIVERSAL SHORT"

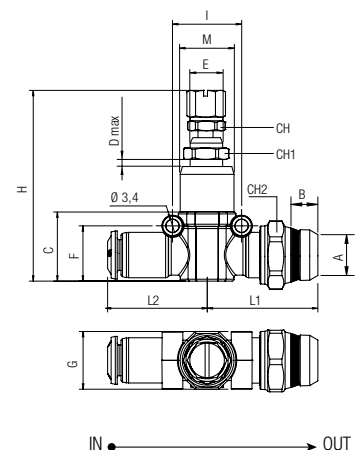
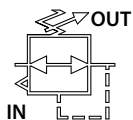

Code	Tube	A	B	C	D	E	F	G	H	I	L1	L2	M	CH	CH1	CH2	Pack.
55975 00 001	6	1/8	5.5	20	5	M9x1	16.5	15	48÷56.5	18	29	26	14	9	11	16	10
55975 00 002	6	1/4	7	20	5	M9x1	16.5	15	48÷56.5	18	29	26	14	9	11	16	10
55975 00 003	8	1/4	7	23	5	M11x1	16.5	17	55÷65	20	33.5	29	17	10	13	20	10
55975 00 004	8	3/8	7.5	23	5	M11x1	16.5	17	55÷65	20	33.5	29	17	10	13	20	10

# 55980

## REGOLATORE DI PRESSIONE IN LINEA MASCHIO "UNIVERSAL SHORT"- TUBO

MALE "UNIVERSAL SHORT" - TUBE IN-LINE PRESSURE REGULATOR

DRUCKREGLER FÜR LEITUNGSEINBAU GEWINDE "UNIVERSAL SHORT" - ROHR

RÉGLEUR DE PRESSION EN LIGNE, FILETAGE - TUBE

REGULADOR DE PRESIÓN EN LÍNEA MACHO "UNIVERSAL SHORT" - TUBO

REGULADOR DE PRESSÃO EM LINHA ROSCA MACHO "UNIVERSAL SHORT" - TUBO

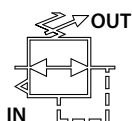
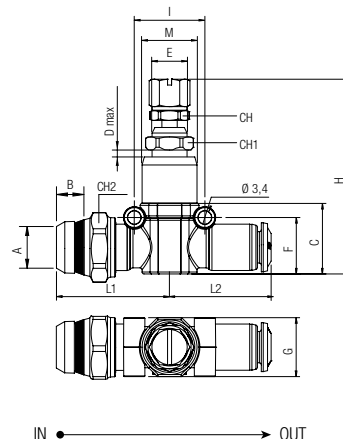

Code	Tube	A	B	C	D	E	F	G	H	I	L1	L2	M	CH	CH1	CH2	Pack.
55980 00 001	6	1/8	5.5	20	5	M9x1	16.5	15	48÷56.5	18	28.5	26	14	9	11	16	10
55980 00 002	6	1/4	7	20	5	M9x1	16.5	15	48÷56.5	18	28.5	26	14	9	11	16	10
55980 00 003	8	1/4	7	23	5	M11x1	16.5	17	55÷65	20	33.5	29	17	10	13	20	10
55980 00 004	8	3/8	7.5	23	5	M11x1	16.5	17	55÷65	20	33.5	29	17	10	13	20	10

## REGOLATORI DI FLUSSO UNIDIREZIONALI

UNI-DIRECTIONAL FLOW REGULATOR  
 DURCHFLUSSREGLER MIT RÜCKSCHLAG  
 REGLEUR EN LIGNE ALUMINIUM UNI-DIRECTIONNEL  
 REGULADORES DE FLUJO UNIDIRECCIONALES  
 REGULADORAS DE VAZÃO UNIDIRECIONAL



### CARATTERISTICHE TECNICHE

TECHNICAL CHARACTERISTICS  
 TECHNISCHE ANGABEN  
 CARACTÉRISTIQUES TECHNIQUES  
 CARACTERÍSTICAS TÉCNICAS  
 CARACTERÍSTICAS TÉCNICAS



### Norma di Riferimento

Reference standard

Entspricht der Norm

Norme de référence

Normativa de referencia

Norma de referência

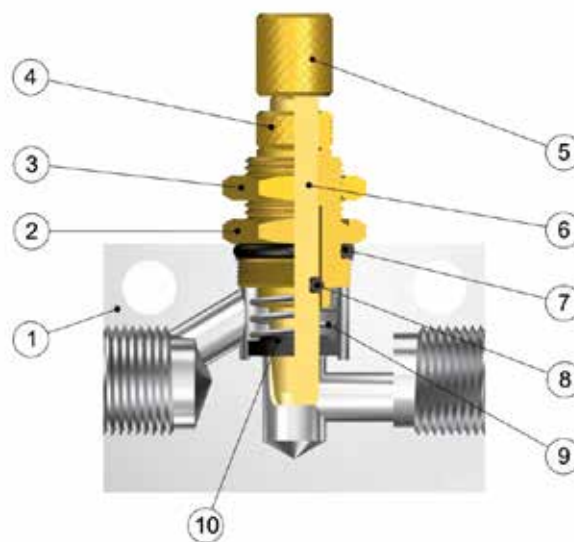

IT	Component Parts and Materials	GB	Komponenten und Materialien	DE
1	Anodized aluminium Body	1	Körper Aluminium eloxiert	
2	Brass Nipple	2	Gewindestutzen Messing	
3	Brass Locking nut	3	Kontermutter Messing	
4	Brass Nut	4	Kontring Messing	
5	Brass Adjusting Knob	5	Einstellknopf Messing	
6	Brass Adjusting needle	6	Stift Messing	
7	NBR O-Ring Nipple	7	Gewindestutzen O-Ring NBR	
8	NBR O-Ring Spillo in NBR	8	Stift O-Ring NBR	
9	Steel Spring	9	Feder Stahl	
10	Seal floating washer	10	Schwimmende Dichtung	

FR	Materiales y Componentes	ES	Materiais e Componentes	PT
1	Cuerpo en aluminio anodizado	1	Corpo in alumínio anodizado	
2	Unión en latón	2	Niple em latão	
3	Tuerca de fijación en latón	3	Porca de fixação em latão	
4	Tuerca en latón	4	Porca em latão	
5	Pomo en latón	5	Cabeça de regulagem em latão	
6	Tornillo regulador en latón	6	Agulha em latão	
7	Junta tórica O-Ring unión en NBR	7	O-Ring do niple em NBR	
8	Junta tórica O-Ring tornillo en NBR	8	O-Ring da agulha em NBR	
9	Muelle en acero	9	Mola em aço	
10	Junta flotante	10	Vedação flutuante	



### Pressioni

Pressures

Druckbereich

Pressions

Presiones

Pressões

**1 bar** (0.1 MPa)

**10 bar** (1 MPa)



### Temperature

Temperatures

Temperatur

Températures

Temperaturas

Temperaturas

**- 20 °C**

**+ 80 °C**



**CARATTERISTICHE DI FLUSSO REGOLATORI DI PORTATA UNIDIREZIONALI E BIDIREZIONALI**

FLOW CHARACTERISTICS ADJUSTABLE RESTRICTOR VALVES UNI-DIRECTIONALS AND BI-DIRECTIONALS

DURCHFLUSSWERTE DER REGLER MIT- ODER OHNE RÜCKSCHLAG

CARACTÉRISTIQUES DES DÉBITS POUR LES RÉGLEURS DE DÉBIT UNI ET BI-DIRECTIONNEL

CARACTERÍSTICAS DE FLUJO REGULADORES DE CAUDAL UNIDIRECCIONALES Y BIDIRECCIONALES

CARACTERÍSTICAS DE VAZÃO REGULADORAS DE VAZÃO UNIDIRECCIONAIS E BI-DIRECCIONAIS

Pressione in entrata Inlet pressure Absoluter Eingangsdruck Pression d'entrée Presión absoluta entrada Pressão de entrada	<b>7 bar</b>
Pressione in uscita: Pressione Atmosferica Outlet pressure: Atmosphere Pressure Absoluter Ausgangsdruck: Atmosphärendruck Pression de sortie: Pression atmosphérique Presión absoluta salida: Presión atmosférica Pressione de saída: Pressão Atmosférica	<b>1013 mbar</b>

**NI/min**  
 Portata d'aria Q a 0° C e 1013 mbar  
 Air rate Q at 0°C and 1013 mbar  
 Luftdurchlass Q bei 0° C und 1013 mbar  
 Débit d'air Q à 0°C et 1013 mbar  
 Caudal de Aire Q 0° C y 1013 mbar  
 Vazão de ar Q 0° C e 1013 mbar

**N°**  
 Numero giri spillo di regolazione  
 Number of turns of the adjusting needle  
 Umdrehungen an der Einstellnadel  
 Nombre de tours de réglage  
 Número de giros tornillo regulador  
 Número de voltas do parafuso de regulagem

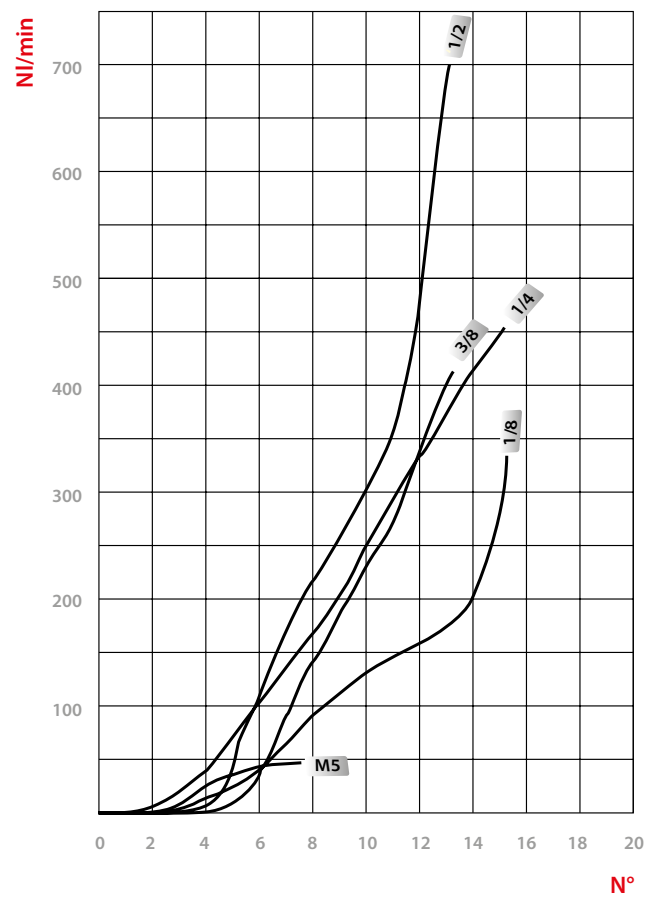

**8850**

**REGOLATORI DI FLUSSO UNIDIREZIONALI**

UNI-DIRECTIONAL FLOW REGULATOR

DURCHFLUSSREGLER MIT RÜCKSCHLAG

RÉGLEUR DE DÉBIT EN LIGNE, UNI-DIRECTIONNEL

REGULADORES DE FLUJO UNIDIRECCIONALES

REGULADORES DE VAZÃO UNIDIRECCIONAL

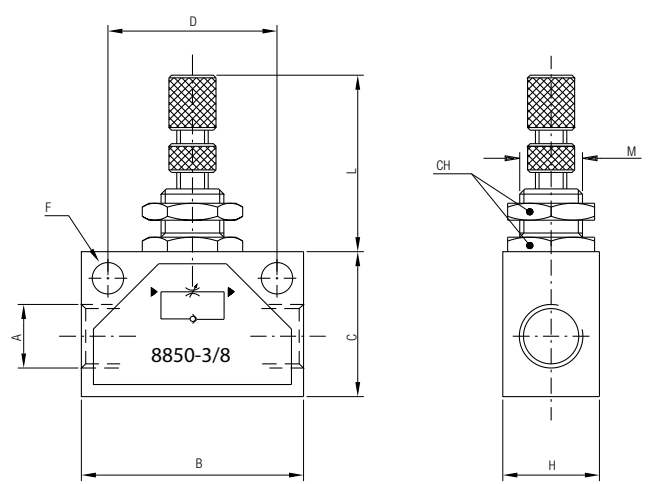

Code	A	B	C	H	D	F	L	M	CH	Pack.
08850 00 001	M5	25	15	12	18	4.5	20-27	M10x0.75	12	10
08850 00 002	1/8	35	22	18	24.7	4.5	26-36	M12x0.75	15	10
08850 00 003	1/4	46	30	20	35	6.5	26-36	M12x0.75	15	10
08850 00 004	3/8	50	30	25	35	6.5	32-42	M18x1.5	22	10
08850 00 005	1/2	60	40	25	44	6.5	32-44	M18x1.5	22	10

## REGOLATORI DI FLUSSO BIDIREZIONALI

BI-DIRECTIONAL FLOW REGULATOR  
 DURCHFLUSSREGLER BI-DIREKTIONAL  
 REGLEUR DE DEBIT EN ALUMINIUM BI-DIRECTIONNEL  
 REGULADORES DE FLUJO BIDIRECCIONALES  
 REGULADORAS DE VAZÃO BI-DIRECIONAL



### CARATTERISTICHE TECNICHE

TECHNICAL CHARACTERISTICS  
 TECHNISCHE ANGABEN  
 CARACTÉRISTIQUES TECHNIQUES  
 CARACTERÍSTICAS TÉCNICAS  
 CARACTERÍSTICAS TÉCNICAS



### Norma di Riferimento

Reference standard

Entspricht der Norm

Norme de référence

Normativa de referencia

Norma de referência

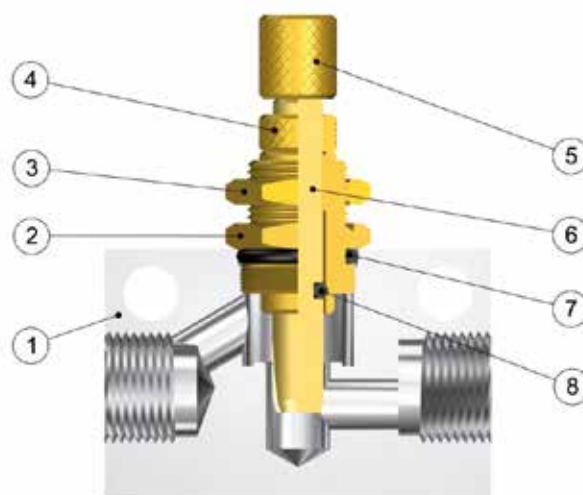

Materiali e Componenti	IT	Component Parts and Materials	GB	Komponenten und Materialien	DE
1 Corpo in alluminio anodizzato		1 Anodized aluminium Body		1 Körper Aluminium eloxiert	
2 Nipplo in ottone		2 Brass Nipple		2 Gewindestutzen Messing	
3 Ghiera di fissaggio in ottone		3 Brass Loking nut		3 Kontermutter Messing	
4 Ghiera in ottone		4 Brass Nut		4 Kontering Messing	
5 Pomolo in ottone		5 Brass Adjusting Knob		5 Einstellknopf Messing	
6 Spillo in ottone		6 Brass Adjusting needle		6 Stift Messing	
7 O-Ring Nipplo in NBR		7 NBR O-Ring Nipple		7 Gewindestutzen O-Ring NBR	
8 O-Ring Spillo in NBR		8 NBR O-Ring Adjusting needle		8 Stift O-Ring NBR	

Matériaux et Composants	FR	Materiales y Componentes	ES	Materiais e Componentes	PT
1 Corps: aluminium anodisé		1 Cuerpo en aluminio anodizado		1 Corpo in alumínio anodizado	
2 Corps fileté: laiton		2 Unión en latón		2 Niple em latão	
3 Contre écrou: laiton		3 Tuerca de fijación en latón		3 Porca de fixação em latão	
4 Ecrou: laiton		4 Tuerca en latón		4 Porca em latão	
5 Bouton de réglage: laiton		5 Pomo en latón		5 Cabeça de regulagem em latão	
6 Vis de réglage: laiton		6 Tornillo regulador en latón		6 Agulha em latão	
7 Joint torique: NBR		7 Junta tórica O-Ring unión en NBR		7 O-Ring do niple em NBR	
8 Joint torique: NBR		8 Junta tórica O-Ring tornillo en NBR		8 O-Ring da agulha em NBR	



### Pressioni

Pressures

Druckbereich

Pressions

Presiones

Pressões

**0 bar** (0 MPa)

**10 bar** (1 MPa)



### Temperature

Temperatures

Temperatur

Températures

Temperaturas

Temperaturas

**- 20 °C**

**+ 80 °C**



**CARATTERISTICHE DI FLUSSO REGOLATORI DI FLUSSO BIDIREZIONALI**

FLOW CHARACTERISTICS ADJUSTABLE RESTRICTOR BI-DIRECTIONAL FLOW REGULATOR  
 DURCHFLOSSWERTE DER REGLER DURCHFLOSSREGLER BI-DIREKTIONAL  
 CARACTÉRISTIQUES DES DÉBITS POUR REGLEUR DE DÉBIT EN ALUMINIUM BI-DIRECTIONNEL  
 CARACTERÍSTICAS DE FLUJO REGULADORES DE FLUJO BIDIRECCIONALES  
 CARACTERÍSTICAS DE VAZÃO REGULADORAS DE VAZÃO BI-DIRECIONAL

Pressione in entrata Inlet pressure Absoluter Eingangsdruck Pression d'entrée Presión absoluta entrada Pressão de entrada	<b>7 bar</b>
Pressione in uscita: Pressione Atmosferica Outlet pressure: Atmosphere Pressure Absoluter Ausgangsdruck: Atmosphärendruck Pression de sortie: Pression atmosphérique Presión absoluta salida: Presión atmosférica Pressione de saída: Pressão Atmosférica	<b>1013 mbar</b>

**Nl/min**  
 Portata d'aria Q a 0° C e 1013 mbar  
 Air rate Q at 0°C and 1013 mbar  
 Luftdurchlass Q bei 0° C und 1013 mbar  
 Débit d'air Q à 0°C et 1013 mbar  
 Caudal de Aire Q 0° C y 1013 mbar  
 Vazão de ar Q 0° C e 1013 mbar

**N°**  
 Numero giri spillo di regolazione  
 Number of turns of the adjusting needle  
 Umdrehungen an der Einstellnadel  
 Nombre de tours de réglage  
 Número de giros tornillo regulador  
 Número de voltas do parafuso de regulagem

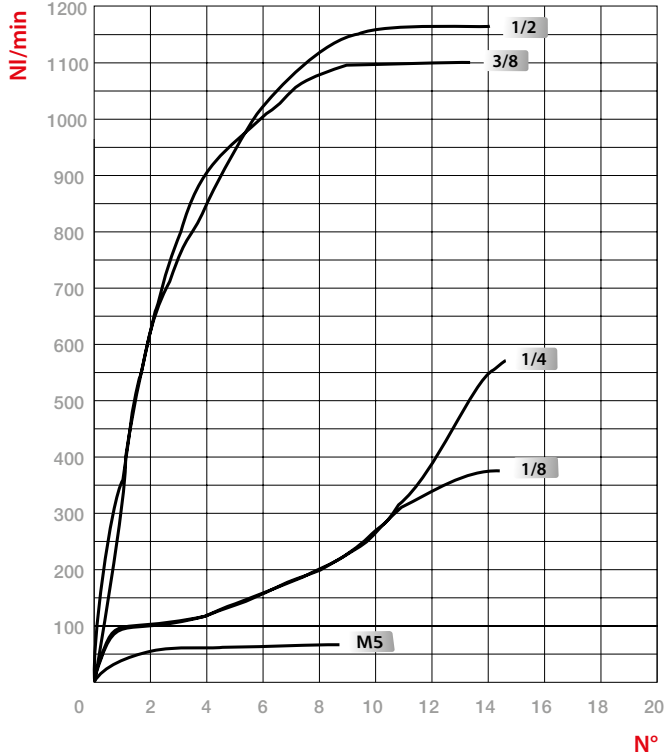

**8860**

**REGOLATORE DI FLUSSO BIDIREZIONALE**  
 BI-DIRECTIONAL FLOW REGULATOR  
 DURCHFLOSSREGLER BI-DIREKTIONAL  
 RÉGLEUR DE DÉBIT EN LIGNE, BI-DIRECTIONNEL  
 REGULADOR DE FLUJO BIDIRECCIONAL  
 REGULADORA DE VAZÃO BI-DIRECIONAL

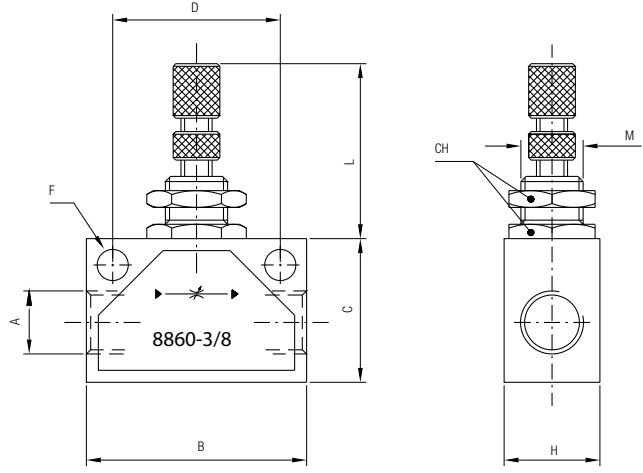

Code	A	B	C	H	D	F	L	M	CH	Pack.
08860 00 001	M5	25	15	12	18	4.5	20-27	M10x0.75	12	10
08860 00 002	1/8	35	22	18	24.7	4.5	27-34	M12x0.75	15	10
08860 00 003	1/4	46	30	20	35	6.5	27-34	M12x0.75	15	10
08860 00 004	3/8	50	30	25	35	6.5	32-43	M18x1.5	22	10
08860 00 005	1/2	60	40	25	44	6.5	32-43	M18x1.5	22	10

**ELEMENTI LOGICI**

LOGIC ELEMENTS  
LOGIKELEMENTE  
SELECTEURS DE CIRCUIT  
ELEMENTOS LÓGICOS  
ELEMENTOS LÓGICOS

**CARATTERISTICHE TECNICHE**

TECHNICAL CHARACTERISTICS  
TECHNISCHE ANGABEN  
CARACTÉRISTIQUES TECHNIQUES  
CARACTERÍSTICAS TÉCNICAS  
CARACTERÍSTICAS TÉCNICAS

**Norma di Riferimento**

Reference standard

Entspricht der Norm

Norme de référence

Normativa de referencia

Norma de referência

1907/2006

REACH ✓

2011/65/CE

RoHS ✓

PED  
2014/68/EU

SILICON  
FREE

Materiali	IT	Materials	GB	Materialien	DE
1 Corpo in alluminio anodizzato		1 Anodised aluminium body		1 Körper aus aluminium eloxiert	
2 Molla in INOX		2 Stainless steel springs		2 Seegerring aus INOX	
3 Guarnizioni in NBR		3 NBR seals		3 Dichtung aus NBR	
4 Parti interne in ottone		4 Internal parts in brass		4 Interne koponenten aus messing	
Matériaux	FR	Materiales	ES	Materiais	PT
1 Corps en aluminium anodisé		1 Cuerpo en aluminio anodizado		1 Corpo em alumínio anodizado	
2 Ressort en INOX		2 Muelle en INOX		2 Mola em INOX	
3 Joints en NBR		3 Juntas NBR		3 Vedações em NBR	
4 Composants internes en laiton		4 Parte interna en latón		4 Partes internas em latão	

**Pressione di funzionamento**

Operating pressure

Druckbereich

Pressions

Presión de Trabajo

Pressão de Trabalho

**2 bar** (0.2 MPa)

**10 bar** (1 MPa)

**Temperatura di funzionamento**

Operating temperature

Temperatur

Température

Temperatura de Trabajo

Temperatura de Trabalho

**- 10 °C**

**+ 60 °C**

**Fluidi**

Aria compressa

Fluids

Compressed air

Medien

Druckluft

Fluides

Air comprimé

Fluidos

Aire comprimido

Fluidos

Ar comprimido

**Attacco filettato**

Threaded

Gewinde

Filetages

Rosca

Conexão Roscada

**1/8**

**Portata nominale (6 bar)**

Flow rate (6 bar)

Nenndurchfluss (6 bar)

Débit (6 bar)

Caudal nominal (6 bar)

Vazão nominal (6 bar)

**100 NI/min**

# 8870

## VALVOLA SELETRICE CON FUNZIONE "OR"

IN-LINE "OR" LOGIC ELEMENT  
 FUNKTIONSELEMENT "ODER"  
 SELECTEUR FONCTION "OU"  
 VÁLVULA SELECTORA FUNCIÓN "OR"  
 VÁLVULA SELETORA COM FUNÇÃO "OU"

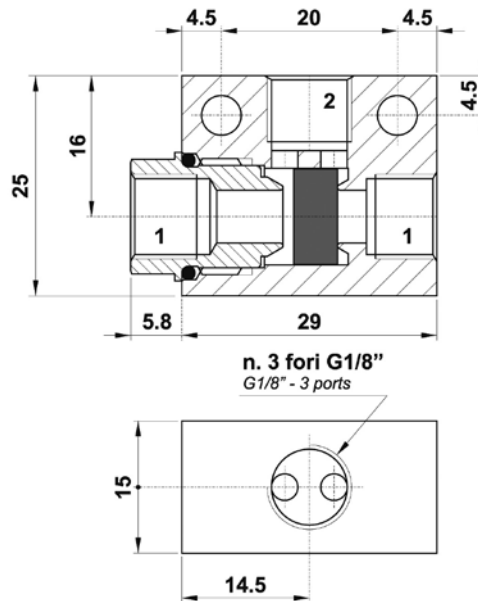
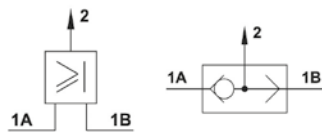

Code	Size	Function	DN	Pack.
08870 00 001	1/8	OR	4	1

# 8872

## VALVOLA SELETRICE CON FUNZIONE "AND"

IN-LINE "AND" LOGIC ELEMENT  
 FUNKTIONSELEMENT "UND"  
 SELECTEUR FONCTION "ET"  
 VÁLVULA SELECTORA FUNCIÓN "AND"  
 VÁLVULA SELETORA COM FUNÇÃO "E"

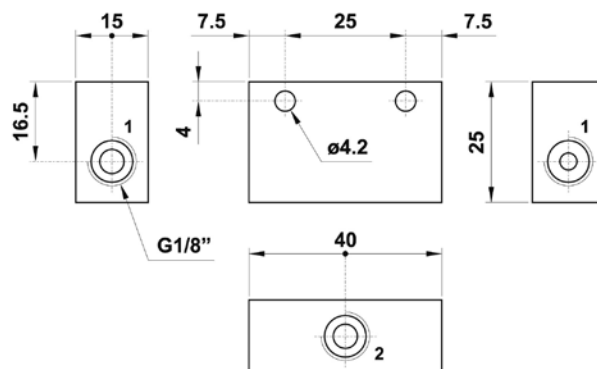
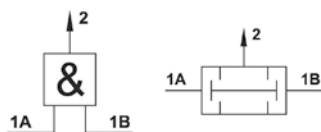

Code	Size	Function	DN	Pack.
08872 00 001	1/8	AND	3	1

# 8875

## NEBULIZZATORE A DEPRESSIONE

VACUUM DRIVEN LIQUID SPRAYER

VAKUUMBETRIEBENER FLÜSSIGKEITSZERSTÄUBER

PULVÉRISATEUR À DÉPRESSION

NEBULIZADOR DE VACÍO

AGULHETA DE PULVERIZAÇÃO A VÁCUO

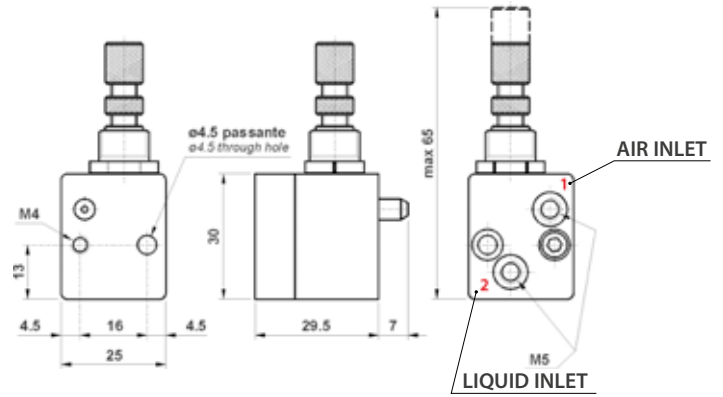

Code	Size	Pack.
08875 00 001	M5	1

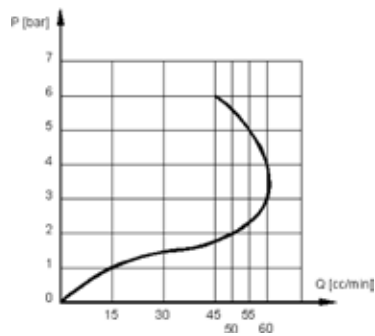

	min	max
<b>Temperature</b>		+ 60 °C
<b>Pressure</b>	3 bar	8 bar
<b>Viscosity of liquid</b>	3° Engler	5° Engler
<b>Soglia di filtrazione - Filtration threshold - Filterfeinheit</b> <i>Capacité de filtration - Grado de filtración - Limite de filtragem</i>		50 µm

**VALVOLE A SCARICO RAPIDO**

QUICK EXHAUST VALVE  
SCHNELLENTLÜFTUNGSVENTILE  
VANNE À PURGE RAPIDE  
VÁLVULA DE ESCAPE RÁPIDO  
VÁLVULA ESCAPE RÁPIDO



**CARATTERISTICHE TECNICHE**

TECHNICAL CHARACTERISTICS  
TECHNISCHE ANGABEN  
CARACTÉRISTIQUES TECHNIQUES  
CARACTERÍSTICAS TÉCNICAS  
CARACTERÍSTICAS TÉCNICAS



**Norma di Riferimento**

Reference standard  
Entspricht der Norm  
Norme de référence  
Normativa de referencia  
Norma de referência

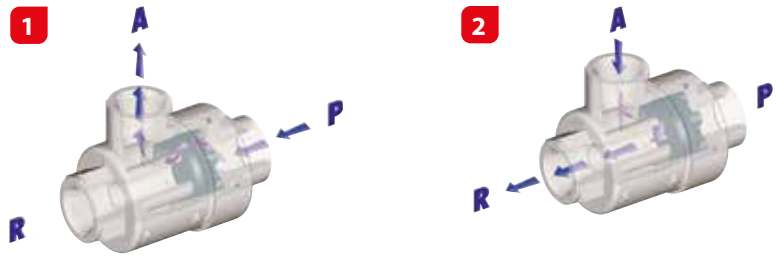

**Materiali e Componenti** **IT** **Component Parts and Materials** **GB** **Komponenten und Materialien** **DE**

1 Corpo in Ottone nichelato	1 Nickel-plated Brass Body	1 Körper Messing vernickelt
2 Guarnizione piatta in PA66	2 PA66 Flat Seals	2 O-Ring PA66
3 Coperchio in ottone nichelato	3 Nickel-plated Brass Cover cap	3 Abdeckung Messing vernickelt
4 Tampone in NBR	4 NBR Pad	4 Membrane NBR

**Matériaux et Composants** **FR** **Materiales y Componentes** **ES** **Materiais e Componentes** **PT**

1 Corps: laiton nickelé	1 Cuerpo en latón niquelado	1 Corpo em Latão Niquelado
2 Joint torique: PA66	2 Junta tórica O-Ring en Nylon PA66	2 Vedação O-Ring em PA66
3 Couvercle: laiton nickelé	3 Tapa en latón niquelado	3 Cobertura em Latão Niquelado
4 Clapet: NBR	4 Membrana en NBR	4 Tampão em NBR



**Pressioni**

Pressures  
Druckbereich  
Pressions  
Presiones  
Pressões

**0.3 bar** (0.03 MPa)  
**10 bar** (1 MPa)



**Temperature**

Temperatures  
Temperatur  
Temperatures  
Temperaturas  
Temperaturas

**- 20 °C**  
**+ 80 °C**

IT	GB	DE
<p>Nella norma UNI ISO 5598 questo articolo viene così definito: "Valvola la cui uscita viene immediatamente aperta a scarico ogni qualvolta cala il valore di pressione dell'aria all'ingresso". L'aria proveniente dall'impianto entra da P sposta il tampono escludendo lo scarico R e va all'utilizzo A (Fig. 1). Nel momento in cui viene a mancare la pressione all'ingresso P, l'aria che si trova all'utilizzo per differenza di pressione sposta il tampono escludendo P e fuoriesce dallo scarico R (Fig. 2). Queste valvole permettono quindi una maggiore rapidità di scarico velocizzando i cicli di lavoro. All'uscita di R è sempre consigliabile mettere un silenziatore, oppure con opportuni collegamenti si può riutilizzare il flusso per ulteriori segnali o utilizzi.</p>	<p>According to the definition of the UNI standards ref. UNI-ISO 5598 this valve is considered: "Valve which immediately opens its outlet to exhaust, whenever the pressure of the air decreases at the inlet." The air arrives from the system and enters at "P", it moves the pad sealing "R" and bending the pad edges, it travels to "A" (Fig. 1). When it miss the pressure in "P", the air presents into the system due to the difference of pressure, it moves the pad sealing "P" and it clears through outlet "R" (Fig 2). This allows a speedy and a better exhaust and also it speeds up the work cycles. At the outlet "R" it is advised to assembly a silencer or if necessary use the flow for further signals or uses.</p>	<p>Die UNI ISO 5598 Norm dieses Artikels ist wie folgt definiert: "Ventil, dessen Ausgang sich zum Entlüften sofort öffnet, sobald sich der Luftdruck am Eingang reduziert". Die Druckluft kommt aus der Druckluftleitung vom Eingang P, bewegt die Pufferdichtung und dichtet den Ausgang R ab und somit strömt die Druckluft zum Verbraucher über den Ausgang A (Fig. 1). Im Moment wo die Druckluftzufuhr vom Eingang P unterbrochen wird, wird die Pufferdichtung wieder in die Ausgangsposition zurückbewegt und dichtet den Eingang P ab (durch die dabei entstehende Druckdifferenz) und somit kann die Druckluft vom Ausgang A über Ausgang R entlüften (Fig. 2). Diese Ventile ermöglichen durch die schnellere Entlüftung die Arbeitszyklen zu erhöhen. Beim Ausgang R ist es immer ratsam einen Schalldämpfer einzusetzen oder die ausgehende Druckluft kann als Signal oder für anderen Nutzen verwendet werden.</p>

FR	ES	PT
<p>La norme UNI EN ISO 5598 définit cet article comme suit: «La vanne s'ouvre immédiatement, lorsque la pression de l'air diminue à l'entrée». L'air arrive dans le système par l'orifice "P", il déplace le clapet d'étanchéité vers "R" et alimente l'orifice "A" (Fig 1). Lorsque la pression "P" diminue le clapet se déplace de "R" à "P" en raison de la différence de pression du système et met l'orifice "A" à l'échappement sur l'orifice "R" (Fig. 2). Cette vanne permet de purger rapidement un système et ainsi d'augmenter le nombre de cycle de travail. Sur la sortie de purge "R", il est conseillé de monter un silencieux d'échappement ou si nécessaire, d'utiliser le flux d'air comme signal ou autres applications.</p>	<p>En la norma UNI ISO 5598 este artículo viene así definido: "Válvula que la salida de la misma viene inmediatamente abierta a escape cada vez que cae la presión del aire a la entrada." El aire proveniente de la instalación entra por P desplaza la membrana excluyendo el escape R y va a la salida A (Fig. 1). En el momento en que no hay presión a la entrada P, el aire que se encuentra en la salida por diferencia de presión desplaza la membrana excluyendo P y sale por el escape R (Fig. 2). Estas válvulas permiten una mayor rapidez de escape agilizando los ciclos de trabajo. A la salida R es siempre conveniente montar un silenciador, o también con oportunas conexiones se puede reutilizar el flujo para otras señales o utilizations.</p>	<p>Na norma UNI ISO 5598 este item vem definido da seguinte forma: "Válvula que imediatamente abre sua saída à exaustão sempre que a pressão do ar de entrada caia". O ar proveniente da rede de ar entra na conexão "P", movimentando o tampão (item 3) vedando o escape "R" da válvula e sai pela conexão de utilização "A" (Fig. 1). No momento em que a pressão cai na entrada "P" da válvulae all'ingresso P, o ar que se encontra em utilização retorna devido a diferença de pressão e movimentando o tampão fechando a entrada "P" e abrindo a passagem do escape "R" (Fig. 2). Estas válvulas permitem desta forma uma maior rapidez de escape aumentando a tornando mais velozes os ciclos de trabalho. Na saída de "R" é sempre aconselhável a utilização de um silenciador ou se necessário utilizar este fluxo para sinalizações ou outros usos.</p>

**Fluidi compatibili**  
Aria compressa

**Fluids**  
Compressed air

**Geeignete Medien**  
Druckluft

**Fluides compatibles**  
Air comprimé

**Fluidos compatibles**  
Aire comprimido

**Fluidos compatíveis**  
Ar comprimido

**ATTENTION!**

**Lo scarico in ambiente esclude l' utilizzo della valvola con gas tossici, corrosivi, infiammabili.**  
The free exhaust to atmosphere do not allow to use the valve with toxic, corrosives and inflammables gas.  
Durch das entweichen in die umwelt ist der einsatz mit giftigen, ätzenden oder entzündbaren gasen verboten.  
L'échappement libre dans l'atmosphère ne permet pas d'utiliser ces vannes avec des gazes toxiques, corrosives et inflammables .  
El escape a atmosfera excluye el uso de la válvula con gases toxicos, corrosivos o inflamables.  
No caso de escape para a atmosfera não é permitida a utilização desta válvula com gases tóxicos, corrosivos e inflamáveis.



Filettatura	IT	Threads	GB	Gewindearten	DE
Gas cilindrica conforme ISO 228. Metrica conforme ISO R/262.		Parallel gas in conformity with ISO 228. Metric in conformity with ISO R/262.		Zylindrisches Gewinde nach Norm ISO 228. Metrisches Gewinde nach Norm ISO R/262.	
Filetages	FR	Roscas	ES	Roscas	PT
Filetage cylindrique conforme ISO 228. Filetage métrique conforme: ISO R/262.		Gas cilindrica conforme ISO 228. Métrica conforme ISO R/262.		Gas paralela conforme ISO 228. Métrica conforme ISO R/262.	

## 6050

### VALVOLA A SCARICO RAPIDO

QUICK EXHAUST VALVE  
SCHNELLENTLÜFTUNGSVENTILE  
VANNE À PURGE RAPIDE  
VÁLVULA DE ESCAPE RÁPIDO  
VÁLVULA DE ESCAPE RÁPIDO

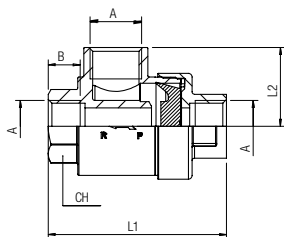

Code	A	B	L1	L2	CH	Pack.
06050 00 001	M5	4	25	10	17	10
06050 00 002	1/8	8.5	37	18.5	14	10
06050 00 003	1/4	11	45.7	23.5	17	10
06050 00 004	3/8	12	60.5	26.5	22	10
06050 00 005	1/2	15	72	32	26	10
06050 00 006	3/4	18.5	88	37	32	5
06050 00 007	1"	19	109	48	46	1

## 6052

### TAMPONE PER VALVOLA A SCARICO RAPIDO IN NBR

PAD FOR QUICK EXHAUST VALVE MADE IN NBR  
MEMBRANE NBR FÜR SCHNELLENTLÜFTUNGSVENTILE  
MEMBRANE NBR POUR PURGE RAPIDE  
MEMBRANA PARA VÁLVULA DE ESCAPE RÁPIDO EN NBR  
TAMPÃO PARA VÁLVULA DE ESCAPE RÁPIDO EM NBR

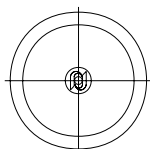

Code	Size	Pack.
06052 00 29 B5 00	M5	20
06052 00 29 02 00	1/8	20
06052 00 29 03 00	1/4	20
06052 00 29 04 00	3/8	10
06052 00 29 05 00	1/2	10
06052 00 29 07 00	3/4	5
06052 00 29 09 00	1"	5

	min	max
Temperature	- 20 °C	+ 80 °C

## 6052

### TAMPONE PER VALVOLA A SCARICO RAPIDO IN POLIURETANO

PAD FOR QUICK EXHAUST VALVE MADE IN POLYURETHANE  
MEMBRANE POLYURETHAN FÜR SCHNELLENTLÜFTUNGSVENTILE  
MEMBRANE EN POLYURETHANE POUR PURGE RAPIDE  
MEMBRANA PARA VÁLVULA DE ESCAPE RÁPIDO EN POLIURETANO  
TAMPÃO PARA VÁLVULA DE ESCAPE RÁPIDO EM POLIURETANO

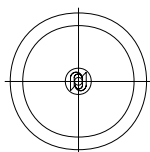

Code	Size	Pack.
06052 00 35 02 00	1/8	20
06052 00 35 03 00	1/4	20
06052 00 35 05 00	1/2	10
06052 00 35 07 00	3/4	5

	min	max
Temperature	- 30 °C	+ 100 °C

## 6053

### GUARNIZIONE COPERCHIO

CAP SEAL  
ABDECKUNGSDICHTUNG  
JOINT POUR COUVERCLE  
JUNTA TAPA  
VEDAÇÃO DA COBERTURA

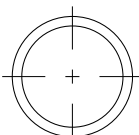
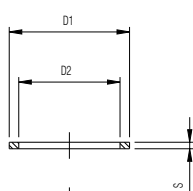

Code	Size	D1	D2	S	Pack.
06053 00 25 B5 00	M5	15.8	13	1	20
06053 00 25 02 00	1/8	24	20.2	1.3	20
06053 00 25 03 00	1/4	29	25.4	1.5	20
06053 00 25 04 00	3/8	33.5	28	1.5	10
06053 00 25 05 00	1/2	38.8	32	1.5	10
06053 00 25 07 00	3/4	43	38	1.5	5
06053 00 25 09 00	1"	69.5	58.2	4.2	5

**VALVOLE A CORSOIO**

SLIDE VALVE  
HANDSCHIEBEVENTILE  
VANNE COULISSANTE  
VÁLVULAS DE CORREDERA  
VÁLVULAS DESLIZANTES



**CARATTERISTICHE TECNICHE**

TECHNICAL CHARACTERISTICS  
TECHNISCHE ANGABEN  
CARACTÉRISTIQUES TECHNIQUES  
CARACTERÍSTICAS TÉCNICAS  
CARACTERÍSTICAS TÉCNICAS



**Norma di Riferimento**

Reference standard

Entspricht der Norm

Norme de référence

Normativa de referencia

Norma de referência

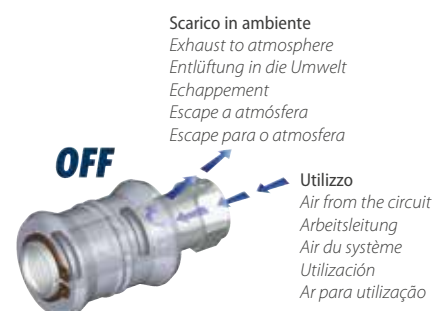

**Materiali e Componenti**

- 1 Manicotto in Alluminio anodizzato
- 2 Stelo in Ottone cromato
- 3 Guarnizione O-Ring in NBR
- 4 Seeger in acciaio

IT

**Component Parts and Materials**

- 1 Grey anodized Aluminium Sleeve
- 2 Chrome-Nickel plated Brass Stem
- 3 NBR O-RING Seals
- 4 Steel Seeger

GB

**Komponenten und Materialien**

- 1 Schieberhülse Aluminium eloxiert
- 2 Gehäuse Messing verchromt
- 3 O-Ring NBR
- 4 Seegering Stahl

DE

**Matériaux et Composants**

- 1 Manchon coulissant: aluminium anodisé
- 2 Corps: laiton chromé
- 3 Joint torique: NBR
- 4 Circlips: acier

FR

**Materiales y Componentes**

- 1 Corredera en aluminio anodizado
- 2 Eje en latón cromado
- 3 Junta tórica O-Ring en NBR
- 4 Seeger en acero

ES



**Materiais e Componentes**

- 1 Manopla em Alumínio anodizado
- 2 Haste me Latão cromado
- 3 Vedação O-Ring em NBR
- 4 Anel de retenção seeger em aço

PT

IT	GB	DE
<p>Le valvole a corsoio possono essere considerate valvole di intercettazione ON-OFF con la variante che in posizione di chiuso lasciano defluire l'aria dell'utilizzo in ambiente, scaricando quindi la pressione nell'impianto a valle.</p> <p>Nella posizione ON l'aria proveniente dall'impianto si convoglia verso l'utilizzo attraverso il collegamento dei fori radiali sullo stelo della valvola.</p> <p>Spostando il manicotto in posizione OFF si esclude il collegamento tra impianto e utilizzo e l'aria che si trova in quest'ultimo, defluisce automaticamente in ambiente per differenza di pressione.</p>	<p><i>The slide valve can be considered a reversing valves ON-OFF with the variant that in the closed position it allows the used air to flow out to atmosphere.</i></p> <p><i>More detailed: in the opened position the air which comes from the system directs itself towards the circuit across the connection of the radial holes on the stem of the valve.</i></p> <p><i>Throwing the sleeve in the closed position You leave out the connection of the radial holes and the air which is still in the circuit due to the difference of pressure with the atmosphere, flows out automatically.</i></p>	<p><i>Das Handschiebeventil kann als ein ON-OFF Absperrventil verwendet werden, mit dem Unterschied, dass die gebrauchte Luft in der geschlossenen Positionen entlüftet werden kann.</i></p> <p><i>D.h. in der geöffneten Stellung fließt die Luft, welche vom System kommt, selbstständig durch den Anschluss in den Kreislauf.</i></p> <p><i>Wenn Sie die Hülse in Schliessposition schieben, entweicht die im Kreislauf verbliebene Luft automatisch durch die Bohrungen in die Umwelt.</i></p>

FR	ES	PT
<p><i>La vanne coulissante peut être considérée comme une vanne ON-OFF avec en position fermée une purge du système en aval.</i></p> <p><i>En position ouverte les orifices latéraux sont fermés par le manchon coulissant et l'air circule au travers de la vanne.</i></p> <p><i>En faisant coulisser le manchon (position fermée), l'alimentation est coupée. L'air situé en aval est libéré dans l'environnement à travers les orifices latéraux (purge de machine).</i></p>	<p><i>Las válvulas de corredera se pueden considerar válvulas de paso ON-OFF con la variante que en la posición OFF dejan fluir el aire de la utilización al ambiente, descargando la presión del circuito.</i></p> <p><i>En la posición ON el aire proveniente del circuito pasa a la utilización a través de la conexión de los taladros radiales del eje de la válvula.</i></p> <p><i>Desplazando la válvula en posición OFF se cierra la conexión entre circuito y utilización, y el aire que se encuentra en la utilización fluye automáticamente al ambiente por diferencia de presión.</i></p>	<p><i>As válvulas deslizantes podem ser consideradas válvulas de intercepção ON-OFF com a variante que em posição fechada, despressurizam o sistema, descarregando desta forma a pressão à sua frente.</i></p> <p><i>Com a manopla na posição ON o ar proveniente de rede atinge a utilização através dos furos radiais existentes na válvula.</i></p> <p><i>Colocando-se a manopla na posição "OFF" a entrada de ar pelos furos radiais é fechada e, desta forma a pressão em utilização retorna por diferença de pressão e é descarregada para a atmosfera por dentro da manopla.</i></p>

 <p><b>Pressioni</b></p> <p>Pressures</p> <p>Druckbereich</p> <p>Pressions</p> <p>Presiones</p> <p>Pressões</p> <p><b>-0.99 bar</b> (0.099 MPa)</p> <p><b>10 bar</b> (1.0 MPa)</p>	 <p><b>Temperature</b></p> <p>Temperatures</p> <p>Temperatur</p> <p>Températures</p> <p>Temperaturas</p> <p>Temperaturas</p> <p><b>- 20 °C</b></p> <p><b>+ 80 °C</b></p>	 <p><b>Fluidi compatibili</b></p> <p>Aria compressa</p> <p>Fluids</p> <p>Compressed air</p> <p>Geeignete Medien</p> <p>Druckluft</p> <p>Fluides compatibles</p> <p>Aire comprimé</p> <p>Fluidos compatibles</p> <p>Aire comprimido</p> <p>Fluidos compatíveis</p> <p>Ar comprimido</p>
----------------------------------------------------------------------------------------------------------------------------------------------------------------------------------------------------------------------------------------------------------------------	-------------------------------------------------------------------------------------------------------------------------------------------------------------------------------------------------------------------------------------------------------------	-----------------------------------------------------------------------------------------------------------------------------------------------------------------------------------------------------------------------------------------------------------------------------------------------------------------------------------------------------------------------------

 <p><b>Filettatura</b></p> <p>Gas cilindrica conforme ISO 228.</p>	<p><b>Threads</b></p> <p>Parallel gas in conformity with ISO 228.</p>	<p><b>Gewindearten</b></p> <p>Zylindrisches Gewinde nach Norm ISO 228.</p>
<p><b>Filetages</b></p> <p>Filetage cylindrique conforme ISO 228.</p>	<p><b>Roscas</b></p> <p>Gas cilíndrica conforme ISO 228.</p>	<p><b>Roscas</b></p> <p>Gas paralela conforme ISO 228.</p>

**6060**

**VALVOLA A CORSOIO**

SLIDE VALVE  
HANDSCHIEBEVENTILE  
VANNE COULISSANTE  
VÁLVULA DE CORREDERA  
VÁLVULA DESLIZANTE

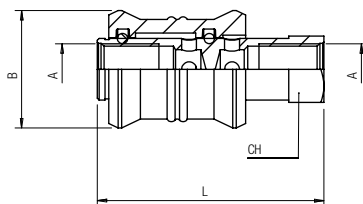

Code	A	Colour	B	L	CH	Pack.
06060 00 001	1/8	Grey	25	48	14	10
06060 00 002	1/4	Grey	30	58	17	10
06060 00 003	3/8	Grey	35	70	22	5
06060 00 004	1/2	Grey	40	80	26	5
06060 00 R01	1/8	Red	25	48	14	10
06060 00 R02	1/4	Red	30	58	17	10
06060 00 R03	3/8	Red	35	70	22	5
06060 00 R04	1/2	Red	40	80	26	5
06060 00 B01	1/8	Blue	25	48	14	10
06060 00 B02	1/4	Blue	30	58	17	10
06060 00 B03	3/8	Blue	35	70	22	5
06060 00 B04	1/2	Blue	40	80	26	5

## VALVOLE UNIDIREZIONALI O DI NON RITORNO

UNIDIRECTIONAL VALVES OR NON RETURN VALVES  
RÜCKSCHLAGVENTILE  
CLAPET ANTI-RETOUR  
VÁLVULAS UNIDIRECCIONALES O ANTIRETORNO  
VÁLVULAS UNIDIRECIONAIS OU ANTI-RETORNO



### CARATTERISTICHE TECNICHE

TECHNICAL CHARACTERISTICS  
TECHNISCHE ANGABEN  
CARACTÉRISTIQUES TECHNIQUES  
CARACTERÍSTICAS TÉCNICAS  
CARACTERÍSTICAS TÉCNICAS

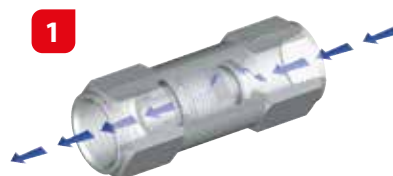

### Norma di Riferimento

Reference standard

Entspricht der Norm

Norme de référence

Normativa de referencia

Norma de referência

1907/2006

REACH ✓

2011/65/CE

RoHS ✓

PED  
2014/68/UE

SILICON  
FREE

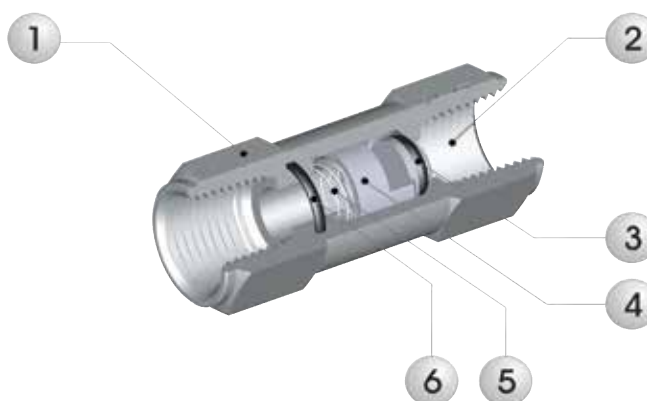

### Materiali e Componenti

- 1 Corpo in ottone nichelato
- 2 Attacco Terminale in ottone nichelato
- 3 Guarnizione O-Ring in NBR
- 4 Otturatore in ottone nichelato o Resina Acetalica
- 5 Molla di mantenimento in acciaio AISI 302
- 6 Guarnizione O-Ring in NBR

IT

### Component Parts and Materials

- 1 Nickel-plated Brass Body
- 2 Nickel-plated Brass Valve Back Part
- 3 NBR O-RING Seals
- 4 Nickel-plated or Acetalic Resin Brass Shutter
- 5 Steel AISI 302 Keep spring
- 6 NBR O-RING Seals

GB

### Komponenten und Materialien

- 1 Körper Messing vernickelt
- 2 Ventilhinterteil Messing vernickelt
- 3 O-Ring NBR
- 4 Verschlusskappe Messing vernickelt oder Lösering Acetal
- 5 Feder Edelstahl AISI 302
- 6 O-Ring NBR

DE

### Matériaux et Composants

- 1 Corps: laiton nickelé
- 2 Embase fileté: laiton nickelé
- 3 Joint torique: NBR
- 4 Clapet: laiton nickelé ou Résine acétal
- 5 Ressort: acier inoxydable AISI 302
- 6 Joint torique: NBR

FR

### Materiales y Componentes

- 1 Cuerpo en latón niquelado
- 2 Parte posterior en latón niquelado
- 3 Junta tórica O-Ring en NBR
- 4 Obturador en latón niquelado o resina acetálica
- 5 Muelle de mantenimiento en acero AISI 302
- 6 Junta tórica O-Ring en NBR

ES

### Materiais e Componentes

- 1 Corpo in Latão Niquelado
- 2 Parte traseira da válvula em Latão niquelado
- 3 Vedação O-Ring em NBR
- 4 Obturador em Latão niquelado ou Resina Acetálica
- 5 Mola de manutenção em aço AISI 302
- 6 Vedação O-Ring em NBR

PT

IT	GB	DE
<p>Questo tipo di valvole permette il libero passaggio in un solo senso (quello indicato dalla freccia) e lo impedisce nel senso contrario.</p> <p>Azionate direttamente dall'aria che le attraversa, vengono normalmente impiegate come dispositivi di sicurezza, consentendo di mantenere in pressione una parte del circuito pur mandando a scarico l'alimentazione.</p>	<p>This kind of valves allow the free passage in only one direction, the one showed with the arrow marked on the body. They do not allow the passage on the opposite way, i.e. non return.</p> <p>They operate directly with the air that goes through, they are normally used as safety device, permitting to keep pressure in a part of the circuit, also when the feeding pressure has been taked off.</p>	<p>Diese Art von Ventilen ermöglicht einen freien Durchgang in einer Richtung (wie durch den Pfeil angedeutet) und blockiert den Durchfluss des Mediums in die Gegenrichtung. Bei Druckabfall unter die durch eine Feder festgelegte Ansprechsgrenze sperrt eine Verschlusskappe den Durchgang ab.</p> <p>Kompakt und platzsparend sind diese Rückschlagventile ein Sicherheitselement, das sich perfekt in den Kreislauf einfügt.</p>

FR	ES	PT
<p>Cette vanne permet le libre passage du fluide dans la direction marquée par la flèche indiquée sur le corps. Elle ne permet pas le passage en sens inverse. Elle est autonome et fonctionne directement avec le fluide qui la traverse.</p> <p>Elle est régulièrement utilisée comme dispositif de sécurité, permettant de maintenir la pression dans une partie du circuit lorsque la pression d'alimentation est coupée.</p>	<p>Este tipo de válvulas permiten el libre paso en un sólo sentido (indicado por la flecha en el cuerpo) y lo impide en el sentido contrario.</p> <p>Accionadas directamente por el aire, vienen normalmente utilizadas como dispositivos de seguridad, consintiendo en mantener en presión una parte del circuito, incluso cuando no existe presión en la alimentación.</p>	<p>Este tipo de válvulas permite a liberação da passagem em apenas um sentido (aquele indicado pela seta) e impedir o fluxo no sentido contrário.</p> <p>Acionadas diretamente pelo ar que as atravessa, são normalmente aplicadas como dispositivos de segurança, permitindo a manutenção da pressão em uma parte do circuito mesmo quando a alimentação da pressão é retirada.</p>

**Pressione Max**

Max Pressures

Max Druckbereich

Pressions Max

Presiones Max

Pressões Max

**8 bar** (0.8 MPa)

**Pressione minima di chiusura garantita**

Guaranteed minimum closing pressure

Garantierter minimaler Schließdruck

Pression de fermeture minimale garantie

Presión mínima garantizada de cierre

Pressão de fechamento mínima garantida

**2 bar** (0.2 MPa)

**Pressione indicativa apertura**

Approximate opening pressure

Öffnungsdruck

Pression d'ouverture

Presión indicativa de apertura

Pressão de abertura aproximada

**0.2 bar** (0.02 MPa)

**Temperature**

Temperatures

Temperatur

Températures

Temperaturas

Temperaturas

**- 20 °C**

**+ 80 °C**

**Con Guarnizioni FKM**

With FKM Seals

Mit FKM Dichtung

Avec joints FKM

Con juntas FKM

Com Vedação em FKM

**6062**

**6063**

- 15 °C

- 15 °C

+ 200 °C

+ 200 °C

**Fluidi compatibili**

Aria compressa

Fluids

Compressed air

Geeignete Medien

Druckluft

Fluides compatibles

Aire comprimé

Fluidos compatibles

Aire comprimido

Fluidos compatíveis

Ar comprimido



Filettatura	IT	Threads	GB	Gewindearten	DE
<p>Gas cilindrica conforme ISO 228. Metrica conforme ISO R/262.</p>		<p>Parallel gas in conformity with ISO 228. Metric in conformity with ISO R/262.</p>		<p>Zylindrisches Gewinde nach Norm ISO 228. Metrisches Gewinde nach Norm ISO R/262.</p>	
Filetages	FR	Roscas	ES	Roscas	PT
<p>Filetage cylindrique conforme ISO 228. Filetage métrique conforme: ISO R/262.</p>		<p>Gas cilíndrica conforme ISO 228. Métrica conforme ISO R/262.</p>		<p>Gas paralela conforme ISO 228. Métrica conforme ISO R/262.</p>	

## 6062

### VALVOLA UNIDIREZIONALE FEMMINA-FEMMINA

FEMALE-FEMALE NON RETURN VALVE  
 RÜCKSCHLAGVENTIL INNEN- / INNENGEWINDE  
 CLAPET ANTI-RETOUR, FEMELLE/FEMELLE  
 VÁLVULA UNIDIRECCIONAL HEMBRA-HEMBRA  
 VÁLVULA UNIDIRECCIONAL FÊMEA-FÊMEA

Code NBR	Code FKM	A	B	L	CH	Pack.
06062 00 001	06062 00 006	M5	5.5	26.5	8	10
06062 00 002	06062 00 007	1/8	8.5	35.5	13	10
06062 00 003	06062 00 008	1/4	11	43	17	10
06062 00 004	06062 00 009	3/8	12	58	24	10
06062 00 005	06062 00 010	1/2	15	63	24	10

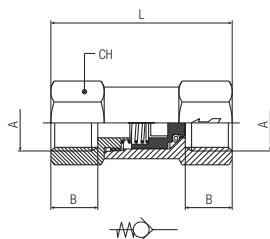

## 6063

### VALVOLA UNIDIREZIONALE MASCHIO-FEMMINA

MALE-FEMALE NON-RETURN VALVE  
 RÜCKSCHLAGVENTIL AUSSEN- / INNENGEWINDE  
 CLAPET ANTI-RETOUR, MÂLE/FEMELLE  
 VÁLVULA UNIDIRECCIONAL MACHO-HEMBRA  
 VÁLVULA ANTI-RETORNO MACHO-FÊMEA

Code NBR	Code FKM	A	B	C	L	CH	Pack.
06063 00 001	06063 00 006	M5	5.5	4	34.5	8	10
06063 00 002	06063 00 007	1/8	8.5	6	37.5	14	10
06063 00 003	06063 00 008	1/4	11	8	46.5	17	10
06063 00 004	06063 00 009	3/8	12	9	61	24	10
06063 00 005	06063 00 010	1/2	15	10	64	24	10

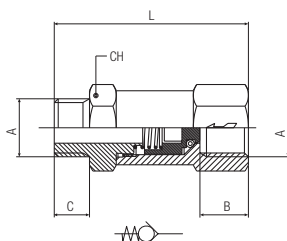

## 6162

### VALVOLA UNIDIREZIONALE MASCHIO - MASCHIO

MALE-MALE UNIDIRECTIONAL VALVE  
 UNIDIREKTIONALES VENTIL AUSSEN - AUSSENGEWINDE  
 VANNE UNIDIRECTIONNELLE MÂLE - MÂLE  
 VÁLVULA UNIDIRECCIONAL MACHO - MACHO  
 VÁLVULA UNIDIRECCIONAL MACHO - MACHO

Code	A	B	L	CH	Pack.
06162 00 001	M5	4	33.5	8	10
06162 00 002	1/8	6	34	14	10
06162 00 003	1/4	8	42	17	10
06162 00 004	3/8	9	55.5	24	10
06162 00 005	1/2	10	57.5	24	10

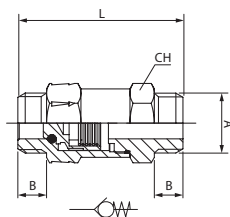

# 6163

## VALVOLA UNIDIREZIONALE MASCHIO- FEMMINA

MALE-FEMALE UNIDIRECTIONAL VALVE  
 UNIDIREKTIONALES VENTIL AUSSEN - INNENGEWINDE  
 VANNE UNIDIRECTIONNELLE MÂLE - FEMELLE  
 VÁLVULA UNIDIRECCIONAL MACHO - HEMBRA  
 VÁLVULA UNIDIRECCIONAL MACHO - FÊMEA

Code	A	B	L	CH	Pack.
06163 00 001	M5	4	24.5	8	10
06163 00 002	1/8	6	32	13	10
06163 00 003	1/4	8	38.5	17	10
06163 00 004	3/8	9	52	24	10
06163 00 005	1/2	10	56.5	24	10

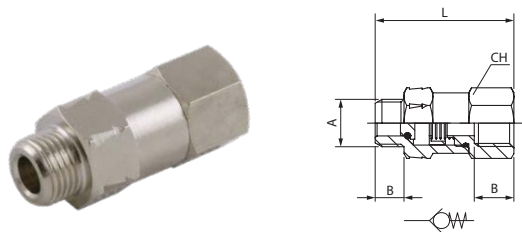

### Caratteristiche di flusso con scarico d'aria libero

- Flow characteristics with exhaust air free
- Durchflusswerte mit offenem Durchgang
- Caractéristiques du débit - passage libre ouvert
- Características de caudal con escape de aire libre
- Características de vazão com saída de ar livre



### Caratteristiche di flusso con perdite di carico di 1 bar

- Flow characteristics and pressure drop of 1 bar
- Durchflusswerte mit einem Druckabfall von 1 bar
- Caractéristiques du débit - perte de charge 1 bar
- Características de caudal con pérdida de carga de 1 bar
- Características de vazão com perda de carga de 1 bar

6062 - 6063 - 6162 - 6163

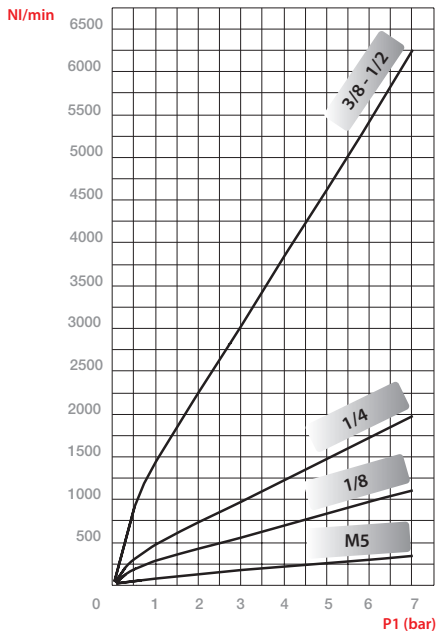

6062 - 6063 - 6162 - 6163

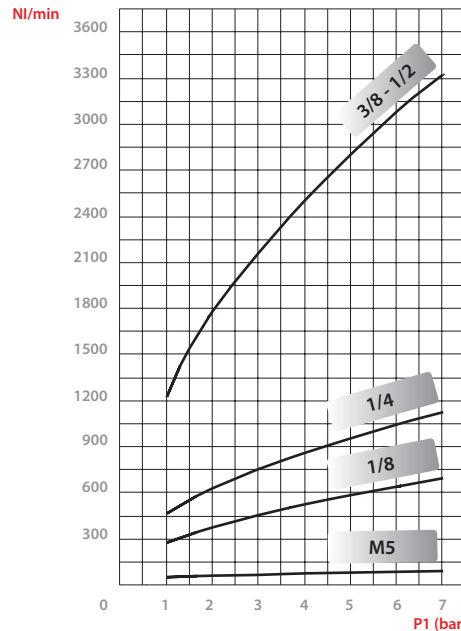

### NI/min

Portata d'aria Q a 0°C e 1013 mbar  
 Air rate Q at 0°C and 1013 mbar  
 Luftdurchlass Q bei 0°C und 1013 mbar  
 Débit d'air Q à 0°C et 1013 mbar  
 Caudal de Aire Q 0°C y 1013 mbar  
 Vazão de ar Q 0°C e 1013 mbar

## 6064

### VALVOLA UNIDIREZIONALE AUTOMATICA

PUSH-IN CONNECTIONS NON-RETURN VALVE

RÜCKSCHLAGVENTIL MIT STECKANSCHLUSS

CLAPET ANTI-RETOUR, CONNEXION INSTANTANEE

VÁLVULA UNIDIRECCIONAL TUBO-TUBO

VÁLVULA ANTI-RETORNO COM CONEXÕES PUSH-IN

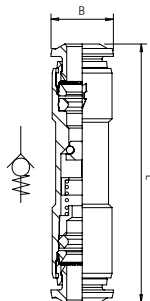

Code	Tube	L	B	Pack.
06064 00 001	4	44.5	10	10
06064 00 002	6	52	12.5	10
06064 00 003	8	56	14	10

Portata (NI/min) - Flow rate (NI/min) - Fluss (NI/min)  
Débit (NI/min) - Caudal (NI/min) - Vazão (NI/min)

Ø	ΔP=0,5	ΔP=1	ΔP= *
4	85	120	205
6	110	330	470
8	260	600	1110

\* Scarico libero - Exhaust Free - Kostenlose Auspuff - Échappement libre - Escape Libre - Descarga livre.

## 57065

### RACCORDO DIRITTO MASCHIO CILINDRICO CON VALVOLA UNIDIREZIONALE

NON-RETURN - PUSH-IN - PARALLEL THREAD

RÜCKSCHLAVENTILE - DURCHFLUSS VOM STECKANSCHLUSS ZU ZYLINDRISCHEM AUSSENGEWINDE

CLAPET ANTI-RETOUR - CONNEXION INSTANTANEE - FILETAGE MALE

VALVOLA UNIDIRECCIONAL - TUBO - ROSCA MACHO

VÁLVULA ANTI-RETORNO - CONEXOES PUSH-IN - ROSCA MACHO

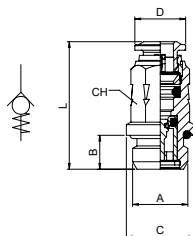

Code	Tube	A	B	C	D	L	CH	Pack.
57065 00 001	4	M5	3.6	7.5	9.8	37	8	10
57065 00 002	4	1/8	5.4	13	9.8	40.5	11	10
57065 00 003	6	1/8	5.4	13	12.5	46	12	10
57065 00 004	6	1/4	8	13	12.5	30	12	10
57065 00 005	8	1/8	5.4	13.8	14	47	12	10
57065 00 006	8	1/4	8	16	14	30.5	14	10
57065 00 007	10	1/4	8	16	17	34.5	17	10
57065 00 008	10	3/8	9	20	17	34.5	17	10
57065 00 009	12	3/8	9	20	19.5	39	20	10
57065 00 010	12	1/2	10	25	19.5	44	20	10

**New**

**VALVOLA UNIDIREZIONALE O DI NON RITORNO - CW510L**

UNIDIRECTIONAL VALVES OR NON RETURN VALVES - CW510L  
 RÜCKSCHLAGVENTILE - CW510L  
 CLAPET ANTI-RETOUR - CW510L  
 VÁLVULAS UNIDIRECCIONALES O ANTIRETORNO - CW510L  
 VÁLVULAS UNIDIRECIONAIS OU ANTI-RETORNO - CW510L



**CARATTERISTICHE TECNICHE**

TECHNICAL CHARACTERISTICS  
 TECHNISCHE ANGABEN  
 CARACTÉRISTIQUES TECHNIQUES  
 CARACTERÍSTICAS TÉCNICAS  
 CARACTERÍSTICAS TÉCNICAS



**Norma di Riferimento**

Reference standard

Entspricht der Norm

Norme de référence

Normativa de referencia

Norma de referência

1907/2006  
**REACH** ✓

2011/65/CE  
**RoHS** ✓

PED  
 2014/68/UE

SILICON  
 FREE

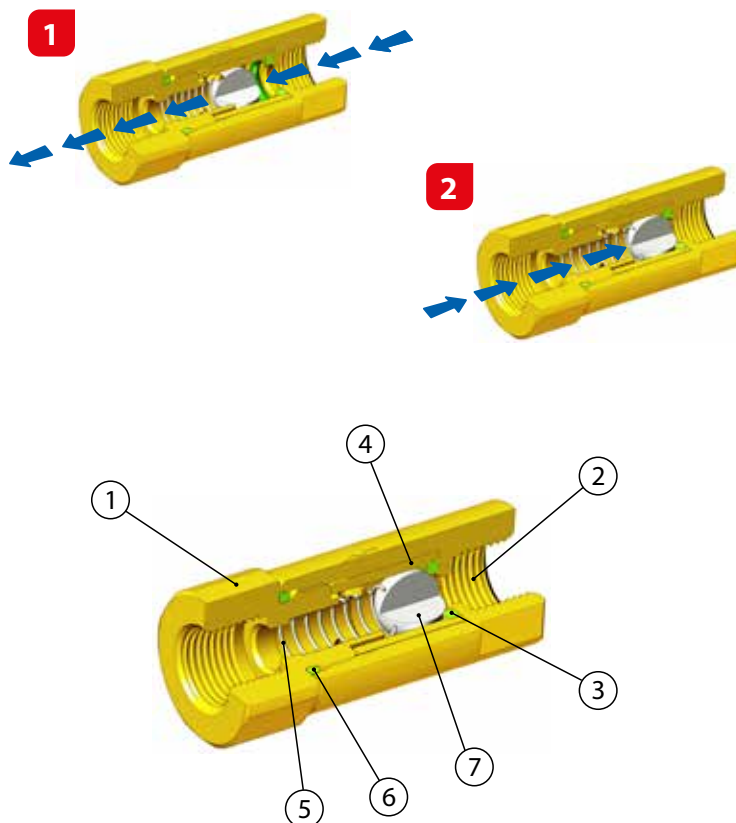

Materiali e Componenti	IT	Component Parts and Materials	GB	Komponenten und Materialien	DE
1 Corpo in Ottone CW510L		1 CW510L brass body		1 Körper Messing CW510L	
2 Attacco Terminale in ottone CW510L		2 CW510L Brass Valve Back Part		2 Ventilhinterteil Messing CW510L	
3 Guarnizione O-ring FKM Alimentare		3 O-Ring seal in FKM Food		3 O-Ringdichtung FKM lebensmittelkonform	
4 Bussola in ottone CW510L		4 CW510L Brass Compass		4 Kompass Messing CW510L	
5 Molla di mantenimento in acciaio AISI 302		5 Steel AISI 302 Keep spring		5 Feder Edelstahl AISI 302	
6 Guarnizione O-ring FKM Alimentare		6 O-Ring seal in FKM Food		6 O-Ringdichtung FKM lebensmittelkonform	
7 Sfera in acciaio AISI 420		7 AISI 420 steel ball		7 Kugel aus Stahl AISI 420	

Matériaux et Composants	FR	Materiales y Componentes	ES	Materiais e Componentes	PT
1 Corps en laiton CW510L		1 Cuerpo en latón CW510L		1 Corpo em latão CW510L	
2 Embase fileté: laiton CW510L		2 Parte posterior en latón CW510L		2 Parte traseira da válvula em Latão CW510L	
3 Joint O-ring FKM qualité alimentaire		3 Junta tórica en FKM alimentario		3 Vedação o-ring em FKM alimentício	
4 Boussole: Laiton CW510L		4 Brújula en latón CW510L		4 Bússola em Latão CW510L	
5 Ressort: acier inoxydable AISI 302		5 Muelle de mantenimiento en acero AISI 302		5 Mola de manutenção em aço AISI 302	
6 Joint O-ring FKM qualité alimentaire		6 Junta tórica en FKM alimentario		6 Vedação o-ring em FKM alimentício	
7 Bille en acier AISI 420		7 Bola de acero AISI 420		7 Esfera de aço AISI 420	



Filettatura	IT	Threads	GB	Gewindearten	DE
Gas cilindrica conforme ISO 228.		Parallel gas in conformity with ISO 228.		Zylindrisches Gewinde nach Norm ISO 228.	

Filetages	FR	Roscas	ES	Roscas	PT
Filetage cylindrique conforme ISO 228.		Gas cilíndrica conforme ISO 228.		Gas paralela conforme ISO 228.	

<b>IT</b>	<b>GB</b>	<b>DE</b>
<p>Questo tipo di valvole permette il libero passaggio in un solo senso (quello indicato dalla freccia) e lo impedisce nel senso contrario.</p> <p>Azionate direttamente dal fluido che le attraversa, vengono normalmente impiegate come dispositivi di sicurezza, consentendo di mantenere in pressione una parte del circuito pur mandando a scarico l'alimentazione.</p>	<p>This kind of valves allow the free passage in only one direction, the one showed with the arrow marked on the body. They do not allow the passage on the opposite way, i.e. non return.</p> <p>They operate directly with the fluid that goes through, they are normally used as safety device, permitting to keep pressure in a part of the circuit, also when the feeding pressure has been taken off.</p>	<p>Diese Art von Ventilen erlaubt den freien Durchgang nur in eine Richtung, die mit dem Pfeil auf dem Gehäuse gekennzeichnet ist. Sie lassen den Durchgang in die entgegengesetzte Richtung nicht zu, d.h. ohne Rücklauf.</p> <p>Sie arbeiten direkt mit der durchfließenden Flüssigkeit, Sie werden normalerweise als Sicherheitsvorrichtung verwendet, die es ermöglichen, den Druck in einem Teil des Kreislaufs aufrechtzuerhalten, auch wenn der Speisendruck abgenommen wurde.</p>

<b>FR</b>	<b>ES</b>	<b>PT</b>
<p>Cette vanne permet le libre passage du fluide dans la direction marquée par la flèche indiquée sur le corps. Elle ne permet pas le passage en sens inverse.</p> <p>Elle est autonome et fonctionne directement avec le fluide qui la traverse. Elle est régulièrement utilisée comme dispositif de sécurité, permettant de maintenir la pression dans une partie du circuit lorsque la pression d'alimentation est coupée.</p>	<p>Este tipo de válvulas permiten el libre paso en un sólo sentido (indicado por la flecha en el cuerpo) y lo impide en el sentido contrario.</p> <p>Accionadas directamente por el fluido, vienen normalmente utilizadas como dispositivos de seguridad, consintiendo en mantener en presión una parte del circuito, incluso cuando no existe presión en la alimentación.</p>	<p>Este tipo de válvulas permite a liberação da passagem em apenas um sentido (aquele indicado pela seta) e impedir o fluxo no sentido contrário.</p> <p>Acionadas diretamente pelo ar que as atravessa, são normalmente aplicadas como dispositivos de segurança, permitindo a manutenção da pressão em uma parte do circuito mesmo quando a alimentação da pressão é retirada.</p>

**Bar**

**Pressione Max**

Max Pressures

Max Druckbereich

Pressions Max

Presiones Max

Pressões Max

---

**8 bar** (0.8 MPa)

**Bar**

**Pressione minima di chiusura garantita**

Guaranteed minimum closing pressure

Garantierter minimaler Schließdruck

Pression de fermeture minimale garantie

Presión mínima garantizada de cierre

Pressão de fechamento mínima garantida

---

**2 bar** (0.2 MPa)

**Bar**

**Pressione indicativa apertura**

Approximate opening pressure

Öffnungsdruck

Pression d'ouverture

Presión indicativa de apertura

Pressão de abertura aproximada

---

**0.2 bar** (0.02 MPa)

**Temperature**

Temperatures

Temperatur

Températures

Temperaturas

Temperaturas

---

**- 15 °C**

**+ 190 °C**

**Portata a scarico libero 6 bar**

Exhaust Free flow rate 6 bar

Fluss Kostenlose Auspuff 6 bar

Débit échappement libre 6 bar

Caudal escape Libre 6 bar

Vazão descarga livre 6 bar

<b>Ø 1/8</b>	600 NI/min
<b>Ø 1/4</b>	625 NI/min

**Fluidi compatibili**

Aria compressa / Vuoto / Acqua / Alimenti

Fluids

Compressed air / Vacuum / Water / Food

Geeignete Medien

Druckluft / Vakuum / Wasser / Lebensmittel

Fluides compatibles

Air comprimé / Vide / Eau / Boissons

Fluidos compatibles

Aire comprimido / Vacío / Agua / Alimentos

Fluidos compatíveis

Ar comprimido / Vácuo / Água / Alimentos

**6061**

**VALVOLA UNIDIREZIONALE FEMMINA-FEMMINA**  
 FEMALE-FEMALE NON RETURN VALVE  
 RÜCKSCHLAGVENTIL INNEN- / INNENGEWINDE  
 CLAPET ANTI-RETOUR, FEMELLE/FEMELLE  
 VÁVULA UNIDIRECCIONAL HEMBRA-HEMBRA  
 VALVULA UNIDIRECCIONAL FÊMEA-FÊMEA



Code	A	B	L	CH1	CH2	Pack.
<b>06061 000 07 CW</b>	<b>1/8</b>	8.5	41.5	17	14	25
<b>06061 000 08 CW</b>	<b>1/4</b>	11	48	20	17	25

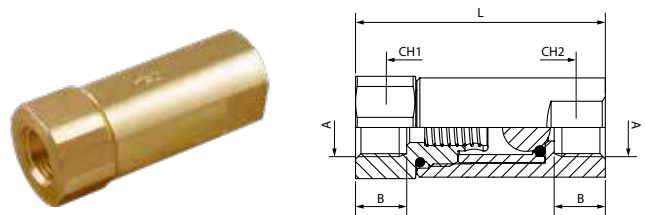

**RACCORDI OTTURATI**

STOP FITTING  
 SPERRVENTILVERSCHRAUBUNG  
 RACCORDS AVEC CLAPET  
 RACOR AUTOMATICO OBTURADO  
 CONEXAO PUSH-IN COM RETENÇÃO



**CARATTERISTICHE TECNICHE**  
 TECHNICAL CHARACTERISTICS  
 TECHNISCHE ANGABEN  
 CARACTÉRISTIQUES TECHNIQUES  
 CARACTERÍSTICAS TÉCNICAS  
 CARACTERÍSTICAS TÉCNICAS



**Norma di Riferimento**

- Reference standard
- Entspricht der Norm
- Norme de référence
- Normativa de referencia
- Norma de referência

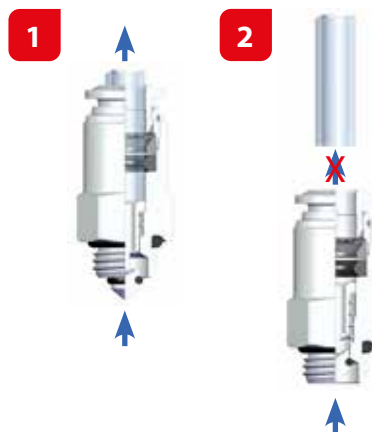

IT	Component Parts and Materials	GB	Komponenten und Materialien	DE
1	Corpo in Ottone nichelato	1	Körper Messing vernickelt	
2	Spintore sgancio tubo in Ottone nichelato	2	Rohr Lösering Messing vernickelt	
3	Capsula in Ottone nichelato	3	Haltering Messing vernickelt	
4	Pinza d'aggraffaggio in Acciaio INOX AISI 301	4	Zahnscheibe Edelstahl AISI 301	
5	Anello di sicurezza in tecnopolimero	5	Sicherheitsring im Technopolymer	
6	Guarnizione sagomata in NBR	6	Dichtung NBR	
7	Molla in Acciaio INOX AISI 302	7	Feder Edelstahl AISI 302	
8	Guarnizioni in NBR	8	Lippendichtung NBR	
9	Otturatore in Ottone Nichelato	9	Verschluss Messing vernickelt	

FR	Materials y Componentes	ES	Materiais e Componentes	PT
1	Corps: laiton nikelé	1	Cuerpo em latão niquelado	1
2	Poussoir: Laiton nikelé	2	Anillo de extracción tubo en latón niquelado	2
3	Capsule de retenue: Laiton nikelé	3	Cápsula en latón niquelado	3
4	Rondelle d'accrochage: AISI 301	4	Pinza de agarre en acero inox AISI 301	4
5	Anneau de sécurité à technopolymère	5	Anillo de seguridad en tecnopolímero	5
6	Joint: NBR	6	Junta de forma en NBR	6
7	Ressort: acier inoxydable AISI 302	7	Muelle de mantenimiento en acero AISI 302	7
8	Joint en NBR	8	Junta en NBR	8
9	Lapet: Laiton nikelé	9	Obturador en latón niquelado	9

IT	GB	DE
L'inserimento del tubo nel raccordo determina lo spostamento dell'otturatore permettendo così il libero passaggio di aria. Lo sgancio del tubo invece determina la chiusura dell'otturatore con il conseguente arresto del flusso di aria proveniente dal raccordo.	The connection with tube moves the shutter in order to let the air flow. Disconnection moves shutter back and shuts the air flow.	Schlauchanschluss ermöglicht einen freien Durchgang in einer Richtung. Eine Schlauchtrennung blockiert den Durchgang.

FR	ES	PT
L'insertion du tube dans le raccord détermine le déplacement du clapet permettant le libre passage de l'air. La disconnection du tube, en revanche, provoque la fermeture du clapet avec pour conséquence l'arrêt du flux provenant du raccord.	La inserción de la manguera en el conector determina el desplazamiento del obturador, permitiendo de esta manera el libre pasaje del aire. El desenganche de la manguera determina, en cambio, el cierre del obturador con el consiguiente bloque del flujo de aire que procede del conector.	A conexao de tubo permite a liberacao da passagem em apenas um sentido. A desconexao impide o fluxo no sentido contrario.



### Pressioni

Pressures

Druckbereich

Pressions

Presiones

Pressões

**10 bar** (1 MPa)



### Temperature

Temperatures

Temperatur

Températures

Temperaturas

Temperaturas

- 20 °C

+ 80 °C



### Fluidi compatibili

Aria compressa

Fluids

Compressed air

Geeignete Medien

Druckluft

Fluides compatibles

Air comprimé

Fluidos compatibles

Aire comprimido

Fluidos compatíveis

Ar comprimido



### Tubi di Collegamento

Tubi in materiale plastico:

PA6, PA11, PA12, Polietilene, \*Poliuretano, PTFE, FEP.

\*Utilizzo da 90 a 98 Shore, per la massima prestazione è consigliato 98 Shore A.

IT

### Connection Tubes

Plastic tubes:

PA6, PA11, PA12, Polyethylene, \*Polyurethane, PTFE, FEP.

\*Use from 90 to 98 Shore, for maximum performance is recommended 98 Shore A.

GB

### Geeignete Rohre

Kunststoffrohre:

PA6, PA11, PA 12, Polyethylene, \*Polyurethan, PTFE, FEP.

\*Verwenden Sie 90 bis 98 Shore, für maximale Leistung wird 98 Shore A empfohlen.

DE

### Tubes Conseillés

Tubes plastiques:

PA6, PA11, PA12, Polyéthylène, \*Polyuréthane, PTFE, FEP.

\*Utilisation de 90 à 98 Shore, pour une performance maximale recommandée 98 Shore A.

FR

### Tubos de Conexión

Tubos en material plástico:

PA6, PA11, PA 12, Polietileno, \*Poliuretano, PTFE, FEP.

\*Uso de 90 a 98 Shore, para un máximo rendimiento se recomienda 98 Shore A.

ES

### Tubos de Conexão

Tubos em material plástico:

PA6, PA11, PA12, Polietileno, \*Poliuretano, PTFE, FEP.

\*Uso de 90 a 98 Shore, para o desempenho máximo é recomendado 98 Shore A.

PT



### Filettatura

Gas cilindrica conforme ISO 228.

IT

### Threads

Parallel gas in conformity with ISO 228.

GB

### Gewindearten

Zylindrisches Gewinde nach Norm ISO 228.

DE

### Filetages

Filetage cylindrique conforme ISO 228.

FR

### Roscas

Gas cilíndrica conforme ISO 228.

ES

### Roscas

Gas paralela conforme ISO 228.

PT

## 57064

### RACCORDO DIRITTO MASCHIO CILINDRICO OTTURATO

STOP FITTING - PARALLEL THREAD

SPERRVENTILVERSCHRÄUBUNG - ZYLINDRISCHEM AUSSENGEWINDE

RACCORDS AVEC CLAPET - FILETAGE MALE

RACOR AUTOMÁTICO OBTURADO - ROSCA MACHO

CONEXAO PUSH-IN COM RETENÇÃO - ROSCA MACHO

Code	Tube	A	B	D	L	CH	F	G	Pack.
57064 00 001	6	1/8	5.4	12.5	29	13	2.3	4.2	10
57064 00 002	6	1/4	7.1	12.5	30.5	16	2	4.2	10
57064 00 003	8	1/8	5.4	14.3	28	15	3.2	4.2	10
57064 00 004	8	1/4	7.1	14.3	29	16	3.1	6.2	10

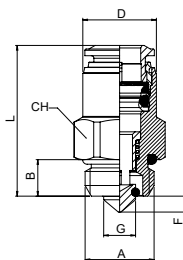

**VALVOLE DI BLOCCO**

BLOCK VALVE  
STOPVENTIL  
STOP-VÉRIN  
VÁLVULAS DE BLOQUEO  
VÁLVULAS DE BLOQUEIO



**CARATTERISTICHE TECNICHE**

TECHNICAL CHARACTERISTICS  
TECHNISCHE ANGABEN  
CARACTÉRISTIQUES TECHNIQUES  
CARACTERÍSTICAS TÉCNICAS  
CARACTERÍSTICAS TÉCNICAS



**Norma di Riferimento**

Reference standard

Entspricht der Norm

Norme de référence

Normativa de referencia

Norma de referência

1907/2006  
**REACH** ✓

2011/65/CE  
**RoHS** ✓

PED  
2014/68/UE

**SILICON  
FREE**

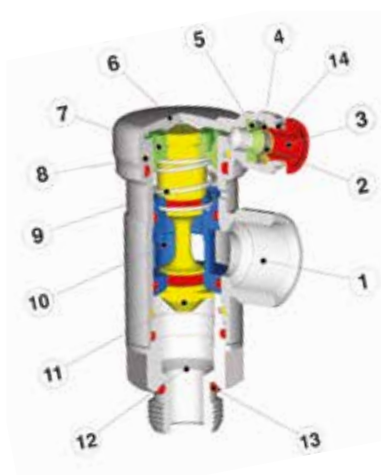

**Portata nominale (6 bar)**

Flow rate (6 bar)

Nenndurchfluss (6 bar)

Débit (6 bar)

Caudal nominal (6 bar)

Vazão nominal (6 bar)

1/8	1/4
750 NI/min	1420 NI/min
3/8	1/2
2100 NI/min	2500 NI/min



**Fluidi**

Aria filtrata lubrificata o non lubrificata

**Fluids**

Filtered and lubricated compressed air as well as non lubricated air

**Medien**

Druckluft gefiltert, geölt oder ungeölt.

**Fluides**

Aire comprimé, filtré, lubrifié ou non lubrifié.

**Fluidos**

Aire filtrado lubricado o no lubricado

**Fluidos**

Ar filtrado e lubricado ou não lubricado

Materiali e Componenti	IT	Component Parts and Materials	GB	Komponenten und Materialien	DE
1 Corpo in Ottone Nichelato		1 Nickel plated brass Body		1 Körper Messing vernickelt	
2 Anello di sicurezza in tecnopolimero		2 Technopolymeric Safety ring		2 Sicherungsring Technopolymer	
3 Spintore sgancio tubo in Resina Acetalica		3 Acetalic Resin Collect		3 Rohr Lösering Acetal	
4 Pinza d'aggraffaggio in acciaio INOX AISI 301		4 Steel Clamping Washer INOX AISI 301		4 Zahnscheibe Edelstahl AISI 301	
5 Guarnizione a labbro in NBR		5 NBR Lip seal		5 Lippendichtung NBR	
6 Coperchio orientabile in Ottone Nichelato		6 Nickel plated brass Orienting Cover Cap		6 Abdeckung drehbar Messing vernickelt	
7 Guarnizione a labbro in Poliuretano		7 Polyuretane Lip seal		7 Lippendichtung Polyurethan	
8 Seeger in Bronzo		8 Bronze Seeger		8 Seegerring Bronze	
9 Molla in acciaio INOX AISI 302		9 Steel Spring		9 Feder Edelstahl AISI 302	
10 Supporto otturatore in Ottone		10 Brass Shutter Support		10 Verschlussunterstützung Messing	
11 Otturatore in Ottone		11 Brass Shutter		11 Verschluss Messing	
12 Basetta orientabile in Ottone Nichelato		12 Nickel plated brass Orienting Base		12 Einschraubkörper drehbar Messing vernickelt	
13 Guarnizioni in NBR		13 NBR O-RING		13 Dichtung NBR	
14 Capsula in ottone nichelato		14 Nickel plated brass Capsule		14 Haltering Messing vernickelt	

Matériaux et Composants	FR	Materiales y Componentes	ES	Materiais e Componentes	PT
1 Corps: laiton nickelé		1 Cuerpo en latón niquelado		1 Corpo em Latão Niquelado	
2 Anneau de sécurité: Technopolymère		2 Anillo de seguridad en tecnopolimero		2 Anel de segurança em tecnopolimero	
3 Poussoir: Résine acétal		3 Anillo extracción tubo en resina acetálica		3 Anilha em Resina Acetálica	
4 Rondelle d'accrochage: AISI 301		4 Pinza de agarre en acero INOX AISI 301		4 Pinça de travamento em aço INOX AISI 301	
5 Joint à lèvres: NBR		5 Junta de labio en NBR		5 Vedação em NBR	
6 Couvercle: laiton nickelé		6 Cuerpo orientable en latón niquelado		6 Cobertura orientável em Latão Niquelado	
7 Joint à lèvres: polyuréthane		7 Junta de labio en poliuretano		7 Vedação em Poliuretano	
8 Clips: bronze		8 Seeger en bronze		8 Anel de Retenção tipo Seeger em Bronze	
9 Ressort: acier inoxydable		9 Muelle en acero INOX AISI 302		9 Mola em aço INOX AISI 302	
10 Support du clapet: laiton		10 Soporte obturador en latón		10 Suporte obturador em Latão	
11 Clapet: laiton		11 Obturador en latón		11 Obturador em Latão	
12 Embase orientable: laiton nickelé		12 Base orientable en latón niquelado		12 Base orientável em Latão Niquelado	
13 Joint torique: NBR		13 Junta en NBR		13 Vedação O-Ring em NBR	
14 Capsule de retenue: Laiton nickelé		14 Cápsula en latón niquelado		14 Cápsula em Latão Niquelado	



### Pressione d'esercizio

Working pressure

Betriebsdruck

Pression de service

Presión de ejercicio

Pressão de trabalho

**0.3 bar** (0.03 MPa)

**10 bar** (1 MPa)



### Temperatura d'esercizio

Working temperature

Betriebstemperatur

Température de service

Temperatura de ejercicio

Temperatura de trabalho

**- 20 °C**

**+ 80 °C**

**CODE: 8880**

**U**

#### UNIDIREZIONALE

UNI-DIRECTIONAL

RÜCKSCHLAG

UNI-DIRECTIONNEL

UNIDIRECCIONAL

UNIDIRECCIONAL

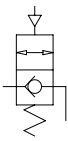

**CODE: 8890**

**B**

#### BI-DIREZIONALE

BI-DIRECTIONAL

BI-DIREKTIONAL

BI-DIRECTIONNEL

BIDIRECCIONAL

BIDIRECCIONAL

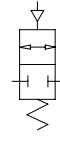

**IT**

Le valvole di blocco Aignep sono dispositivi a pilotaggio pneumatico per il controllo del movimento di un cilindro. Montate direttamente sugli attacchi di ingresso ed uscita del cilindro consentono di bloccare la corsa del pistone in caso di caduta di pressione del pilotaggio.

Sono utilizzate come sistema di sicurezza: in caso di arresto di emergenza, rottura di un tubo o mancanza d'aria bloccano i dispositivi movimentati dai cilindri evitando danneggiamenti delle parti o rischi di lesioni per gli operatori.

E' possibile utilizzarle anche per arrestare lo stelo in posizioni intermedie quando le applicazioni richiedono questa soluzione.

Versioni: sono disponibili nella versione unidirezionale e bidirezionale.

Portata: le valvole sono a passaggio totale poiché non vi sono riduzioni di sezione ed il flusso non attraversa la molla.

Compattezza e versatilità: gli ingombri sono molto ridotti ed è possibile orientare sia la connessione filettata che il supporto dell'attacco del tubo per il pilotaggio.

Attacco filettato: è possibile connettere un regolatore di flusso all'ingresso della valvola per la regolazione della velocità del cilindro.

**GB**

The AIGNEP's block valves are pneumatic driving devices used to control the movement of the cylinder. Assembled directly on the inlet and outlet ports of the cylinder allow to lock the piston stroke in case of pressure drop of the driving.

They are used as safety devices in case of emergency stop, brake of a tube or air missing, they lock the apparatus moved by the cylinder avoiding damages to the devices or injury risks for the runners.

It is also possible to use them to stop the piston into intermediate positions whenever the application requires such solutions.

Versions: They are available in uni-direction and bi-directional versions

Flow rate: These valves are full bore, there do not have reduction of section and the flow does not pass through the spring.

Compactness and Versatility: The overall dimensions are extremely reduced and it is possible to orient both the threaded connection as well as the hose connection for the driving.

Threaded connection: It is possible to connect the flow regulator at the inlet of the valve in order to adjust the speed of the cylinder.

**DE**

Die Aignep Stoppverschraubungen sind pneumatisch gesteuerte Ventile, mit denen die Bewegung des Zylinders gesteuert werden kann.

Direkt montiert an den Anschlüssen (Ein- und Ausgang) des Zylinders ermöglichen sie bei Druckabfall des Steueranschlusses die Zylinderbewegung zu stoppen und blockieren.

Sie werden als ein Sicherheitssystem eingesetzt: im Falle eines Not-Stopp, eines Schlauchbruches oder eines Druckluftabfalles wird die Bewegung des Zylinders gestoppt, um Beschädigungen an Teilen oder Verletzungen an den Arbeitern zu vermeiden.

Sie können auch dazu verwendet werden, um die Zylinderkolbenstange zu positionieren, wenn die Anwendung eine solche Lösung erfordert.

Versionen: Es gibt sie in unidirektionaler- und bidirektionaler Ausführung.

Durchfluss: Diese Ventile sind mit vollem Durchgang, da der Querschnitt sich nicht verringert und der Strömungsweg nicht durch die Feder fließt.

Kompaktheit und Vielseitigkeit: Die Abmessungen sind relativ klein und der Gewindeanschluss sowie auch der Signalanschluss sind schwenkbar.

Gewindeanschluss: Es ist möglich, ein Durchflussregler am Eingang des Ventils zu montieren, um die Geschwindigkeit des Zylinders einzustellen.

**FR**

Les raccords stop-vérin d'AIGNEP sont des dispositifs pneumatiques utilisés pour contrôler le mouvement des vérins. Montés directement sur le vérin, ils permettent de verrouiller la course du piston en cas de chute de pression. Ils sont utilisés comme un système d'arrêt d'urgence lors d'une rupture de tuyau ou d'une baisse de pression de pilotage en bloquant le mouvement du vérin afin d'éviter d'endommager les pièces ou de blesser des personnes.

Il est également possible de les utiliser pour arrêter le piston dans des positions intermédiaires lorsque l'application le demande.

Disponibles en version uni ou bi-directionnel

Débit: Ces raccords sont à passage intégral, ils ne disposent pas de réduction de la section et le flux ne passe pas à travers le ressort.

Compacité et polyvalence: Les dimensions sont relativement compactes et le raccord fileté ainsi que le raccordement du signal de pilotage sont orientables.

Connexion filetée: Il est possible d'assembler un régulateur de débit afin de réguler la vitesse du piston.

**ES**

Las válvulas de bloqueo Aignep son dispositivos a pilotaje neumático para el control del movimiento de un cilindro. Montadas directamente en la entrada y salida del cilindro permiten bloquear la carrera del cilindro en caso de caída de presión en el pilotaje.

Son utilizadas como sistemas de seguridad: en caso de paro de emergencia, rotura de un tubo o falta de aire bloquean los dispositivos en movimiento por el cilindro evitando daños de los mismos o riesgos de los operarios.

Es posible su utilización para parar un cilindro en cualquier posición intermedia si se precisa.

Versiones: Disponibles en versión unidireccional y bidireccional.

Caudal: Las válvulas tienen un paso total, debido a que no existen reducciones de sección y el flujo no pasa por el muelle. Compactas y versátiles: El tamaño es muy reducido y es posible orientar la conexión roscada y el pilotaje.

Rosca: Es posible conectar un regulador de caudal a la válvula de bloqueo para controlar la velocidad del cilindro.

**PT**

As válvulas de bloqueio Aignep são dispositivos pilotados pneumaticamente usados no controle do movimento de um cilindro.

Montadas diretamente nas conexões de entrada e de saída do cilindro permitem travar o curso deste em caso de queda de pressão na pilotagem da válvula.

São utilizadas geralmente como sistemas de segurança: no caso de parada de emergência, ruptura de um tubo ou falta de ar, elas travam os dispositivos movimentados pelos cilindros evitando danificar o equipamentos ou lesionar o operadores.

É possível utilizá-las também executar paradas intermediárias do cilindro quando as aplicações solicitam este tipo de solução.

Versões: são disponíveis na versão unidireccional e bi-direccional. Vazão: as válvulas são de passagem plena. Não existem reduções de secção e o fluxo de ar não atravessa a mola.

Tamanho e versatilidade: O dimensional geral da válvula são muito reduzidos e é possível orientar as direções das conexões roscadas bem como da conexão de pilotagem.

Conexão roscada: é possível conectar uma reguladora de vazão na entrada da válvula para a regulação da velocidade do cilindro.

**8880**

**VALVOLA DI BLOCCO UNIDIREZIONALE**

UNIDIRECTIONAL BLOCK VALVE  
 STOPPVENTIL MIT RÜCKSCHLAG  
 RACCORD STOP-VÉRIN, UNI-DIRECTIONNEL  
 VÁLVULA DE BLOQUEO UNIDIRECCIONAL  
 VÁLVULA DE BLOQUEIO UNIDIRECCIONAL

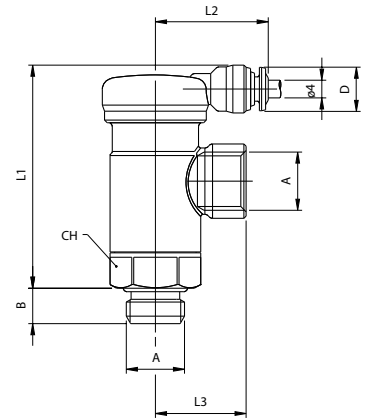
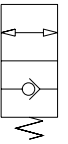

Code	A	B	L1	L2	L3	CH	D	Pack.
08880 00 002	1/8	6	50	25	18.5	18	11	5
08880 00 003	1/4	8	50.5	25	20.5	18	11	5
08880 00 004	3/8	9	62.5	25.5	25	27	11	5
08880 00 005	1/2	10	62.5	25.5	29.5	27	11	5



**Installazione**

- Installation
- Installation
- Installation
- Instalación
- Instalação

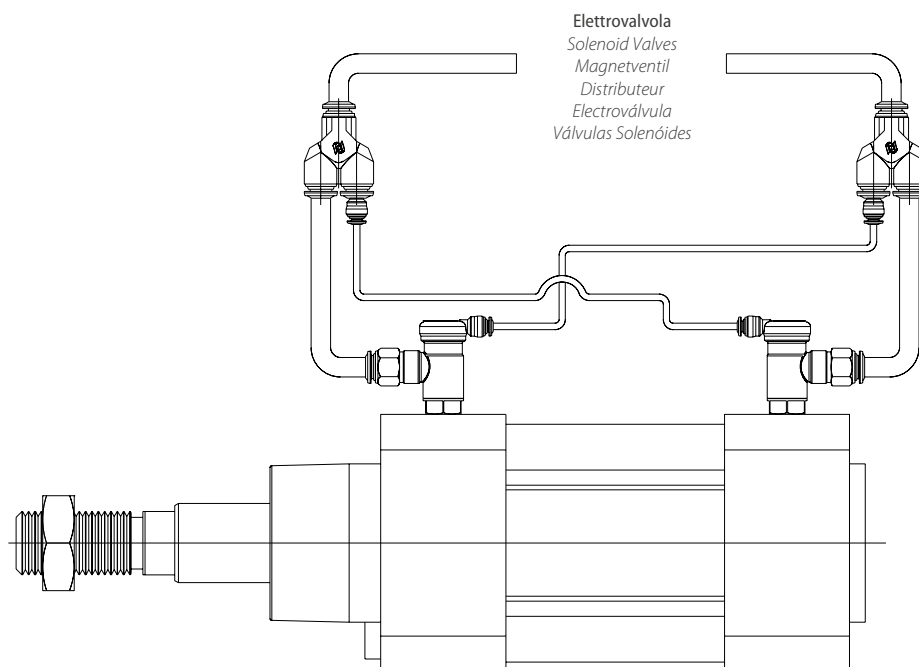

Circuito Pneumatico - Pneumatic Circuit - Pneumatische Schaltung - Circuit pneumatique - Circuito Neumático - Circuito Pneumático

**Pilota**  
 Pilot  
 Steuerung  
 Pilote  
 Pilotaje  
 Piloto

**Alimentazione**  
 Feeding  
 Versorgung  
 Alimentation  
 Alimentación  
 Alimentação

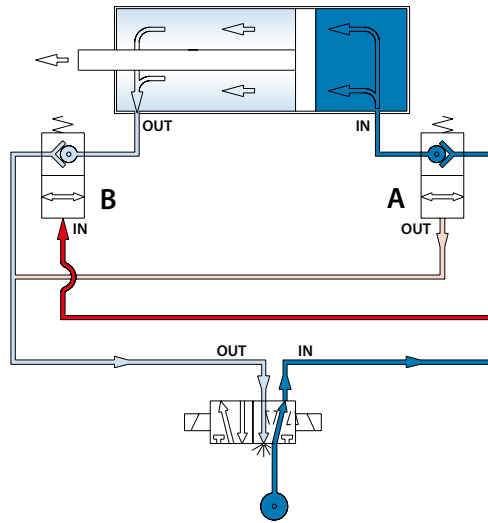

**Cilindro in Movimento**

**IT**

**Cylinder in Action**

**GB**

**Zylinder in Bewegung**

**DE**

Alimentando la valvola di blocco A ed il pilota B si consente il moto del pistone in una direzione.

Feeding the block valve A and the pilot B you allow the movement of the piston in one direction.

Durch die Versorgung des Stoppventiles A und die Steuerung B kann der Kolben in eine Richtung bewegt werden.

Alimentando la valvola di blocco B ed il pilota A si consente il moto del pistone nella direzione opposta.

Feeding the block valve B and the pilot A you allow the movement of the piston in the opposite direction.

Durch die Versorgung des Stoppventiles B und die Steuerung A kann der Kolben in die entgegengesetzte Richtung bewegt werden.

**Vérin en mouvement**

**FR**

**Cilindro en Movimiento**

**ES**

**Cilindro em Movimento**

**PT**

En alimentant la vanne A et le pilote B, on autorise le déplacement du piston dans une direction.

Alimentando la válvula de bloqueo A y el pilotaje B se consiente el movimiento del pistón en una dirección.

Alimentando-se a válvula de bloqueio A e o piloto B se permite o movimento do pistão em uma direção

Afin de déplacer le piston en sens inverse, il faut alimenter la vanne B et le pilote A.

Alimentando la válvula de bloqueo B y el pilotaje A se consiente el movimiento en la dirección opuesta.

Alimentando-se a válvula de bloqueio B e o piloto A se permite o movimento do pistão na direção oposta.

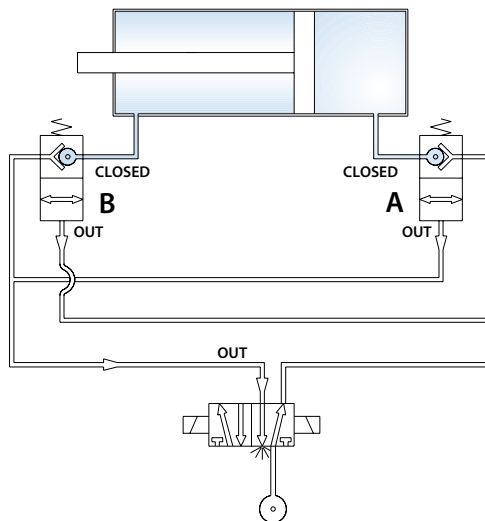

**Cilindro Bloccato**

**IT**

**Stopped Cylinder**

**GB**

**Zylinder Blockiert**

**DE**

Togliendo l'alimentazione all'intero circuito (per es. in caso di emergenza) le valvole di blocco arrestano il cilindro nella posizione in cui si trova, anche in caso che allo stelo siano applicati dei carichi.

Taking away the feeding within the circuit (for example in case of emergency) the block valves lock the cylinder into the position where it is at that moment, even if at the piston are attached some loads.

Trennen Sie die Versorgung der gesamten Steuerung (z.B. bei einem Notfall), so wird durch die Stoppventile an den Zylindern eine Last (Gewicht), die auf den Kolben drückt, blockiert und in der Position gehalten.

**Vérin bloqué**

**FR**

**Cilindro Bloqueado**

**ES**

**Cilindro Parado - Bloqueado**

**PT**

En coupant l'alimentation du circuit (par ex. en cas d'urgence), le bloc vérin bloque la tige dans la position où elle se trouve, même si des charges sont appliquées à la tige.

Cortando la alimentación a la totalidad del circuito (por ej. en caso de emergencia) las válvulas bloquean el cilindro en la posición en la que se encuentra, incluso en el caso en que el cilindro este sometido a alguna carga.

Cortando a alimentação do circuito (ex.: em caso de emergência) as válvulas de bloqueio travam o cilindro na posição em que ele se encontra, mesmo que existam cargas externas conectadas ao cilindro.

**8890**

**VALVOLA DI BLOCCO BIDIREZIONALE**

BIDIRECTIONAL BLOCK VALVE  
 STOPPVENTIL OHNE RÜCKSCHLAG  
 STOP-VÉRIN, BI-DIRECTIONNEL  
 VÁLVULA DE BLOQUEO BIDIRECCIONAL  
 VÁLVULA DE BLOQUEIO BI-DIRECCIONAL

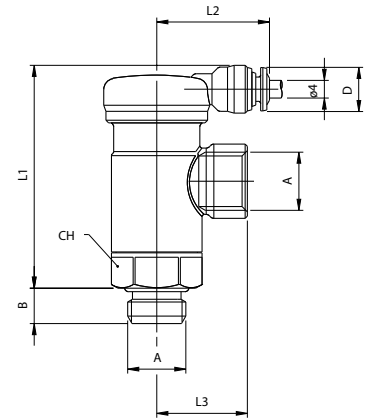

Code	A	B	L1	L2	L3	CH	D	Pack.
08890 00 002	1/8	6	50	25	18.5	18	11	5
08890 00 003	1/4	8	50.5	25	20.5	18	11	5
08890 00 004	3/8	9	62.5	25.5	25	27	11	5
08890 00 005	1/2	10	62.5	25.5	29.5	27	11	5



**Installazione**

Installation

Installation

Installation

Instalación

Instalação

Elettrovalvola  
 Solenoid Valves  
 Magnetventil  
 Distributeur  
 Electroválvula  
 Válvulas Solenóides

Pilotaggio  
 Pilot  
 Steuerung  
 Pilotage  
 Pilotaje  
 Pilotagem

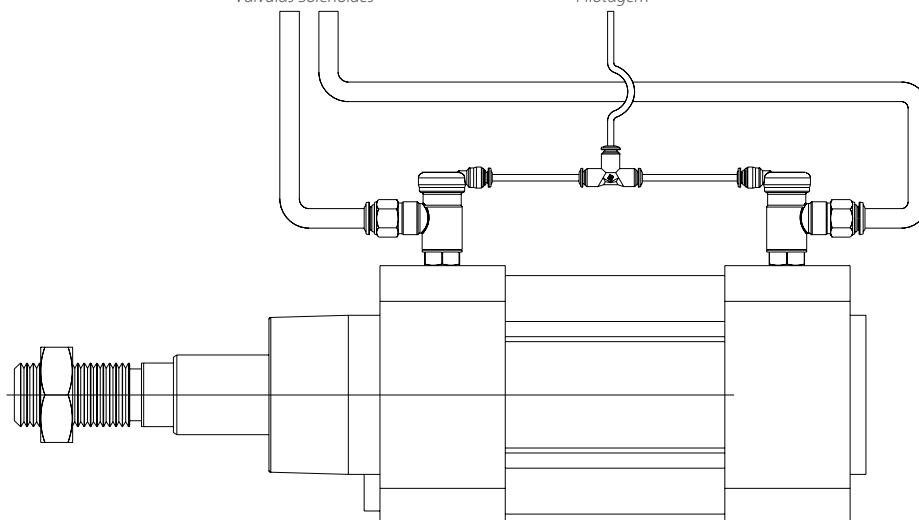

Circuito Pneumatico - Pneumatic Circuit - Pneumatische Schaltung - Circuit pneumatique - Circuito Neumático - Circuito Pneumático

- Pilota**  
Pilot  
Steuerung  
Pilote  
Pilotaje  
Piloto
  
- Alimentazione**  
Feeding  
Versorgung  
Alimentation  
Alimentación  
Alimentação

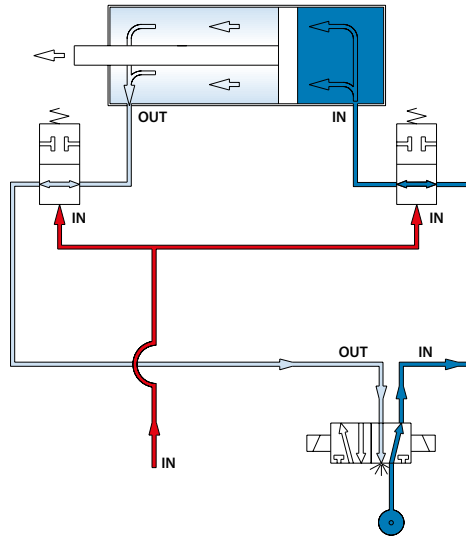

**Cilindro in Movimento**

IT

Il circuito di pilotaggio ed il circuito di alimentazione del cilindro sono indipendenti.

Alimentando il circuito di pilotaggio le valvole di blocco permettono il movimento alternato del cilindro.

**Cylinder in Action**

GB

The driving circuit and the feeding circuit of the cylinder are independent.

Feeding the driving circuit the block valves allow the alternate movement of the cylinder.

**Zylinder in Bewegung**

DE

Die Steuerschaltung und die Versorgungsschaltung des Zylinders (Stoppventile) sind unabhängig voneinander.

Durch die Versorgung der Steuerschaltung der Stoppventile wird die Hubbewegung des Zylinders ermöglicht.

**Vérin en Mouvement**

FR

Le circuit de pilotage et le circuit d'alimentation du vérin (raccords stop-vérin) sont indépendants.

Grâce à l'alimentation séparée du circuit de pilotage des stop-vérin, il est possible d'alterner le mouvement de la tige.

**Cilindro en Movimiento**

ES

El circuito de pilotaje y el circuito de alimentación del cilindro son independientes.

Alimentando el circuito de pilotaje las válvulas de bloqueo permiten el movimiento alternado del cilindro.

**Cilindro em Movimento**

PT

O circuito de pilotagem e o circuito de alimentação do cilindro são independentes.

Alimentando-se o circuito de pilotagem as válvulas de bloqueio permitem o movimento alternado do cilindro.

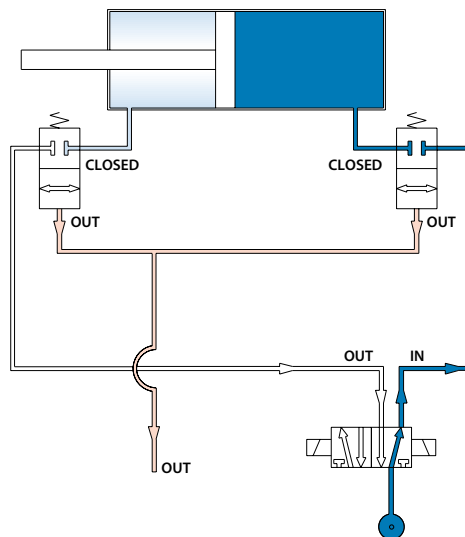

**Cilindro Bloccato**

IT

Togliendo l'alimentazione al circuito di pilotaggio le valvole di blocco arrestano il cilindro nella posizione in cui si trova, anche in caso che allo stelo siano applicati dei carichi.

**Stopped Cylinder**

GB

Taking away the feeding to the driving circuit the block valves lock the cylinder into the position where it is at that moment, even if at the piston are attached some loads.

**Zylinder Blockiert**

DE

Trennen Sie die Versorgung der Steuerschaltung der Stoppventile an den Zylindern, so wird eine Last (Gewicht), die auf den Kolben drückt, blockiert und in der Position gehalten.

**Vérin bloqué**

FR

En coupant le pilotage, le bloc vérin bloque la tige dans la position où elle se trouve, même sous l'effort d'une charge entrainante.

**Cilindro Bloqueado**

ES

Cortando la alimentación del circuito de pilotaje las válvulas bloquean el cilindro en la posición en la que se encuentra, incluso en el caso en que el cilindro este sometido a alguna carga.

**Cilindro Parado - Bloqueado**

PT

Cortando a alimentação do circuito de pilotagem as válvulas de bloqueio travam o cilindro na posição em que este se encontra, mesmo que existam cargas externas conectadas ao cilindro.



**Pressione di Pilotaggio**

Pressione minima del Pilota per azionare la valvola, in relazione alla pressione a monte.

**IT**

**Pilot Pressure**

Pilot minimum pressure to feed the valve compared to the inlet pressure.

**GB**

**Steuerdruck**

Minimaler Steuerdruck um das Ventil zu betätigen, in Bezug auf den Vordruck.

**DE**

**Pression de Pilotage**

Pression de pilotage minimale par rapport à la pression interne (d'utilisation).

**FR**

**Presión de Pilotaje**

Presión mínima de pilotaje para accionar la válvula, en relación a la presión de entrada.

**ES**

**Pressão de Pilotagem**

Pressão mínima do Piloto para accionar a válvula, em relação à pressão de entrada.

**PT**

**CODE: 8880**

**U**

**UNIDIREZIONALE**

UNI-DIRECTIONAL

RÜCKSCHLAG

UNI-DIRECTIONNEL

UNIDIRECCIONAL

UNIDIRECCIONAL

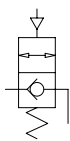

**P (bar)**

Pressione di Pilotaggio  
Pilot Pressure  
Steuerdruck  
Pression de Pilotage  
Presión de Pilotaje  
Pressão de Pilotagem

**P1 (bar)**

Pressione di entrata  
Inlet Pressure  
Eingangsdruck  
Pression d'entrée  
Presión de entrada  
Pressão de entrada

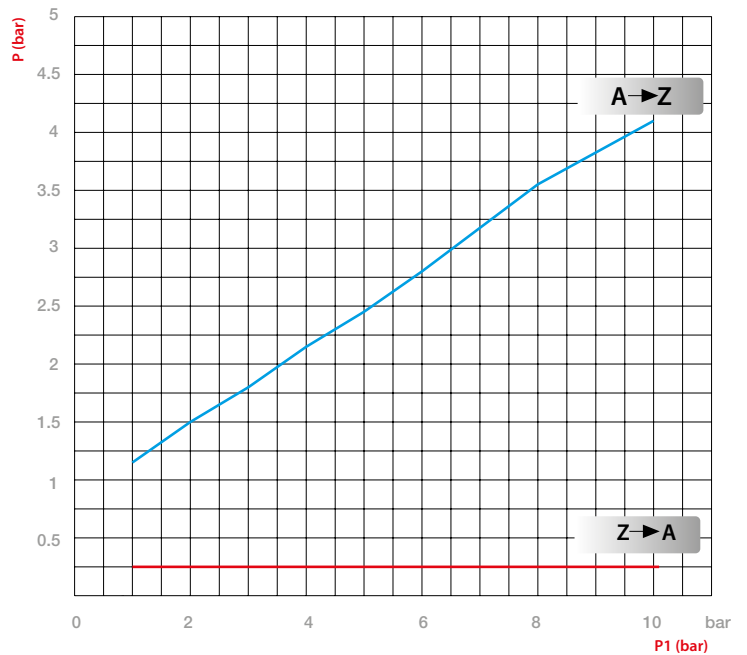
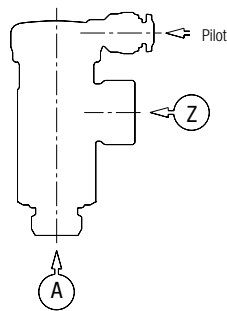

**CODE: 8890**

**B**

**BI-DIREZIONALE**

BI-DIRECTIONAL

BI-DIRECCIONAL

BI-DIRECTIONNEL

BIDIRECCIONAL

BI-DIRECCIONAL

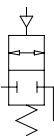

**P (bar)**

Pressione di Pilotaggio  
Pilot Pressure  
Steuerdruck  
Pression de Pilotage  
Presión de Pilotaje  
Pressão de Pilotagem

**P1 (bar)**

Pressione di entrata  
Inlet Pressure  
Eingangsdruck  
Pression d'entrée  
Presión de entrada  
Pressão de entrada

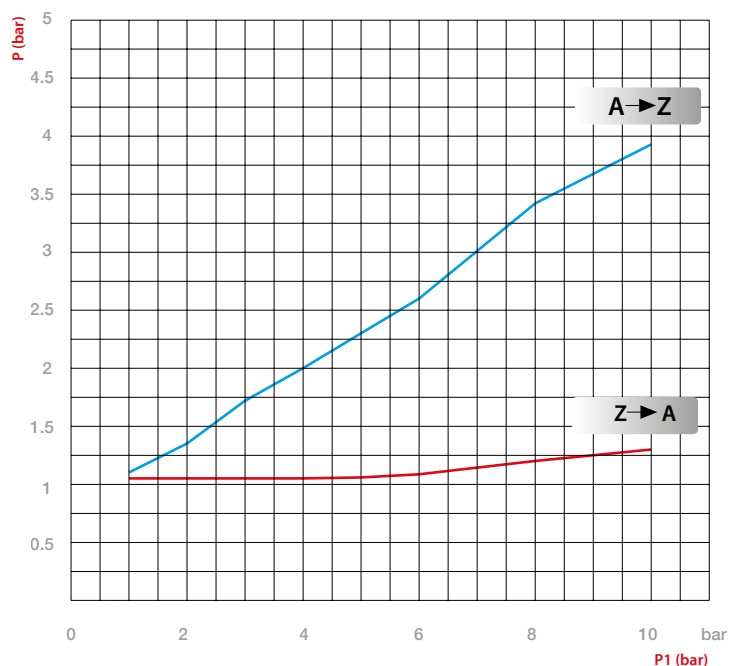
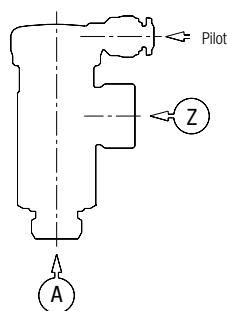



<b>Pressione di Pilotaggio</b> Curve caratteristiche di flusso	<b>IT</b>	<b>Pilot Pressure</b> Characteristic curves of flow	<b>GB</b>	<b>Steuerdruck</b> Durchflusskennlinien	<b>DE</b>
<b>Pression de Pilotage</b> Caractéristiques du débit	<b>FR</b>	<b>Presión de Pilotaje</b> Curvas características de flujo	<b>ES</b>	<b>Pressão de Pilotagem</b> Curvas características de vazão	<b>PT</b>

**CODE: 8880 - 8890**    1/8

**NI/min**

Portata d'aria Q a 0° C e 1013 mbar  
Air rate Q at 0°C and 1013 mbar  
Luftdurchlass Q bei 0° C und 1013 mbar  
Débit d'air Q à 0°C et 1013 mbar  
Caudal de Aire Q 0° C y 1013 mbar  
Vazão de ar Q 0° C e 1013 mbar

**P1 (bar)**

Pressione di entrata  
Inlet Pressure  
Eingangsdruk  
Pression d'entrée  
Presión de entrada  
Pressão de entrada

**P2 (bar)**

Pressione in uscita  
Outlet Pressure  
Eingangsdruk  
Pression de sortie  
Presión de Entrada  
Pressão de Entrada

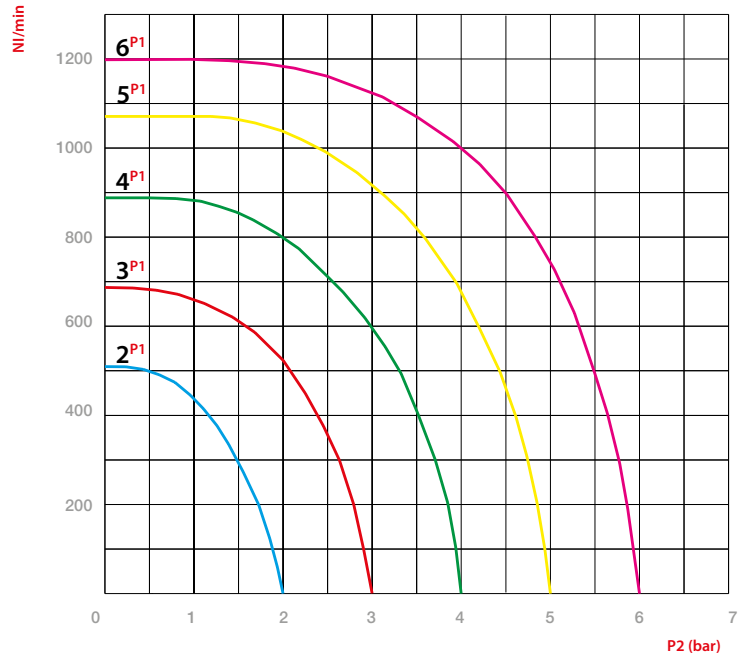

**CODE: 8880 - 8890**    1/4

**NI/min**

Portata d'aria Q a 0° C e 1013 mbar  
Air rate Q at 0°C and 1013 mbar  
Luftdurchlass Q bei 0° C und 1013 mbar  
Débit d'air Q à 0°C et 1013 mbar  
Caudal de Aire Q 0° C y 1013 mbar  
Vazão de ar Q 0° C e 1013 mbar

**P1 (bar)**

Pressione di entrata  
Inlet Pressure  
Eingangsdruk  
Pression d'entrée  
Presión de entrada  
Pressão de entrada

**P2 (bar)**

Pressione in uscita  
Outlet Pressure  
Eingangsdruk  
Pression de sortie  
Presión de Entrada  
Pressão de Entrada

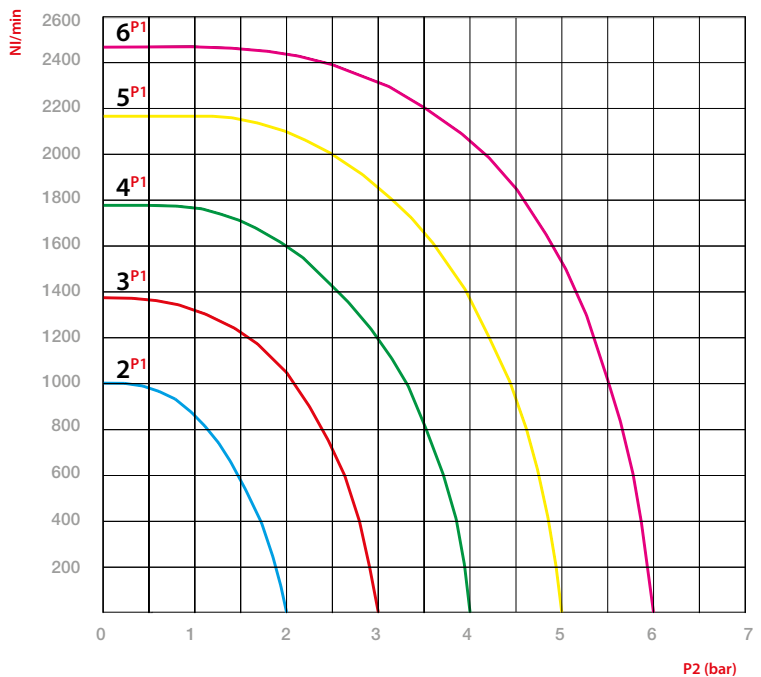

## MOLTIPLICATORE DI PRESSIONE

PRESSURE BOOSTERS  
 DRUCKÜBERSETZER  
 MULTIPLICATEURS DE PRESSION  
 MULTIPLICADORES DE PRESIÓN  
 MULTIPLICADORES DE PRESSÃO



### CARATTERISTICHE TECNICHE

TECHNICAL CHARACTERISTICS  
 TECHNISCHE ANGABEN  
 CARACTÉRISTIQUES TECHNIQUES  
 CARACTERÍSTICAS TÉCNICAS  
 CARACTERÍSTICAS TÉCNICAS



#### Materiali e Componenti

- 1 Corpo Alluminio
- 2 Pistoni Alluminio
- 3 Stelo Acciaio
- 4 Viti di fissaggio / Seger
- 5 Spole valvole
- 6 Elementi di tenuta in NBR

**IT**

#### Component Parts and Materials

- 1 Body Aluminium
- 2 Pistons Aluminium
- 3 Stem Steel
- 4 Fixing screws / Seger
- 5 Valve spools
- 6 Sealing elements in NBR

**GB**

#### Komponenten und Materialien

- 1 Gehäuse aus Aluminium
- 2 Kolben Aluminium
- 3 Kolbenstange Stahl
- 4 Befestigungsschrauben
- 5 Ventilstifte
- 6 Dichtungen aus NBR

**DE**

#### Matériaux et Composants

- 1 Corps Aluminium
- 2 Pistons en aluminium
- 3 Tiges Acier
- 4 Vis de fixation / Seger
- 5 Tirroirs de valve
- 6 Éléments d'étanchéité en NBR

**FR**

#### Materiales y Componentes

- 1 Cuerpo en Aluminio
- 2 Pistón en Aluminio
- 3 Vástago en Acero
- 4 Tornillos de fijación / Seger
- 5 Válvula de corredera
- 6 Juntas en NBR

**ES**

#### Materiais e Componentes

- 1 Corpo em Alumínio
- 2 Pistões em Alumínio
- 3 Haste em Aço
- 4 Parafusos de fixação / Anel Seger
- 5 Carretel das Válvulas
- 6 Elementos de vedação em NBR

**PT**

#### Pressione di alimentazione

Inlet pressure  
 Speisedruck  
 Pression d'alimentation  
 Presión de alimentación  
 Pressão de alimentação

**3 bar** (0,3 MPa)

**10 bar** (1 MPa)

#### Temperatura d'esercizio

Working temperature  
 Betriebstemperatur  
 Température de service  
 Temperatura de ejercicio  
 Temperatura de trabalho

**- 20 °C**
**+ 50 °C**

#### Fluidi compatibili

Aria compressa filtrata lubrificata e non lubrificata.

#### Fluids

Filtered and lubricated compressed air as well as non lubricated air.

#### Geeignete Medien

Filtered and lubricated compressed air as well as non lubricated air.

#### Fluides compatibles

Air comprimé filtré, lubrifié ou non lubrifié.

#### Fluidos compatibles

Aire comprimido filtrado lubricado y no lubricado.

#### Fluidos compatíveis

Ar comprimido filtrado e lubrificado ou não lubrificado.



#### Aspettativa di vita

Life expectancy  
 Lebensdauer  
 Durée de vie  
 Expectativa de vida  
 Expectativa de vida

**20 MILLION CYCLES**

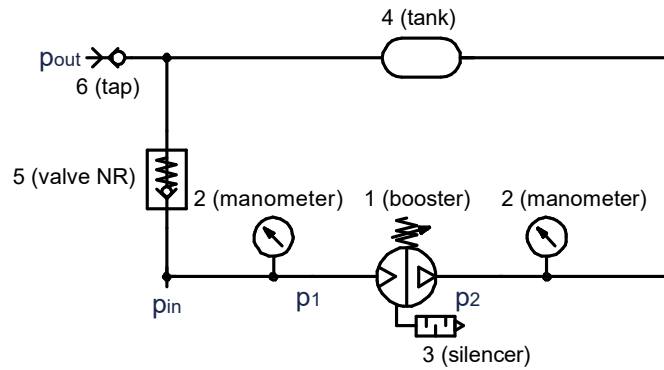

**Collegamento all'impianto**

**IT**

**Connection to the compressed air network**

**GB**

**Anschluss an das Druckluftnetz**

**DE**

Nel moltiplicatore l'erogazione del fluido ad alta pressione è di tipo "pulsante", si consiglia quindi di utilizzare sempre un serbatoio d'aria (4) all'uscita del moltiplicatore per evitare pulsazioni all'utilizzo. Un collegamento di bypass come illustrato da schema (5) è suggerito per velocizzare il primo riempimento dell'impianto. La scelta del moltiplicatore non coinvolge solo il rapporto di compressione ma soprattutto il volume del serbatoio sufficiente a garantire la corretta alimentazione degli utilizzi. Preliminarmente si deve calcolare il volume d'aria prelevato dagli utilizzi (cilindri, ugelli di soffiaggio etc..) per poi passare alla determinazione del volume del serbatoio.

The booster provides high pressure air in a "pulsating" way, therefore it is suggested to a/ways use an air tank (4) at the output of the multiplier to avoid pulsation on use. A bypass connection as shown in the diagram (5) is suggested to speed up the initial filling of the system. The choice of the booster doesn't onlv involve the compression ratio but, most al/ it involves the tank volume that as to be enough to guarantee the correct feeding of the uses. First of al/ it is necessary to calculate the volume of air taken from the uses (cylinders, blowing nozz/es etc...) and then move on to the determination of the tank volume.

Der Druckverstärker liefert pulsierend Luft unter hohem Druck, daher wird empfohlen, einen Luftbehälter (4) am Ausgang des Verstärkers zu verwenden, um eine Pulsation zu vermeiden. Eine Bypass-Verbindung, wie im Diagramm (5) gezeigt, wird empfohlen, um die Inbetriebnahme des Systems zu beschleunigen. Die Wahl des Verstärkers hat nichts mit dem Verdichtungsverhältnis zu tun, sondern, vor allem mit dem Tankvolumen, das ausreichend sein muss um die korrekte Versorgung der Verbraucher zu gewährleisten. Zunächst ist es notwendig, das von den Verbrauchern erforderliche Luftvolumen zu berechnen (Ventilatoren, Blasdüsen usw.) um danach das Tankvolumens zu bestimmen.

Il moltiplicatore di pressione entra automaticamente in funzione appena si applica una pressione in ingresso (P1) e lavora fino a che la pressione in uscita (P2) raggiunge il doppio di quella in ingresso (con rapporto di compressione 1:2), il triplo (con rapporto di compressione 1:3), il quadruplo (con rapporto di compressione 1:4). Il booster non è concepito per lavorare a scarico libero, ma prevede sempre un utilizzo collegato. La pressione in uscita può eventualmente essere regolata tramite un riduttore di pressione. Quando non viene prelevata aria in uscita, la presenza delle valvole di non ritorno integrate permette di mantenere la pressione moltiplicata anche in assenza di pressione in ingresso.

The pressure multiplier starts automatically as soon as an input pressure (P1) is applied and works until the output pressure (P2) reaches twice the input pressure (with a compression ratio of 1:2), the triple (with compression ratio 1:3), the quadruple (with compression ratio 1:4). The booster is not designed to work with free discharge, but always provides a connected use. The outlet pressure can be adjusted by means of a pressure reducer. When no outlet air is drawn, the presence of integrated non-return valves allows the multiplied pressure to be maintained even in the absence of inlet pressure.

Der Druckübersetzer arbeitet automatisch, sobald ein Eingangsdruck (P1) ansteht und arbeitet, bis der Ausgangsdruck (P2) das Doppelte des Eingangsdrucks erreicht zweifache (mit Verdichtungsverhältnis 1:2), dreifache (mit Verdichtungsverhältnis 1:3) vierfache (mit Verdichtungsverhältnis 1:4). Der Ausgangsdruck kann über einen Druckminderer geregelt werden. Wenn am Ausgang keine Luft angesaugt wird, ermöglichen die integrierten Rückschlagventile die Aufrechterhaltung des Drucks.

**Raccordement au réseau d'air comprimé**

**FR**

**Conexión a la red de aire comprimido**

**ES**

**Conexão com a planta**

**PT**

Le surpresseur fournit de l'air à haute pression de manière "pulsée", il est donc suggéré d'utiliser un réservoir d'air (4) à la sortie du multiplicateur pour éviter les fluctuations à l'utilisation. Une dérivation comme indiqué sur le schéma (5) est recommandée pour accélérer le démarrage/remplissage du système. Le choix seul du multiplicateur n'implique pas le taux de compression mais, également le volume du réservoir doit être suffisant pour garantir l'alimentation correcte. Il est nécessaire de calculer le volume d'air utile sur l'installation (nombre de vérins, buses de soufflage, ecc... puis de définir le volume du réservoir.

En el multiplicador la entrega del fluido de alta presión es del tipo pulsador, por lo que se recomienda siempre utilizar un depósito de aire (4) en la salida del multiplicador para evitar variaciones durante el uso. Se sugiere la conexión bypass como se ilustra en el diagrama (5) para acelerar el primer llenado del sistema. La elección del multiplicador no solo implica la relación de compresión, también el volumen del depósito suficiente para asegurar un correcto funcionamiento del circuito. Primero debemos calcular el volumen de aire necesario de los elementos (cilindros, boquillas de soplado, etc...) y luego determinar el volumen del depósito.

No multiplicador fornece alta pressão do tipo "pulsante", e é aconselhável utilizar sempre um reservatório de ar (4) na saída do multiplicador para evitar pulsação na utilização. Uma ligação de by-pass como ilustrado no esquema (5) é sugerida para acelerar o primeiro preenchimento da tubulação. A escolha do multiplicador não envolve apenas a taxa de compressão, mas acima de tudo o volume do tanque, que deve ser suficiente para garantir o abastecimento correto da aplicação. Preliminarmente, se tiver que calcular o volume de ar necessário para a aplicação (cilindros, bicos de sopro, etc...) e, em seguida, passar para a determinação do volume do tanque.

Le multiplicateur de pression se déclenche automatiquement dès que vous appliquez une pression d'entrée (P1) et fonctionne jusqu'à ce que la pression de sortie (P2) atteigne le double de celle d'entrée (avec un taux de compression de 1:2), le triple (avec un taux de compression de 1:3), le quadruple (avec un taux de compression de 1:4). Le booster n'est pas conçu pour fonctionner à décharge libre, mais prévoit toujours une utilisation connectée. La pression de sortie peut éventuellement être réglée par un détendeur. Lorsqu'aucun air de sortie n'est prélevé, la présence des clapets anti-retour intégrés permet de maintenir la pression multipliée même en l'absence de pression d'entrée.

El multiplicador de presión entra automáticamente en funcionamiento tan pronto como se aplica una presión en la entrada (P1) y trabaja hasta que la presión de salida (P2) llega al doble de la entrada (relación de compresión 1:2), triple (relación de compresión 1:3), o cuádruple (relación compresión 1:4). El multiplicador no está concebido para trabajar a escape libre, se debe prever siempre un uso conectado. La presión de salida puede ser ajustada usando un regulador de presión. Cuando no se utiliza aire de salida las válvulas de retención integradas permiten mantener la presión en el multiplicador incluso en ausencia de presión en la entrada.

O multiplicador de pressão entra automaticamente em funcionamento assim que uma pressão é aplicada na entrada (P1) e trabalha até que a pressão de saída (P2) atinja o dobro da pressão de entrada (com taxa de compressão 1:2), triplo (com taxa de compressão de compressão 1:3), quádruplo (com uma taxa de compressão de 1:4). O booster não foi projetado para funcionar com saída livre para atmosfera e é sempre previsto o uso conectado a um sistema. A pressão de saída pode eventualmente ser ajustada através de um redutor de pressão. Quando não há saída de ar, a presença de válvulas anti-retorno integradas permite manter a pressão multiplicada, mesmo na ausência de pressão de entrada.



Vantaggi principali	IT	Main advantages	GB	Hauptvorteile	DE
<p>Il moltiplicatore di pressione serve ad aumentare la pressione fornita dal compressore a spese di una perdita di portata proporzionale. Non sostituiscono quindi un compressore ma forniscono per un tempo limitato una pressione di un valore superiore. Normalmente vengono impiegati per incrementare la forza di cilindri pneumatici, mantenendo ingombri e pesi più contenuti, per soffiaggi ad alta pressione, per collaudi di componenti, per prove di scoppio, ecc...</p> <p>Applicazione: Impianti aria compressa e strumentazione, Automazione pneumatica e fluidica, Macchine lavorazione legno, Macchine per stampaggio, Prodotti standard, Rapporto di compressione 1-2, Sistemi di saldatura, trasporti.</p>		<p><i>Pressure boosters serve to increase the pressure supplied by the compressor at the expense of a proportional flow loss. Therefore they don't replace a compressor but provide a pressure of a higher value for a limited time. They are normally used to increase the strength of pneumatic cylinders, keeping smaller overall dimensions and weights, for blowing at high pressure, for testing components, for bust test, etc...</i></p> <p>Application: Compressed air and instrumentation systems, Pneumatic and fluid automation, Woodworking machines, Moulding machines, Standard products, Compression ratio 1-2, Welding systems, transport.</p>		<p><i>Druckverstärker dienen der Erhöhung des vom Kompressor gelieferten Betriebsdruck für einen bestimmten Anlagenteil. Sie ersetzen also nicht den Kompressor, sondern stellen für eine begrenzte Zeit einen höheren Druck zur Verfügung. Sie werden normalerweise verwendet, um die Kraft von Pneumatik Zylinder zu erhöhen und dabei kleinere Abmessungen und Gewichte beizubehalten, oder für Blasanwendungen mit hohem Druck und viele weitere...</i></p> <p>Anwendung: Druckluft- und Instrumentierungssysteme, Pneumatik und Fluid-Automation, Holzbearbeitungsmaschinen, Gießereimaschinen, Maschinen, Standardprodukte, Verdichtungsverhältnis 1-2, Schweißanlagen, Transport.</p>	
Principaux avantages	FR	Principales ventajas	ES	Vantagens principais	PT
<p><i>Les multiplicateurs de pression servent à augmenter la pression fournie par le compresseur au détriment d'une perte de débit proportionnelle. Ils ne remplacent donc pas un compresseur mais ils assurent une pression d'une valeur supérieure dans un temps limité.</i></p> <p><i>Ils sont généralement utilisés pour augmenter la force des vérins pneumatiques, en maintenant les dimensions globales et des poids plus légers. Pour le soufflage à haute pression, pour des tests de composants, pour des tests d'éclatement, etc...</i></p> <p>Application: Systèmes d'air comprimé et instrumentation, Automatisation pneumatique et fluïdique, Machines pour travail du bois, presses, taux de compression 1-2, systèmes de soudage, transport.</p>		<p><i>El multiplicador de presión sirve para aumentar la presión suministrada por el compresor a expensas de una pérdida de caudal proporcional. No reemplaza a un compresor, pero proporciona por un tiempo limitado una presión de valor superior. Suelen utilizarse para aumentar la fuerza de los cilindros neumáticos, manteniendo las dimensiones generales y pesos más ligeros, para soplado a alta presión, para ensayo de componentes, para pruebas de presión de rotura, etc...</i></p> <p>Aplicaciones: Instalaciones de aire comprimido e instrumentación, automatización neumática y de fluidos, máquinas para madera, máquinas de estampación, productos estándar, relación de compresión 1-2, sistemas de soldadura, transporte.</p>		<p><i>O multiplicador de pressão serve para aumentar a pressão fornecida pelo compressor através de uma perda de vazão proporcional. Desta forma, ele não substitui um compressor, mas fornece por um tempo limitado uma pressão de um valor superior. Normalmente são aplicados para aumentar a força de cilindros pneumáticos (mantendo menores dimensões e pesos), para sopros de alta pressão, para testes de componentes, para testes de ruptura, etc...</i></p> <p>Aplicações: Redes de ar comprimido e instrumentação, Automação pneumática e fluídica, Máquinas de trabalho com lenha, Máquinas para estampanaria, Produtos padrão, Relatório de compressão 1-2, Sistemas de solda, transportes.</p>	

**EXAMPLE:**

**Caratteristiche di carica - Ø 40 mm - 12 BS00104012**  
**Charging characteristics - Ø 40 mm - 12 BS00104012**

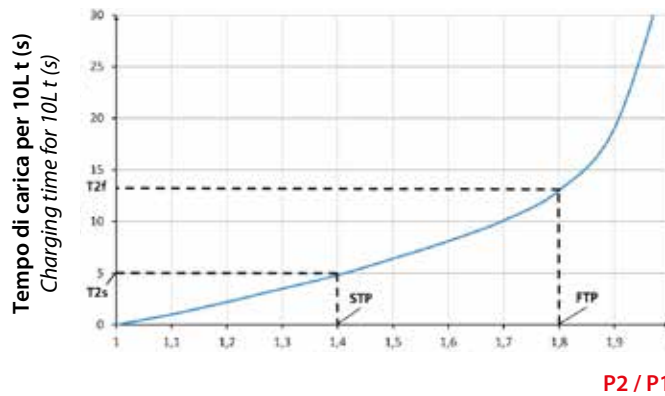

**Istruzioni per il calcolo del serbatoio**

Esempio di calcolo del tempo di riempimento di un serbatoio da 50 litri ad una pressione iniziale di 7 bar che deve essere portata a 9 bar con un moltiplicatore BS00104012 alimentato con una pressione di rete di 5 bar.

- Pressione di alimentazione: P1 = 5 bar;
- Pressione iniziale serbatoio bar: STP = 7;
- Pressione finale serbatoio: FTP = 9 bar;
- Volume serbatoio: V = 50 L.

- 1 Calcolare STP/P1 e FTP/P1;
- 2 Ricavare dal grafico relativo al moltiplicatore i valori del tempo;
- 3 Il tempo di riempimento di un serbatoio da 10 litri con le pressioni iniziali e finali di cui sopra è  $t = T2f - T2s$ ;
- 4 Il tempo di riempimento di un serbatoio da 50 litri è  $Ttot = t * V / 10$ .

**IT Tank calculation instruction**

Calculation example about filling time of a 50 litres volume tank from starting pressure of 7 bar to final pressure of 9 bar using a pressure intensifier BS00104012 with a inlet pressure of a 5 bar.

- Inlet pressure: P1 = 5 bar;
- Starting tank pressure: STP = 7;
- Final tank pressure: FTP = 9 bar;
- Tank volume: V = 50 L.

- 1 Calculate STP/P1 and FTP/P1;
- 2 Get in the chart the time values corresponding to the graphic;
- 3 The filling time of a 10 litres tank with initial and final pressure above indicated is  $t = T2f - T2s$ ;
- 4 The filling time of a 50 litres tank is  $Ttot = t * V / 10$ .

**GB Berechnungsbeispiel Tank Füllzeit**

Berechnungsbeispiel für die Füllzeit eines 50-Liter-Tanks Behälters von einem Startdruck von 7 bar auf einen Enddruck von 9 bar unter Verwendung eines Druckmessgerätes BS00104012 mit einem Eingangsdruck von 5 bar.

- Eingangsdruck: P1 = 5 bar.
- Anfangsdruck des Tanks: STP = 7;
- Tankdruck: FTP = 9 bar;
- Tankvolumen: V = 50 L.

- 1 Berechnen Sie STP/P1 und FTP/P1;
- 2 Holen Sie sich in der Tabelle die Zeitwerte, aus der Grafik;
- 3 Die Füllzeit für einen 10-Liter-Tank mit dem oben angegebenen Anfangs- und Enddruck ist  $t = T2f - T2s$ ;
- 4 Die Füllzeit für einen 50-Liter-Tank ist  $Ttot = t * V / 10$ .

**FR Instructions de calcul du réservoir**

Exemple de calcul du temps de remplissage d'un réservoir de 50 litres à une pression initiale de 7 bar qu'il faut porter à 9 bar avec un multiplicateur BS00104012 fourni avec une pression réseau de 5 bar.

- Pression d'alimentation: P1 = 5 bars ;
- Pression initiale du réservoir bar: STP = 7 ;
- Pression finale réservoir: FTP = 9 bar ;
- Volume du réservoir: V = 50 L.

- 1 Calculez STP/P1 et FTP/P1;
- 2 Prendre dans l'abaque les valeurs de temps relatives au multiplicateur;
- 3 Le temps de remplissage d'un réservoir de 10 litres avec les pressions initiale et finale ci-dessus sont  $t = T2f - T2s$ ;
- 4 Le temps de remplissage d'un réservoir de 50 litres est  $Ttot = t * V / 10$ .

**ES Instrucciones para el cálculo del depósito**

Ejemplo de cálculo del tiempo de llenado de un depósito de 50 litros a una presión inicial de 7 bar que debe llevarse a 9 bar con un multiplicador BS00104012 suministrado con una presión de red de 5 bar.

- Presión de alimentación: P1 = 5 bar;
- Presión inicial depósito bar: STP=7 bar;
- Presión final depósito: FTP = 9 bar;
- Volumen depósito: V = 50 L.

- 1 Calcular STP/P1 y FTP/P1;
- 2 Obtener en el gráfico los valores de tiempo correspondientes;
- 3 El tiempo de llenado de un depósito de 10 litros con las presiones inicial y final anteriores son  $t = T2f - T2s$ ;
- 4 El tiempo de llenado de un depósito de 50 litros es  $Ttot = t * V / 10$ .

**PT Cálculo de tempo enchimento de reservatório**

Exemplo de cálculo de tempo de enchimento de um reservatório de 50 litros a uma pressão inicial de 7 bar que deve ser elevada a 9 bar com um multiplicador BS00104012 alimentado com uma pressão de rede de 5 bar.

- Pressão de alimentação: P1 = 5 bar;
- Pressão inicial reservatório : STP = 7bar
- Pressão final reservatório: FTP = 9 bar;
- Volume reservatório: V = 50 L

- 1 Calcular STP/P1 e FTP/P1;
- 2 Encontrar no gráfico relativo ao multiplicador os valores de tempo;
- 3 O tempo de enchimento de um reservatório de 10L com pressões iniciais e finais indicado abaixo é  $t = T2f - T2s$ ;
- 4 O tempo de enchimento de um reservatório de 50L é  $Ttot = t * V / 10$ .



**Tabella dei codici di ordinazione**

- Ordering codes
- Bestellschlüssel
- Code de commande
- Tabla de codificación para pedidos
- Tabela de codificação para compra

SERIE	Ø	Rapporto di compressione Pressure ratio Druckverhältnis Rapport de compression Ratio de compresión Taxa de Compressão
<b>BS001</b>	<b>040</b>	<b>1 2</b>
	040 = 40 mm	12 = OUT Pmax = 20 bar (Standard)
	063 = 63 mm	
	100 = 100 mm	13 = OUT Pmax = 30 bar (13 On request)

**Caratteristiche di carica - Ø 40 mm - 12**  
*Charging characteristics - Ø 40 mm - 12*

**BS00104012 - Ø 40 mm**

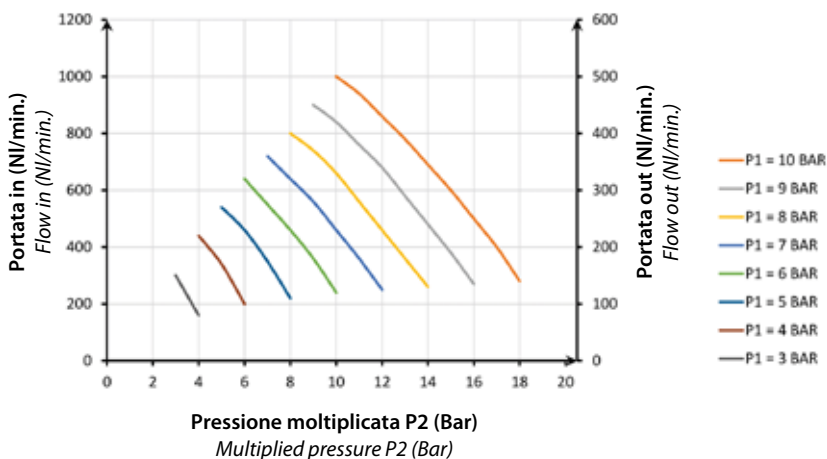
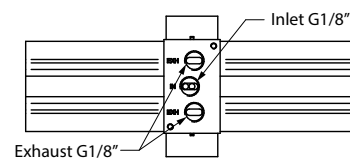
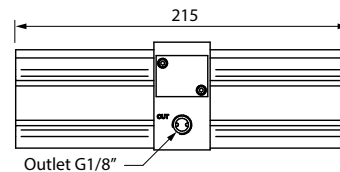
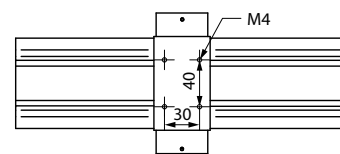
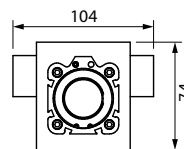
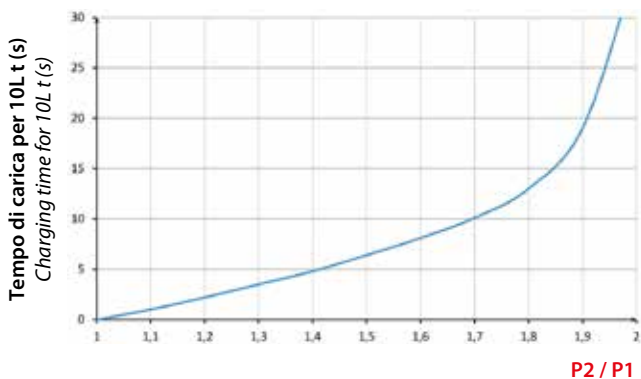

**Caratteristiche di carica - Ø 63 mm - 12**  
*Charging characteristics - Ø 63 mm - 12*

**BS00106312 - Ø 63 mm**

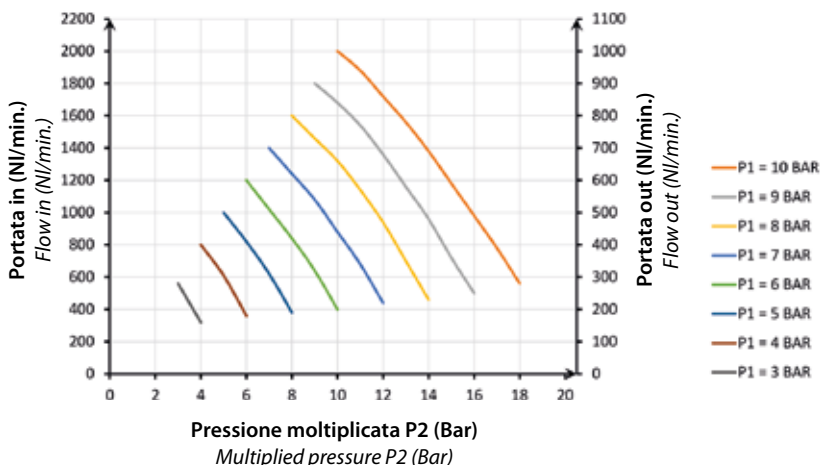
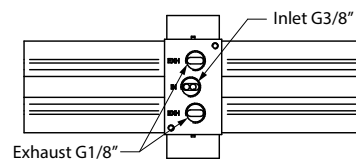
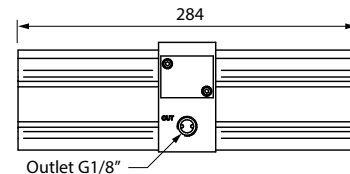
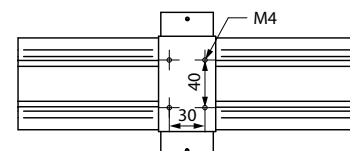
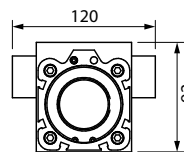
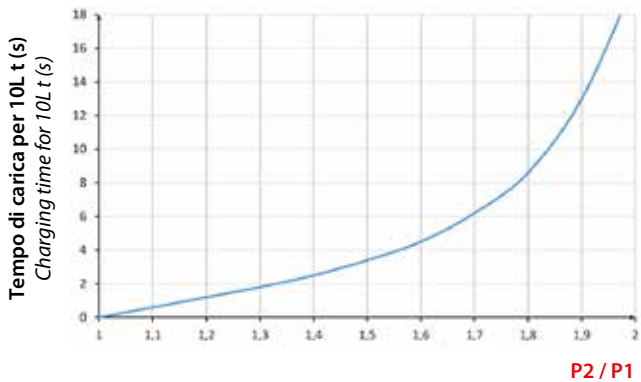

Caratteristiche di carica - Ø 100 mm - 12  
Charging characteristics - Ø 100 mm - 12

**BS00110012 - Ø 100 mm**

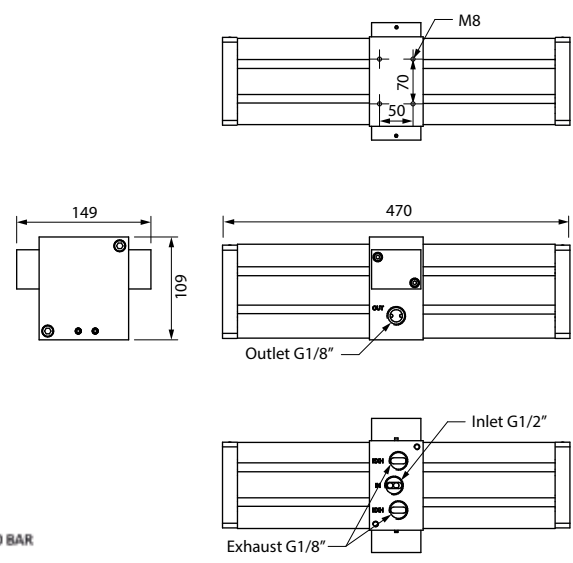
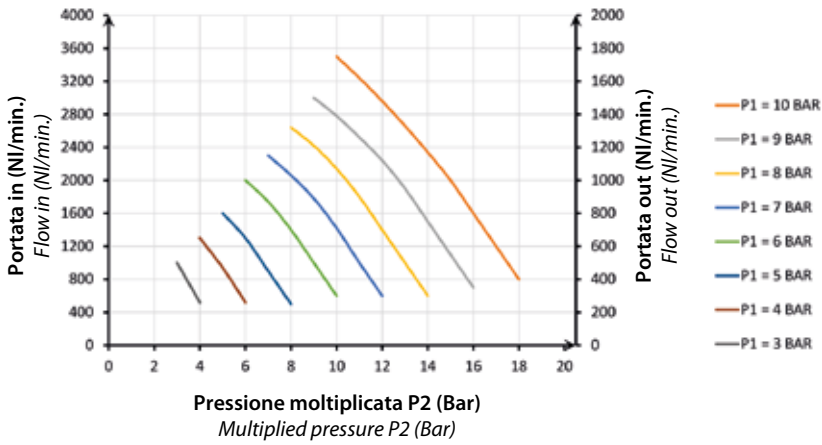
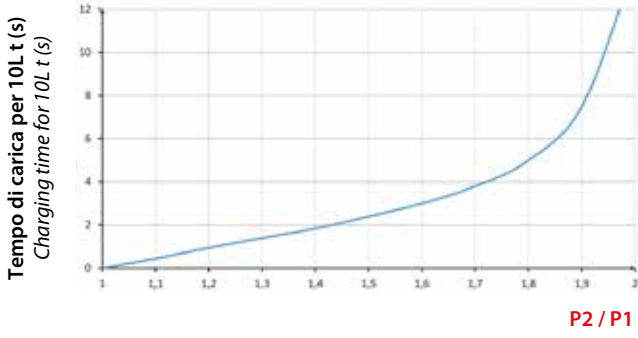

**Caratteristiche di carica - Ø 40 mm - 13**  
 Charging characteristics - Ø 40 mm - 13

**BS00104013 - Ø 40 mm / On request**

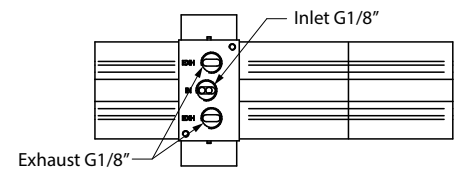
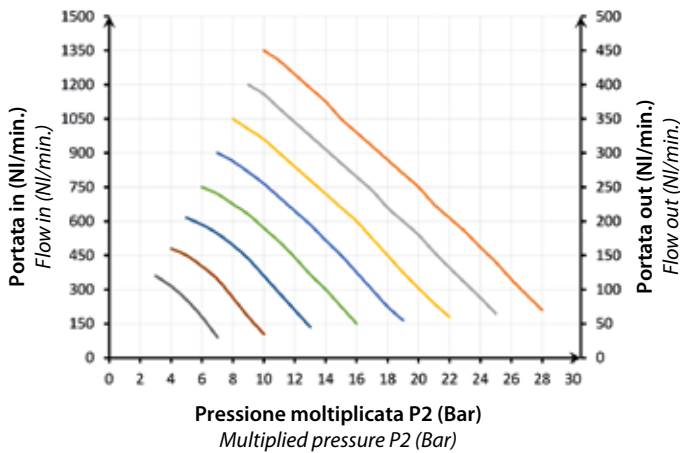
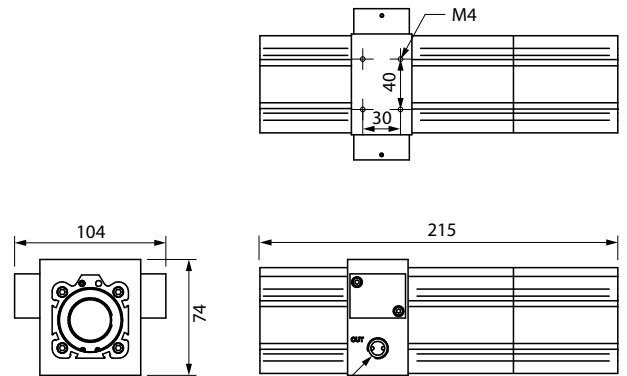
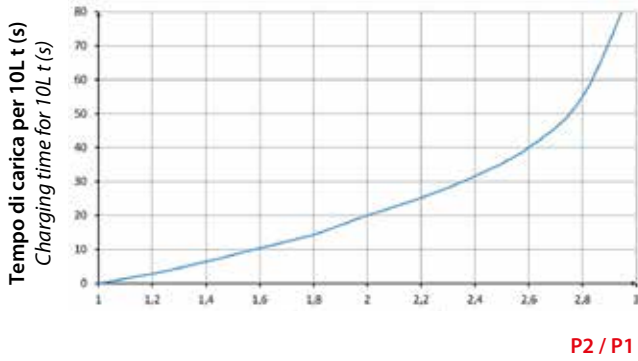

**Caratteristiche di carica - Ø 63 mm - 13**  
 Charging characteristics - Ø 63 mm - 13

**BS00106313 - Ø 63 mm / On request**

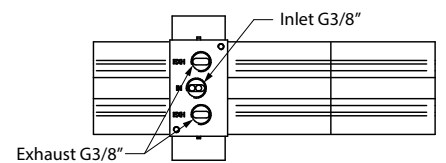
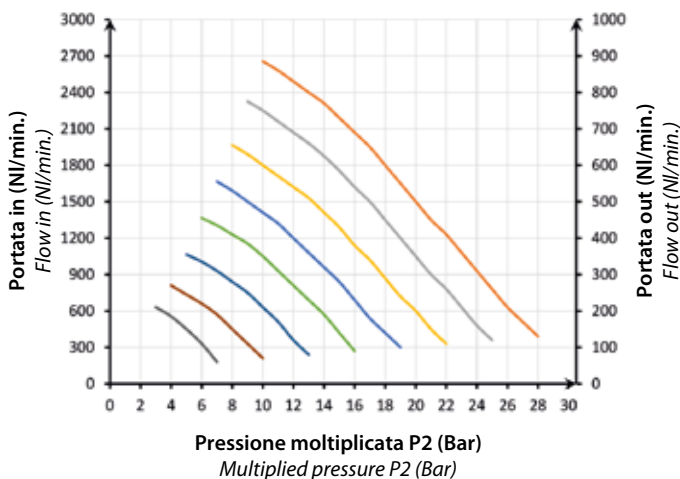
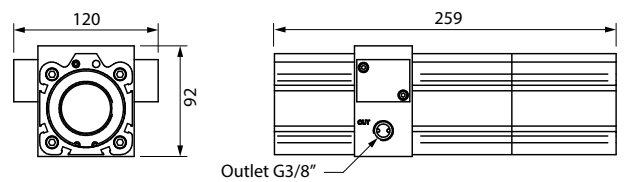
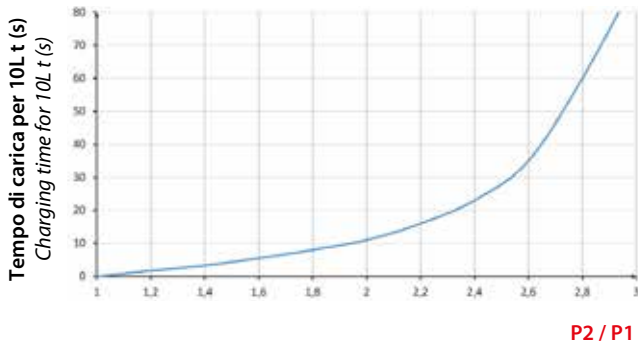

**Caratteristiche di carica - Ø 100 mm - 13**  
 Charging characteristics - Ø 100 mm - 13

**BS00110013 - Ø 100 mm / On request**

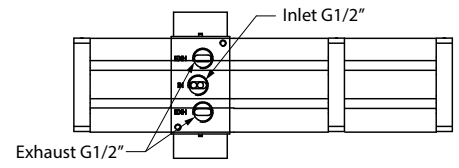
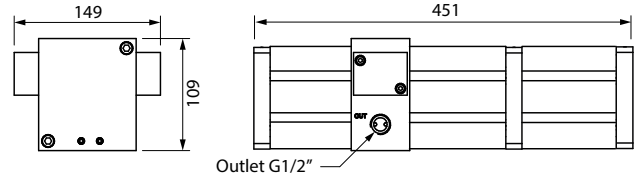
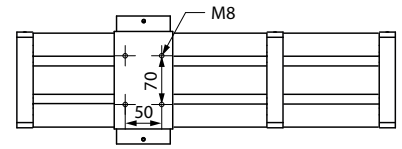
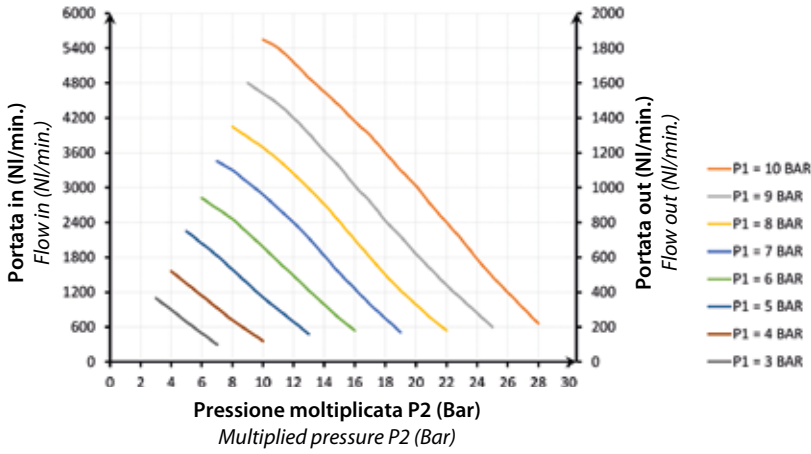
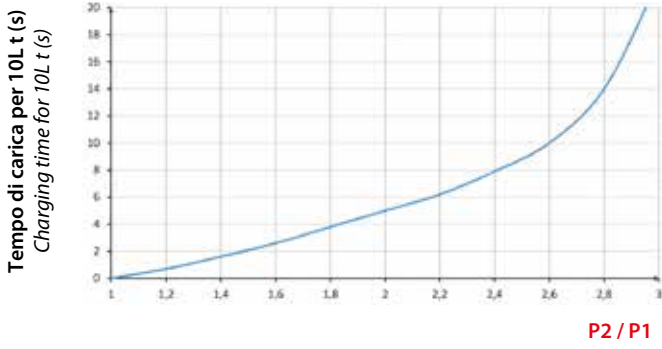

**COMPONENTI DI FISSAGGIO PER BS001**

FIXING ACCESSORIES FOR BS001  
 BEFESTIGUNGSMATERIAL FÜR BS001  
 ACCESSOIRES DE FIXATION POUR BS001  
 COMPONENTES DE FIJACIÓN PARA BS001  
 COMPONENTE DE FIXAÇÃO PARA BS001

**VCA**

**PIEDINO ALTO**  
 HIGH RISE PEDESTAL  
 HOHER FUSS  
 PIED HAUT  
 PIE ALTO  
 PÉS DE ALTO PERFIL

**BS00104012 - Ø40 mm**

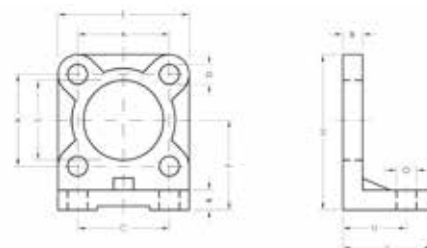

Code	A	B	C	D	E	F	M	O	S	U	V
<b>VCA 040</b>	38	8	36	7	52	36	62	9	35	28	35

**BSCP**

**PIEDINO BASSO**  
 LOW-RISE PEDESTAL  
 FUSSBEFESTIGUNG  
 EQUERRE DE FIXATION  
 PATA  
 PÉS DE BAIXO PERFIL

**BS00106312 - Ø63 mm**

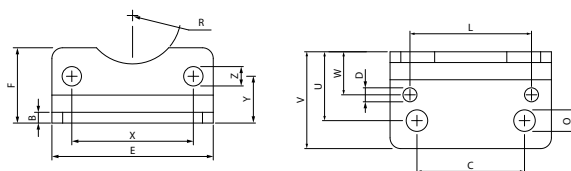

Code	B	C	E	F	O	U	V	R	Z	X	Y	D	L	W
<b>BSCP 063</b>	5	50	75	35	10	32	45	22.5	9	56.5	21.75	6.5	56.5	20

**BSCP**

**PIEDINO BASSO**  
 LOW-RISE PEDESTAL  
 FUSSBEFESTIGUNG  
 EQUERRE DE FIXATION  
 PATA  
 PÉS DE BAIXO PERFIL

**BS00110012 - Ø100 mm**

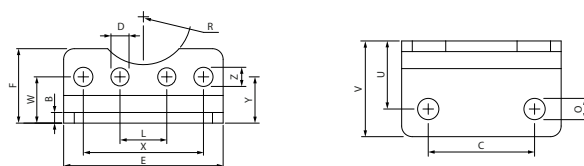

Code	B	C	E	F	O	U	V	R	Z	X	Y	D	L	W
<b>BSCP 100</b>	5	50	75	35	10	32	45	22.5	9	56.5	21.75	8.5	22	22

**VALVOLA COASSIALE DI INTERCETTAZIONE**

COAXIAL VALVE  
PNEUMATISCHES AXIALVENTIL  
VANNE D'ARRÊT  
VÁLVULA DE CIERRE  
VÁLVULA DE INTERCEPTAÇÃO



**CARATTERISTICHE TECNICHE**

TECHNICAL CHARACTERISTICS  
TECHNISCHE ANGABEN  
CARACTÉRISTIQUES TECHNIQUES  
CARACTERÍSTICAS TÉCNICAS  
CARACTERÍSTICAS TÉCNICAS



**Norma di Riferimento**

Reference standard

Entspricht der Norm

Norme de référence

Normativa de referencia

Norma de referência

1907/2006



2011/65/CE



PED

2014/68/UE

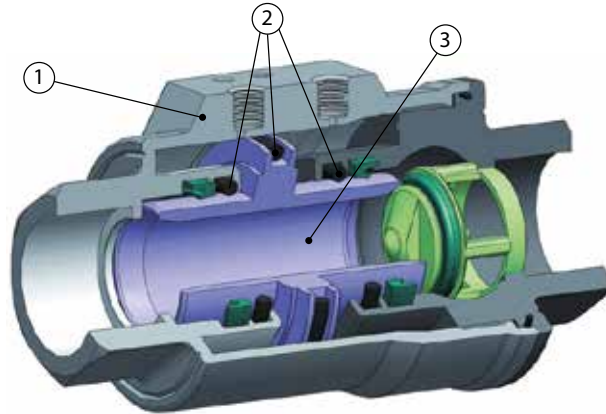

Fino ad esaurimento scorte  
Until the end stock  
Nur solange vorrat  
Livrable jusqu'à épuisement du stock  
Hasta fin de stock  
Ate fim do stock

Materiali e Componenti	IT	Component Parts and Materials	GB	Komponenten und Materialien	DE
1 Corpo in Ottone nichelato		1 Nickel-plated Brass Body		1 Körper Messing vernickelt	
2 Guarnizioni in FKM (EPDM o NBR su richiesta)		2 FKM Seals (EPDM or NBR upon request)		2 Dichtung aus FKM (EPDM oder NBR auf anfrage)	
3 Pistone in Ottone nichelato		3 Nickel-plated Brass Piston		3 Kolben Messing vernickelt	

Matériaux et Composants	FR	Materiales y Componentes	ES	Materiais e Componentes	PT
1 Corps: laiton nickelé		1 Cuerpo en latón niquelado		1 Corpo em Latão Niquelado	
2 Joint en FKM (EPDM ou NBR sur demande)		2 Junta en FKM (EPDM o NBR bajo demanda)		2 Vedação em FKM (EPDM ou NBR sob encomenda)	
3 Piston: laiton nickelé		3 Pistón en latón niquelado		3 Êmbolo em Latão Niquelado	



**Pressione**

Maximum

Druckbereich

Pressions

Presiones

Pressões

**-0.99 bar** (-0,099 MPa)

**10 bar** (1 MPa)



**Pressione di comando**

Operating pressure

Betriebsdruck

Pression de service

Presión de ejercicio

Pressão de operação

**\* 4.2 bar** (0.42 MPa) **Min**

**8 bar** (0.8 MPa) **Max**

\* 3 bar a doppio effetto  
3 bar with double acting  
3 bar mit Doppeltwirkend

3 bar avec double effet  
3 bar sin doble efecto  
3 bar com Dupla Ação



**Temperature di comando**

Operating Temperatures

Betriebstemperaturen

Températures de service

Temperaturas de ejercicio

Temperaturas de operação

**0 °C**

**+ 80 °C**

(-20 °C con aria secca)  
(-20 °C with dry air)  
(-20 °C mit trockener Luft)  
(-20 °C avec air sec)  
(-20 °C con aire seco)  
(-20 °C com ar seco)



**Temperature fluido intercettato**

Fluid temperature intercepted

Flüssigkeitstemperatur abgefangen

Température du fluide interceptée

Temperatura del fluido interceptado

Temperatura do fluido interceptado

**FKM**

**- 20 °C**

**+ 150 °C**

**EPDM**

**- 20 °C**

**+ 150 °C**

**NBR**

**- 20 °C**

**+ 80 °C**



**Fluidi compatibili**

Fluids

Geeignete Medien

Fluides compatibles

Fluidos compatibles

Fluidos compatíveis

**FKM**

Fluidi in genere, no vapore

Fluids in general, no steam

Medien im Allgemeinen, kein dampf

Fluides courants, no vapore

Fluidos en general, no vapor

Fluidos em geral, não vapor

**\*EPDM**

Acqua calda, vapore

Hot water, steam

Heißes Wasser, dampf

Eau chaude, vapore

Agua caliente, vapor

Água quente, vapor

**\*NBR**

Aria, gas, olii, acqua, ecc.

Air, gas, oils, water, ecc.

Luft, gas, öl, wasser, ecc.

Air, gaz, huile, eau, ecc.

Aire, gas, aceite, agua, ecc.

Ar, óleo, gás, água, ecc.

\*A richiesta. - Available upon request. - Auf Anfrage. - Sur demande. - Bajo demanda. - Sob encomenda.



<b>Filettatura</b>	<b>IT</b>	<b>Threads</b>	<b>GB</b>	<b>Gewindearten</b>	<b>DE</b>
Gas conforme ISO 7.1, BS 21, DIN 2999.		Gas in conformity with ISO 7.1, BS 21, DIN 2999.		Gewinde nach Norm ISO 7.1, BS 21, DIN 2999.	

<b>Filetages</b>	<b>FR</b>	<b>Roscas</b>	<b>ES</b>	<b>Roscas</b>	<b>PT</b>
Filetage conforme: ISO 7.1, BS 21, DIN 2999.		Gas conforme ISO 7.1, BS 21, DIN 2999.		Gas conforme ISO 7.1, BS 21, DIN 2999.	



<b>Vantaggi principali</b>	<b>IT</b>	<b>Main advantages</b>	<b>GB</b>	<b>Hauptvorteile</b>	<b>DE</b>
<p>Perdite di flusso ridotte grazie al pieno passaggio.                      Funzionamento indipendente dalla pressione del circuito principale.                      Compatibilità con numerosi fluidi, pressioni e temperature.                      Non ci sono movimenti esterni alla valvola.                      Installazione semplice e veloce, valvola con attuatore già incorporato.                      Predisposizione alla modifica del funzionamento da NC a NO e a doppio effetto.</p> <p>Rispetto al classico rubinetto con attuatore:                      Costo inferiore - Dimensioni ridotte del 50% - Azionamenti 15 volte maggiori - Nelle applicazioni a semplice effetto la posizione è sicura e garantita con meno forza richiesta.</p> <p>Applicazione:                      Impianti aria compressa e strumentazione, Automazione pneumatica e fluidica, Life &amp; sciences, Automotive, Circuiti acqua industriale.</p>		<p><i>Less loss of flow thanks to the unobstructed passage.                      Functioning is independent from the main circuit pressure.                      Full compatibility with different fluid, pressure and temperatures.                      No external movement outside of the valve.                      Easy and fast install, actuator is incorporated.                      Easier Function modifying from NC to NO and double effect.</i></p> <p><i>Compared to a valve with actuator:                      Cheaper – Dimension are reduced of 50% - Electric Drives are 15-folded – In single effect application the position is secured and granted with less force.</i></p> <p>Application:                      Compressed air plant and machinery, hydraulic and pneumatic automation, Life &amp; Science, Automotive, Automotive, Industrial water circuits.</p>		<p><i>Weniger Druckabfall dank vollem Durchfluss.                      Die Funktion ist unabhängig vom Hauptkreislauf.                      Volle Kompatibilität mit verschiedenen Flüssigkeiten, Druck und Temperaturen.                      Keine externe Bewegung ausserhalb des Ventils.                      Einfache und schnelle Installation mit integriertem Antrieb.                      In drei Ausführungen erhältlich : NC, NO und Doppelleffekt</i></p> <p><i>Im Vergleich zu einem Ventil mit externem Antrieb:                      Günstiger: die Abmessungen werden um 50 % reduziert.                      Lebensdauer ist 15-fach erhöht – bei der einfachwirkenden Ausführung ist die Position sicher und garantiert weniger Kraftaufwand.</i></p> <p>Anwendungsbereiche:                      Druckluftanlagen und –maschinen, hydraulische und pneumatische Automatisierung, Life &amp; Sciences, Automotive und industrielle Kühlkreise</p>	

<b>Principaux avantages</b>	<b>FR</b>	<b>Principales ventajas</b>	<b>ES</b>	<b>Vantagens principais</b>	<b>PT</b>
<p><i>Moins de perte de débit grâce au passage dégagé.                      Le fonctionnement est indépendant de la pression du circuit principal.                      Compatibilité totale avec différents fluides, pressions et températures.                      Pas de mouvement externe à l'extérieur de la vanne.                      Installation facile et rapide, l'actionneur est incorporé.                      Fonction plus facile de modifier de NC à no et double effet.</i></p> <p><i>Par rapport à une vanne avec actionneur:                      Moins cher-la dimension sont réduits de 50%-les entraînements électriques sont 15-fois-en application à effet unique la position est sécurisée et accordée avec moins de force.</i></p> <p>Application:                      Usine et machines d'air comprimé, automatisation hydraulique et pneumatique, Life &amp; sciences, automobile, automobile, circuits d'eau industriels.</p>		<p><i>Pérdida de flujo reducido gracias al paso total.                      Funcionamiento independiente de la presión del circuito principal.                      Compatibilidad con numerosos fluidos, presiones y temperaturas.                      No hay movimientos externos en la válvula.                      Instalación simple y veloz, válvula con actuador ya incorporado.                      Preparado para modificar el funcionamiento de NC a NA y a doble efecto.</i></p> <p><i>Respecto a la clásica llave con actuador:                      Coste inferior - Dimensiones reducidas un 50% - Accionamiento 15 veces más - En aplicaciones de simple efecto, la aplicación es segura y garantizada con una menor fuerza.</i></p> <p>Aplicaciones:                      Instalaciones de aire comprimido e instrumentación. Automatización neumática y de fluidos, Life &amp; sciences. Automoción. Circuitos de agua industrial.</p>		<p><i>Perda de fluxo reduzida graças à característica de passagem plena.                      Funcionamento independente da pressão do circuito principal.                      Compatibilidade com numerosos fluidos, pressões e temperaturas.                      Não existem movimentos externos à válvula.                      Instalação simples e veloz, válvula com atuador já incorporado.                      Possibilidade de modificação do funcionamento de NC para NO e para dupla ação.</i></p> <p><i>Respeito ao classico conceito de válvula com atuador:                      Custo inferior - Dimensões reduzidas em 50% - Acionamentos 15 vezes maior - Nas aplicações de simples ação a posição é segura e garantida com menor força solicitada.</i></p> <p>Aplicações:                      Instalações de ar comprimido e instrumentação, Automação pneumática e fluidica, Life &amp; sciences, Automotiva, Circuitos de água industrial.</p>	



**Perdita di carico e coefficiente nominale**

*Pressure drop and nominal coefficient*

*Druckabfall und nominale Koeffizient*

*Chute de pression et de coefficient nominal*

*Caída de presión y coeficiente nominal*

*Queda de pressão e coeficiente nominal*

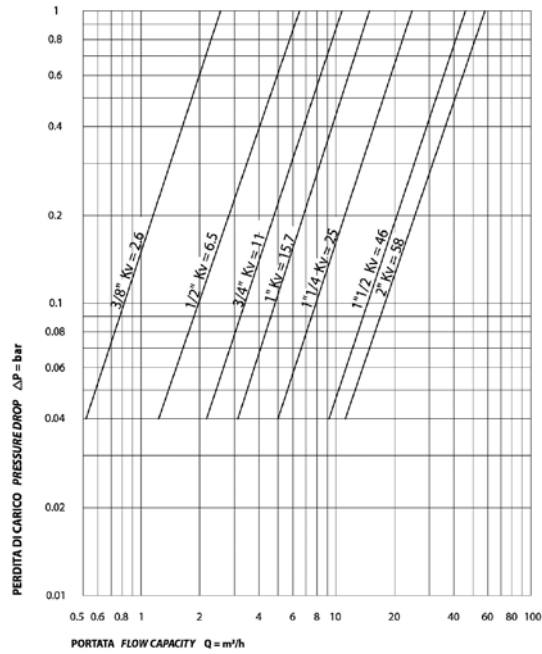

**Diagramma Pressione/temperatura**

*Pressure/temperature chart*

*Druck/Temperatur Diagramm*

*Diagramme pression/température*

*Tabla de presión/temperatura*

*Tabela de pressão/temperatura*

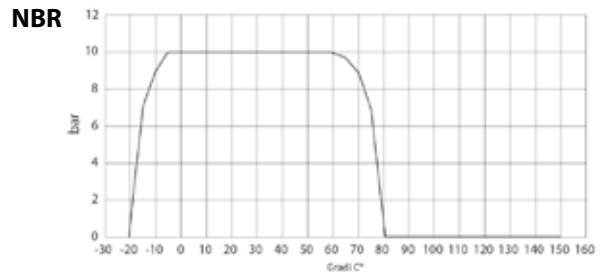
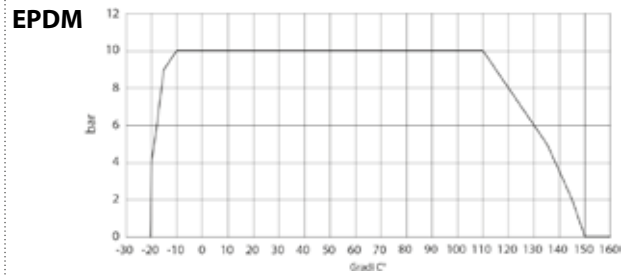
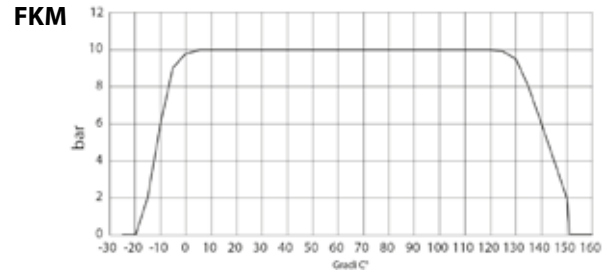

**Tabella dei codici di ordinazione**

*Ordering codes*

*Bestellschlüssel*

*Code de commande*

*Tabla de codificación para pedidos*

*Tabela de codificação para compra*

SERIE	GUARNIZIONE	SIZE MM
-------	-------------	------------

**0 6 0 5 4**

**V**

**0 0**

**0 4**

**06054** Singolo effetto NC  
*Single acting NC*  
*Einfachwirkend NC*  
*Simple effet NC*  
*Simple efecto NC*  
*Simple ação NC*

**V** FKM

**04** 3/8  
**06** 3/4  
**07** 1"  
**09** 1" 1/2  
**10** 2"

**A RICHIESTA - UPON REQUEST - AUF ANFRAGE - SUR DEMANDE - BAJO DEMANDA - SOB ENCOMENDA**

**06055** Singolo effetto NO  
*Single acting NO*  
*Einfachwirkend NO*  
*Simple effet NO*  
*Simple efecto NO*  
*Simple ação NO*

**E** EPDM  
**O** NBR

**06056** Doppio effetto  
*Double acting*  
*Doppeltwirkend*  
*Double effet*  
*Double efecto*  
*Dupla ação*



**Schemi di funzionamento**

*Working plan*

*Arbeitsplan*

*Plan de travail*

*Plan de trabajo*

*Plano de trabalho*

**6054 - NC**

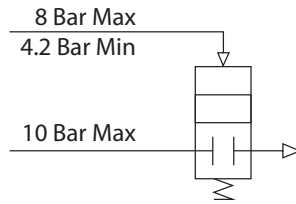

**6055 - NO**

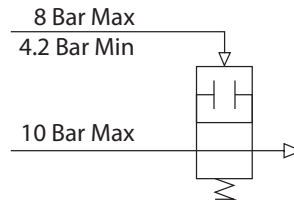

**6056 - Double Acting**

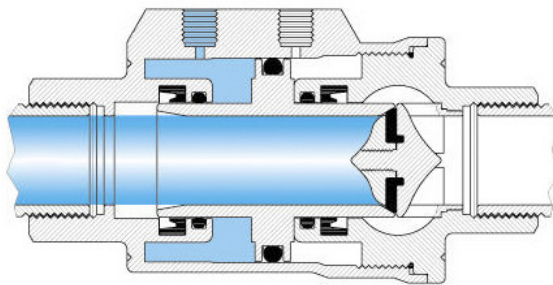
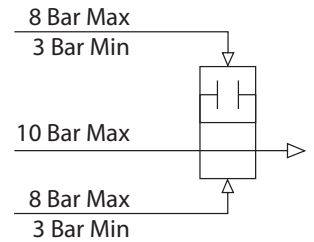

**CLOSED**

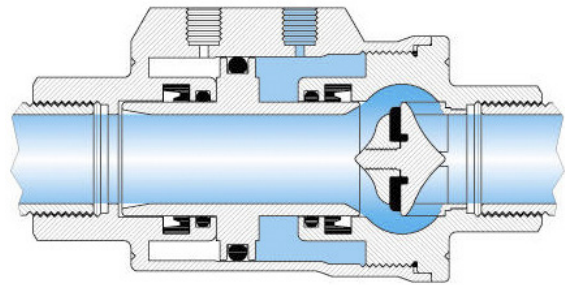

**OPEN**

**6054V**

**VALVOLA COASSIALE DI INTERCETTAZIONE - NC - FKM**

*COAXIAL VALVE - NC - FKM*

*PNEUMATISCHES AXIALVENTIL - NC - FKM*

*VANNE D'ARRÊT - NC - FKM*

*VÁLVULA DE CIERRE - NC - FKM*

*VÁLVULA DE INTERCEPTAÇÃO - NC - FKM*

Code	A	DN	B	L	ØC	D	CH	Pack.
06054 V0 004	3/8	10	54	98	46	31	22	2
06054 V0 006	3/4	20	70	135	63,5	39	33	1
06054 V0 007	1"	25	76	143	69	42	41	1
06054 V0 009	1" 1/2	40	102	180	89	54	60	1
06054 V0 010	2"	50	115	207	109	60	75	1

\* Fino ad esaurimento scorte

\* Until the end stock

\* Nur solange vorrat

\* Livrable jusqu'à épuisement du stock

\* Hasta fin de stock

\* Ate fim do stock

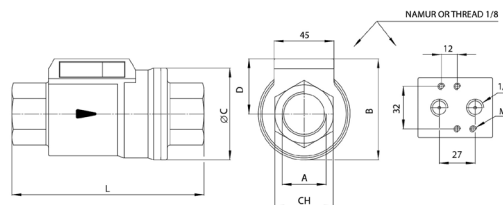

COMANDI UTILIZZABILI - COMMANDS AVAILABLE - VERFÜGBARE BEFEHLE - COMMANDES UTILISABLES - COMANDOS UTILIZABLES - COMANDOS DISPONÍVEIS

**Valvola Elettropneumatica Namur**

*Namur Solenoid Pilot Valve*

*Namur Elektropneumatische Ventile*

*Distributeurs Électropneumatiques Namur*

*Válvulas de Accionamiento Electroneumático Namur*

*Válvulas de Acionamento Eletropneumático Namur*



**Vedi capitolo valvole**

*See chapter valves*

*Siehe Kapitel Ventile*

*Voir chapitre vannes*

*Véase el capítulo Válvulas*

*Consulte o capítulo válvulas*

**Valvola pneumatica Namur**

*Namur Pnumatic Valve*

*Namur Pneumatische Ventile*

*Distributeurs Pneumatiques Namur*

*Válvulas de Accionamiento Neumático Namur*

*Válvulas de Acionamento Pneumático Namur*



**Vedi capitolo valvole**

*See chapter valves*

*Siehe Kapitel Ventile*

*Voir chapitre vannes*

*Véase el capítulo Válvulas*

*Consulte o capítulo válvulas*

**Micro Valvole**

*Micro Valves*

*Mikroventile*

*Microdistributeurs*

*Microválvulas*

*Micro-Válvulas*



**Vedi capitolo valvole**

*See chapter valves*

*Siehe Kapitel Ventile*

*Voir chapitre vannes*

*Véase el capítulo Válvulas*

*Consulte o capítulo válvulas*

