

SERIE 190 MULTISOCKET



Un'unica presa per 4 tipi di innesti

IT

E' un dato di fatto che sul mercato esistono vari profili di innesti ben distinti sia nella forma che nelle dimensioni e generalmente necessitano di essere assemblati con specifiche prese che di norma non sono intercambiabili fra di loro.

Per poter ovviare a questa incompatibilità AIGNEP propone alla sua clientela una soluzione pratica ed economica, un'unica presa da utilizzare con 4 differenti tipi di profili garantendo per tutti una perfetta tenuta.

One socket for 4 different plugs

GB

It is a matter of fact that on the market are available various types of plugs well distinguished whether on the shape or on the dimensions, usually they need to be assembled with specific sockets which normally are not interchangeable.

To get round to this incompatibility AIGNEP is proud to offer to its customers a practical and cost-effective solution, a unique socket to be used with 4 different types of plugs, ensuring a perfect tightening.

1 Kupplung Für 4 Typen Von Steckern

DE

Es ist eine Tatsache, dass die auf dem Markt verfügbaren Kupplungen und Stecker mit verschiedenen, nicht kompatiblen Profilen in Form und Grösse geliefert werden, d.h. sie können nicht untereinander ausgetauscht montiert werden.

Um diese Austauschbarkeit zu ermöglichen, bietet AIGNEP seinen Kunden eine praktische und kostengünstige Lösung an, wo mit einer Kupplung 4 verschiedene Profile (Stecker) verwendet werden können und dennoch eine perfekte Abdichtung gewährleistet ist.

1 Corps pour 4 Embouts

FR

Le marché met à disposition des utilisateurs des différents types de coupleurs qui varient selon les normes, la forme et les dimensions. Souvent il est nécessaire d'assembler plusieurs types de coupleurs qui ne sont pas interchangeables.

Pour contourner cette incompatibilité AIGNEP est fière d'offrir à ses clients une solution pratique, fiable et rentable où un corps unique pour être utilisé avec 4 embouts différents.

Un único enchufe para 4 tipos de adaptador

ES

Es un dato a remarcar que en el mercado existen varios tipos de adaptadores distintos, ya sea en la forma como en las dimensiones, que generalmente necesitan de enchufes específicos no intercambiables entre ellos.

Para solucionar este problema AIGNEP, propone una solución práctica y económica de intercambiabilidad con todos los adaptadores homologados en el mercado europeo, garantizando para todos una perfecta estanqueidad.

Um único soquete p/ 4 tipos de plugs

PT

É um fato que no mercado existem vários perfis de plug bem diferentes entre si, seja no seu formato ou com relação às suas medidas e que, por isto normalmente não são intercambiáveis, necessitando de um soquete específico para cada diferente tipo de plug.

Para fugir desta incompatibilidade de tipos de modelos a AIGNEP propõe a seus clientes uma solução prática e econômica: um único soquete para ser utilizado com 4 diferentes tipos de perfis, garantindo para todos uma vedação perfeita.

PROFIL SWISS
SERIE 270

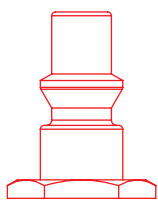

1:1

DN
5.5 mm

Pag. 15.49

PROFIL EUROPEAN
SERIE 260

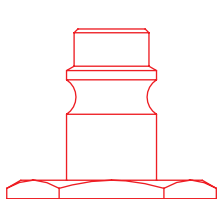

1:1

DN
7.5 - 7.8 mm

Pag. 15.44

PROFIL ITALIAN
SERIE 250

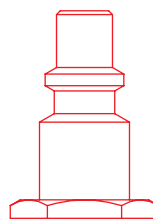

1:1

DN
5 mm

Pag. 15.27

PROFIL UNI ISO 6150 B-12
SERIE 220

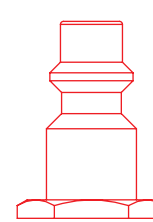

1:1

DN
5.5 mm

Pag. 15.21



CARATTERISTICHE TECNICHE
 TECHNICAL CHARACTERISTICS
 TECHNISCHE ANGABEN
 CARACTÉRISTIQUES TECHNIQUES
 CARACTERÍSTICAS TÉCNICAS
 CARACTERÍSTICAS TÉCNICAS



Norma di Riferimento
 Reference standard
 Entspricht der Norm
 Norme de référence
 Normativa de referencia
 Norma de referència

1907/2006
REACH ✓

2011/65/CE
RoHS ✓

PED
 2014/68/UE

SILICON FREE

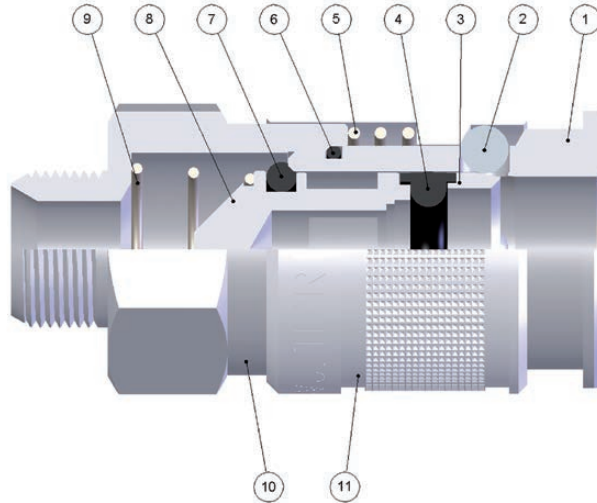

FKM A RICHIESTA
 IF REQUESTED FKM
 FKM AUF ANFRAGE
 FKM SUR DEMANDE
 FKM BAJO DEMANDA
 FKM SOB ENCOMENDA

Materiali e Componenti	IT	Component Parts and Materials	GB	Komponenten und Materialien	DE
1 Corpo in Ottone Nichelato		1 Nickel-Plated Brass Body		1 Körper Messing Vernickelt	
2 Sfera in Acciaio AISI 420		2 Stainless Steel AISI 420 Balls		2 Kugel Edelstahl AISI 420	
3 Anello Guida Innesto in Ottone Nichelato		3 Nickel-Plated Brass Guide Ring Coupling		3 Ring Aus Messing	
4 Guarnizione O-Ring in NBR		4 NBR O-Ring Seals		4 O-Ring NBR	
5 Molla Ghiera in Acciaio AISI 302		5 Stainless Steel AISI 302 Ring Nut Spring		5 Entriegelungsfeder Edelstahl AISI 302	
6 Guarnizione O-Ring in NBR		6 NBR O-Ring Seals		6 O-Ring NBR	
7 Guarnizione O-Ring in NBR		7 NBR O-Ring Seals		7 O-Ring NBR	
8 Otturatore in Ottone Nichelato		8 Nickel-Plated Brass Shutter		8 Verschluss Messing Vernickelt	
9 Molla Otturatore in Acciaio AISI 302		9 Stainless Steel AISI 302 Shutter Spring		9 Verschlussfeder Edelstahl AISI 302	
10 Attacco Terminale in Ottone Nichelato		10 Nickel-Plated Brass Coupling Back Part		10 Einschraubkörper Messing Vernickelt	
11 Ghiera in Ottone Nichelato		11 Nickel-Plated Brass Sleeve		11 Entriegelungshülse Messing Vernickelt	

Matériaux et Composants	FR	Materialies y Componentes	ES	Materialis e Componentes	PT
1 Corps: Laiton Nickelé		1 Cuerpo en latón niquelado		1 Corpo em latão niquelado	
2 Bille: Acier Inoxydable AISI 420		2 Esfera en acero AISI 420		2 Esfera em aço AISI 420	
3 Bague en Laiton		3 Anillo guía enchufe en latón niquelado		3 Anel guia do plug em latão niquelado	
4 Joint Torique en NBR		4 Junta tórica en NBR		4 Vedação O-Ring em NBR	
5 Ressort de Bague: Acier Inoxydable AISI 302		5 Muelle tuerca en acero AISI 302		5 Mola de porca em aço AISI 302	
6 Joint Torique en NBR		6 Junta tórica en NBR		6 Vedação O-Ring em NBR	
7 Joint Torique en NBR		7 Junta tórica en NBR		7 Vedação O-Ring em NBR	
8 Clapet en Laiton Nickelé		8 Obturador en latón niquelado		8 Obturador em latão niquelado	
9 Ressort de Clapet: Acier Inoxydable AISI 302		9 Muelle obturador en acero AISI 302		9 Mola do obturador em aço AISI 302	
10 Corps: Laiton Nickelé		10 Conexión terminal en latón niquelado		10 Conexão terminal em latão niquelado	
11 Bague: Laiton Nickelé		11 Tuerca en latón niquelado		11 Porca em latão niquelado	



Temperature
 Temperatures
 Temperatur
 Températures
 Temperaturas
 Temperaturas

- 20 °C
+ 80 °C

Con O-ring in FKM
 With FKM O-ring
 Mit O-ring in FKM
 Avec Joints en FKM
 Con Junta tórica en FKM
 Com O-ring em FKM

- 10 °C
+ 200 °C



Fluidi compatibili
 Aria compressa
 Fluids
 Compressed air
 Geeignete Medien
 Druckluft

Fluides compatibles
 Air comprimé

Fluidos compatibles
 Aire comprimido

Fluidos compatíveis
 Ar comprimido

Per altri fluidi, consultare l'ufficio tecnico Aignep.
 For other fluids, consult the technical department Aignep.
 Für andere Flüssigkeiten, kontaktieren Sie uns.
 Pour d'autres fluides, veuillez nous consulter.
 Para otros fluidos póngase en contacto con el departamento técnico Aignep.
 Para outros fluidos consulte o departamento técnico da Aignep.



Pressione d'esercizio

Working Pressures

Betriebsdruck

Pression de service

Presión de Ejercicio

Pressão de Trabalho

0 bar
16 bar



Max pressione statica (no pulsazioni)

Maximum static pressure (no pulsations)

Maximaler statischer Betriebsdruck (ohne pulsations)

Pression statique maximale (sans pulsation)

Presión estática máxima (sin pulsaciones)

Pressão estática máxima (sem pulsações)

35 bar



Portata

NI/min

Flow Rate

Durchflusswerte

Débit

Caudal de Flujo

Vazão

Innesto Plug Stecker Embout Adaptador Plug	6 bar Δ 1	6 bar Δ 0.5	6 bar *
220	900	700	1450
250	800	700	1300
260 (7.5)	1350	1000	2150
260 (7.8)	1510	1200	2250
270	1100	750	1600

* Scarico libero - Exhaust Free - Freier Auslass - Échappement libre - Escape Libre - Descarga livre.



Filettatura

IT

Threads

GB

Gewindearten

DE

Gas cilindrica conforme ISO 228 Classe A.

Parallel gas in conformity with ISO 228 Class A.

Zylindrisches Gewinde nach Norm ISO 228 Classe A.

Filetages

FR

Roscas

ES

Roscas

PT

Filetage cylindrique conforme: ISO 228 Classe A.

Gas cilindrica conforme ISO 228 Classe A.

Gas paralela conforme ISO 228 Classe A.

191

PRESA MASCHIO

MALE SOCKET

VERSCHLUSS-KUPPLUNG MIT AUSSENGEWINDE

COUPLEUR MÂLE

ENCHUFE MACHO

SOQUETE COM ROSCA MACHO

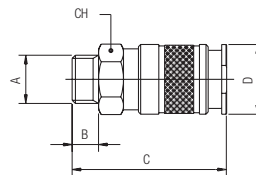

Code	A	B	C	D	CH	Pack.
00191 00 001	1/4	8	49	24	21	10
00191 00 002	3/8	9	50	24	21	10
00191 00 003	1/2	10	51	24	24	10
Code FKM						
00191 V0 001	1/4	8	49	24	21	10
00191 V0 002	3/8	9	50	24	21	10
00191 V0 003	1/2	10	51	24	24	10

192

PRESA FEMMINA

FEMALE SOCKET

VERSCHLUSS-KUPPLUNG MIT INNENGEWINDE

COUPLEUR FEMELLE

ENCHUFE HEMBRA

SOQUETE COM ROSCA FÊMEA

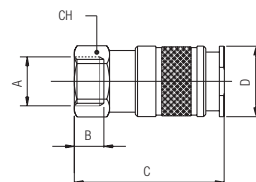

Code	A	B	C	D	CH	Pack.
00192 00 001	1/4	11	51	24	21	10
00192 00 002	3/8	11.5	51	24	21	10
00192 00 003	1/2	14	55	24	24	10
Code FKM						
00192 V0 001	1/4	11	51	24	21	10
00192 V0 002	3/8	11.5	51	24	21	10
00192 V0 003	1/2	14	55	24	24	10

193

PRESA A CALZAMENTO CON MOLLA

COMPRESSION SOCKET WITH SPRING
 VERSCHLUSS-KUPPLUNG MIT KNICKSCHUTZFEDER
 COUPLEUR AVEC RESSORT DE PROTECTION
 ENCHUFE TUBO CON MUELLE
 SOQUETE COM CONEXÃO PUSH-ON COM MOLA

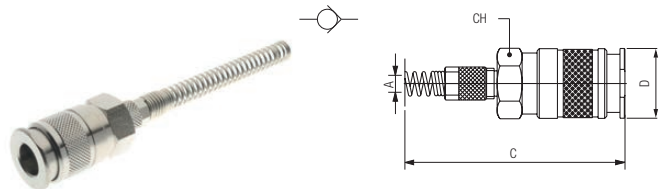

Code	A	C	D	CH	Pack.
00193 00 001	6/4	138	24	21	10
00193 00 002	8/6	144.5	24	21	10
00193 00 004	10/6.5	153.5	24	21	10
00193 00 003	10/8	153.5	24	21	10
00193 00 006	12/8-12/9	159	24	21	10
00193 00 005	12/10	159	24	21	10

Molla Acciaio Inox AISI 304 - EN 1.4301
 Stainless Steel Spring AISI 304 - EN 1.4301
 Edelstahlfeder AISI 304 - EN 1.4301
 Ressort Acier Inoxydable AISI 304 - EN 1.4301
 Muelle Acero Inoxidable AISI 304 - EN 1.4301
 Mola Aço Inoxidável AISI 304 - EN 1.4301

194

PRESA A CALZAMENTO

COMPRESSION SOCKET
 VERSCHLUSS-KUPPLUNG MIT ÜBERWURFVERSCHRAUBUNG
 COUPLEUR RACCORD À COIFFE
 ENCHUFE TUBO
 SOQUETE COM CONEXÃO PUSH-ON

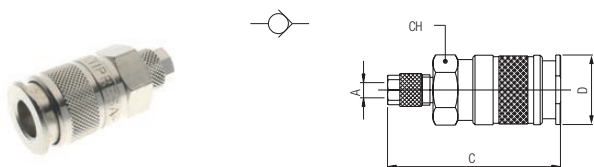

Code	A	C	D	CH	Pack.
00194 00 001	6/4	55	24	21	10
00194 00 002	8/6	55	24	21	10
00194 00 003	10/8	55	24	21	10
00194 00 007	12/10	57.5	24	21	10

195

PRESA CON PORTAGOMMA A RESCA

BARBED SOCKET
 VERSCHLUSS-KUPPLUNG MIT SCHLAUCHTÜLLE
 COUPLEUR À DOUILLE ANNELÉE POUR TUBE
 ENCHUFE ESPIGA
 SOQUETE COM ESPIGÃO PARA MANGUEIRA DE BORRACHA

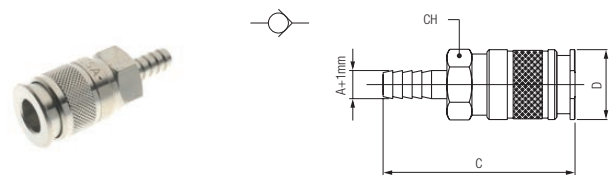

Code	A	C	D	CH	Pack.
00195 00 001	6	61	24	21	10
00195 00 002	8	61	24	21	10
00195 00 003	10	61	24	21	10
00195 00 004	12	61	24	21	10

196

PRESA CON PORTAGOMMA

SOCKET FOR RUBBER HOSE
 VERSCHLUSS-KUPPLUNG FÜR GUMMISCHLAUCH
 COUPLEUR À DOUILLE ANNELÉE POUR TUBE
 ENCHUFE CON PORTAGOMA
 SOQUETE COM ESPIGÃO PARA TUBO DE BORRACHA

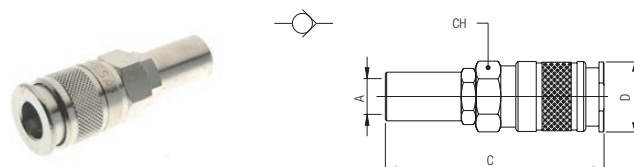

Code	A	C	D	CH	Pack.
00196 00 001	14/6	71	24	21	10
00196 00 002	17/8	71	24	21	10
00196 00 003	19/10	71	24	21	10