

VALVOLE ELETTROPNEUMATICHE - G1/8

ELECTRO PNEUMATIC VALVE ISLANDS - G1/8

ELEKTROPNEUMATISCHE VENTILINSELN - G1/8

ILOT DE DISTRIBUTION PNEUMATIQUE - G1/8

ISLAS DE VALVULAS ELECTRONEUMATICAS - G1/8

TERMINAL DE VÁLVULAS ELETROPNEUMÁTICAS - G1/8

New

Serie 14V

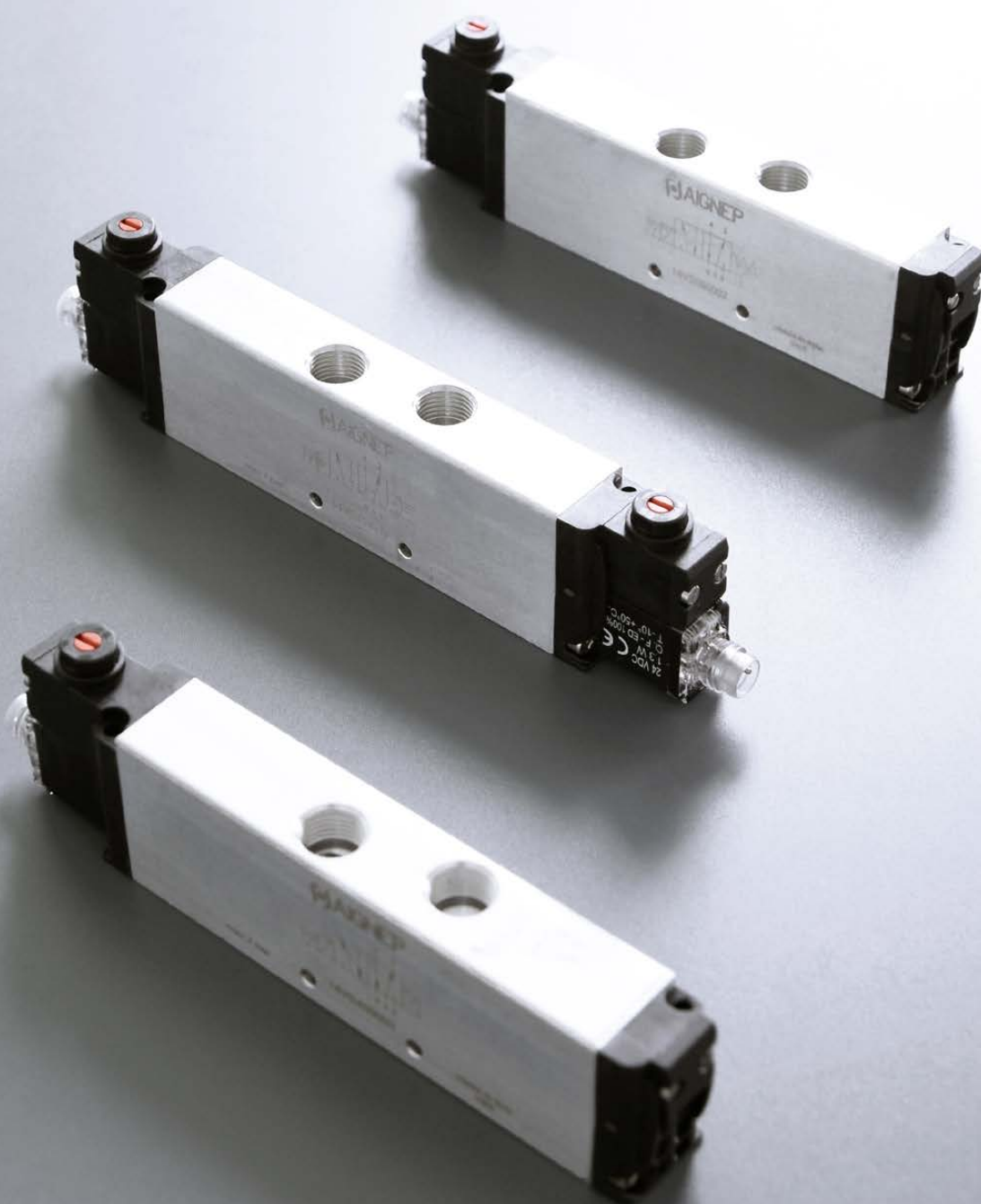

New

VALVOLE ELETTROPNEUMATICHE - G1/8

ELECTRO PNEUMATIC VALVE ISLANDS - G1/8
 ELEKTROPNEUMATISCHE VENTILINSEL - G1/8
 ILOT DE DISTRIBUTION PNEUMATIQUE - G1/8
 ISLAS DE VALVULAS ELECTRONEUMATICAS - G1/8
 TERMINAL DE VÁLVULAS ELETROPNEUMÁTICAS - G1/8



CARATTERISTICHE TECNICHE
 TECHNICAL CHARACTERISTICS
 TECHNISCHE ANGABEN
 CARACTÉRISTIQUES TECHNIQUES
 CARACTERÍSTICAS TÉCNICAS
 CARACTERÍSTICAS TÉCNICAS

16 mm

**Flow rate:
 553 → 706 NI/min**



1907/2006
REACH ✓

2011/65/CE
RoHS ✓

PED
 2014/68/UE



Materiali e Componenti

IT

- Corpo: alluminio anodizzato
- Spola: alluminio nichelato
- Guarnizioni spola e pistoni: elastomero
- Molle: acciaio inox AISI 302

Component Parts and Materials

GB

- Body: anodised aluminium
- Spule in nickel-plated aluminium
- Piston & Spool Seals in Elastomer
- Springs: Stainless steel AISI 302

Komponenten und Materialien

DE

- Gehäuse: Eloxiertes Aluminium
- Spule: Vernickeltes Aluminium
- Spulen- und Kolben-Dichtungen: Elastomere
- Federn: Rostfreier Stahl AISI 302

Matériaux et Composants

FR

- Corps: Aluminium anodisé
- Tiroir: aluminium nickelé
- Joints tiroir et piston: elastomère
- Ressort: Acier inoxydable AISI 302

Materiales y Componentes

ES

- Cuerpo: aluminio anodizado
- Corredera: aluminio niquelado
- Juntas corredera y pistón: elastómero
- Muelle: acero Inox AISI 302

Materiais e Componentes

PT

- Corpo: alumínio anodizado
- Carretel: alumínio niquelado
- Vedação do carretel e êmbolo: elastômero
- Mola: aço inox AISI 302



Connessioni di utilizzo filettate

IT

- Sistema di connessione elettrica integrato di serie
- Grado di protezione IP65
- Taglia unica 16 mm di spessore
- Connessioni di utilizzo con filettatura femmina ricavate nel corpo valvola
- Composizione rapida, veloce e con pochi elementi del gruppo elettrovalvole

Threaded connections

GB

- Integrated electrical connection system
- IP65 protection
- 16 mm thickness
- Usage connections with female threads machined in the valve body
- Quick, fast and with few elements of the solenoid valve roup

Gewindeanschlüsse

DE

- Integriertes elektrisches Anschlussystem
- Schutzklasse IP65
- 16 mm Breite
- Verwendung von Anschlüssen mit Innengewinden, die in das Ventilgehäuse eingearbeitet sind
- Schnelle Montage der Magnetventile

Connexions filetéés

FR

- Système de connexion électrique intégré
- Indice de protection IP65
- 16 mm d'épaisseur
- Raccords d'utilisation avec filetage femelle usiné dans le corps de la vanne
- Rapide, avec peu d'éléments d'électrovannes

Conexiones roscadas

ES

- Sistema de conexión eléctrica integrada de serie
- Grado de protección IP65
- Talla única 16 mm de espesor
- Conexiones de uso con roscas hembra mecanizadas en el cuerpo de la válvula
- Montaje rápido y con pocos elementos en el grupo de electroválvulas

Conexões roscadas

PT

- Sistema de conexões elétricas integradas de série
- Grau de proteção IP65
- Tamanho único 16 mm de espessura
- Conexões de uso com roscas fêmeas usinadas no corpo da válvula
- Composição rápida e com poucos elementos

	TIPO DI ELETTROVALVOLA TYPE OF SOLENOID VALVE MAGNETVENTIL-TYP TYPE DE DISTRIBUTEUR TIPO DE ELECTROVÁLVULA TIPO DE ELETRO-VÁLVULA				Tenuta in elastomero Elastomer sealing Elastomer-dichtung Etancheité elastomère Estanqueidad en elastómero Vedação por elastômero		
	ATTACCO FILETTATO THREADED ANSCHLUSS CONNEXION ROSCA CONEXÃO ROSCADA				G 1/8 - ISO 228		
	FLUIDI FLUIDS MEDIEN FLUIDES FLUIDOS FLUIDOS				Aria Air Air Air Aire Ar		
	Monostabile con ritorno a molla pneumatica - Monostable pneumatic spring return - Monostabil mit pneumatischer feder Monostable à rappel mécanique par ressort - Monoestable con retorno por muelle neumático - Monoestável com retorno por mola pneumática				1.5 ÷ 7 bar		
	Monostabile con ritorno a molla meccanica - Monostable mechanical spring return - Monostabil mit federrückstellung Monostable à rappel mécanique par ressort - Monoestable con retorno por muelle mecánico - Monoestável com retorno por mola mecânica				3 ÷ 7 bar		
	PRESSIONE DI ESERCIZIO OPERATING PRESSURE BETRIEBSDRUCK PRESSION DE SERVICE PRESIÓN DE EJERCICIO PRESSÃO DE OPERAÇÃO						
	Bistabile a 2 posizioni - 2-way valve bistable - Bistabil 2-Weg Bistable à 2 positions - Biestable a 2 posiciones - Biestável de 2 posições				1 ÷ 7 bar		
	3 posizioni - 3-way valve - 3-Weg 3 positions - 3 posiciones - 3 posições				2 ÷ 7 bar		
	Elettrovalvola 5/4 (doppia 3/2) - 5/4-way valve double (3/2) - Magnetventil 5/4-Doppelkorpus (3/2) Distributeur 5/4 double (3/2) - Electroválvula 5/4 doble (3/2) - Eletro-válvula 5/4 com 2 válvulas (3/2)				1.5 ÷ 7 bar		
	TEMPERATURA DI ESERCIZIO OPERATING TEMPERATURE BETRIEBSTEMPERATUR TEMPÉRATURE DE SERVICE TEMPERATURA TEMPERATURA				-5 ÷ 50 °C Senza congelamento Without freezing Ohne Vereisung Hors gel Sin congelación Sem congelamento		
	COMANDO MANUALE MANUAL CONTROL MANUELLE BETÄTIGUNG COMMANDE MANUELLE COMANDO MANUAL ACIONAMIENTO MANUAL				A rotazione con blocco Rotating with lock Drehen mit Schloss Tournant avec verrou Rotación con bloqueo Rotativo com trava		
	TIPO CON SCARICO PILOTA WITH PILOT EXHAUST TYP MIT PILOT-AUSLASS TYPE D'ÉCHAPPEMENT PILOTE TIPO CON ESCAPE PILOTO COM ESCAPE DE PILOTO				Scarico individuale in atmosfera Individual discharge to atmosphere Individuelle Ableitung in die Atmosphäre Rejet individuel dans l'atmosphère Descarga individual a la atmósfera Descarga individual para a atmosfera		
	FILTRAZIONE CONSIGLIATA SUGGESTED FILTRATION EMPFOHLENE FILTRATION FILTRATION RECOMMANDÉE FILTRACIÓN RECOMENDADA FILTRAGEM RECOMENDADA	≤ 20 µm		LUBRIFICAZIONE LUBRICATION SCHMIERUNG LUBRIFICATION LUBRIFICACIÓN LUBRIFICAÇÃO	Non necessaria Not necessary Nicht erforderlich Pas nécessaire No necesaria Não necessária		
	TIPO DI INTERFACCIA TYPE OF INTERFACE ART DER SCHNITTSTELLE TYPE D'INTERFACE TIPO DE INTERFAZ TIPO DE INTERFACE				Connettore maschio M8		
	GRADO DI PROTEZIONE PROTECTION DEGREE SCHUTZGRAD CLASSE DE PROTECTION GRADO DE PROTECCIÓN GRAU DE PROTEÇÃO				IP65 con connettore collegato IP65 with connector attached IP65 mit angeschlossenem Stecker IP65 avec connecteur attaché IP65 con connector incorporado IP65 com conector acoplado		
	TENSIONE DI ALIMENTAZIONE VOLTAGE VERSORGUNGSSPANNUNG TENSION D'ALIMENTATION TENSIÓN DE ALIMENTACIÓN TENÇÃO DE ALIMENTAÇÃO	24 VDC		ASSORBIMENTO ELETTROPILOTI POWER CONSUMPTION STROMAUFNAHME ELEKTROPILOTEN ABSORPTION BOBINES CONSUMO ELECTROPILOTOS CONSUMO DE ENERGIA	1.3 W		
	FLUTTUAZIONE DI TENSIONE AMMISSIBILE (V) ALLOWABLE VOLTAGE FLUCTUATIONS (V) ZULÄSSIGE SPANNUNGSSCHWANKUNG (V) FLUCTUATION DE TENSION ADMISSE (V) FLUCTUACIÓN DE TENSIÓN ADMISIBLE (V) FLUTUAÇÃO ADMISSÍVEL DA TENÇÃO (V)	±10% della tensione nominale ±10% of nominal voltage ±10% der Nennspannung ±10% de la tension nominale ±10% de la tensión nominal ±10% da tensão nominal		FREQUENZA MASSIMA DI COMMUTAZIONE MAX SWITCHING FREQUENCY MAXIMALE SCHALTFREQUENZ FREQUENCE DE COMMUTATION MAXIMALE FRECUENCIA MÁXIMA DE CONMUTACIÓN FREQUÊNCIA MÁXIMA DE COMUTAÇÃO	3 Hz		
	SEGNALE VISIVO DELLA ELETTROVALVOLA PILOTA VISUAL SIGNAL OF PILOT VALVE SICHTANZEIGE DES PILOTVENTILS SIGNAL VISUEL DU DISTRIBUTEUR PILOTE SEÑAL VISUAL DE LA ELECTROVÁLVULA PILOTO TIPO DE SINAL VISÍVEL DO PILOTO				LED		
	TEMPI DI COMMUTAZIONE SWITCHING TIMES SCHALTZEITEN TEMPS DE COMMUTATION TIEMPOS DE CONMUTACIÓN TEMPOS DE COMUTAÇÃO						
			5/4	5/2 Pneumatic return	5/2 Spring return	5/2 Bistable	5/3 Monostable
	Switching time on (ms) OUT (2)	11	21	17	14	17	
	Switching time on (ms) OUT (4)	19	-	-	19	31	
	Switching time off (ms) OUT (2)	26	-	-	-	-	
	Switching time off (ms) OUT (4)	41	44	56	-	-	

ELETTROVALVOLE - G1/8

SOLENOID VALVES - G1/8
 MAGNETVENTILE - G1/8
 DISTRIBUTEURS - G1/8
 ELECTROVALVULAS - G1/8
 ELETROVÁLVULAS - G1/8

5/2 Vie - Ways - Wege - Voies - Vías - Vias

New

MONOSTABILE CON RITORNO PNEUMATICO

MONOSTABLE WITH PNEUMATIC SPRING RETURN
 MONOSTABIL MIT PNEUMATISCHER FEDER
 MONOSTABLE À RAPPEL MECANIQUE PAR RESSORT
 MONOESTABLE CON RETORNO POR MUELLE NEUMÁTICO
 MONOESTÁVEL COM RETORNO POR MOLA PNEUMÁTICA



Codice	Vie	Portata	Misura
Code	Ways	Flow rate	Size
Nummer	Wege	Durchflusswert	Größe
Code	Voies	Débit	Dimension
Código	Vías	Caudal	Medida
Código	Vias	Vazão	Tamanho
14V S4 5 00 02	5/2	706 NI/min	1/8

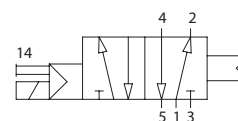

5/2 Vie - Ways - Wege - Voies - Vías - Vias

New

MONOSTABILE CON RITORNO A MOLLA MECCANICA

MONOSTABLE MECHANICAL SPRING RETURN
 MONOSTABIL MIT FEDERRÜCKSTELLUNG
 MONOSTABLE À RAPPEL MECANIQUE PAR RESSORT
 MONOESTABLE CON RETORNO POR MUELLE MECÁNICA
 MONOESTÁVEL COM RETORNO POR MOLA MECÂNICA



* SU RICHIESTA
 * ON REQUEST
 * AUF ANFRAGE
 * ON DEMAND
 * A PETIÇÃO
 * A PEDIDO

Codice	Vie	Portata	Misura
Code	Ways	Flow rate	Size
Nummer	Wege	Durchflusswert	Größe
Code	Voies	Débit	Dimension
Código	Vías	Caudal	Medida
Código	Vias	Vazão	Tamanho
14V S0 5 00 02	5/2	706 NI/min	1/8

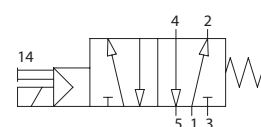

14V S4 5 00 02 14V S0 5 00 02

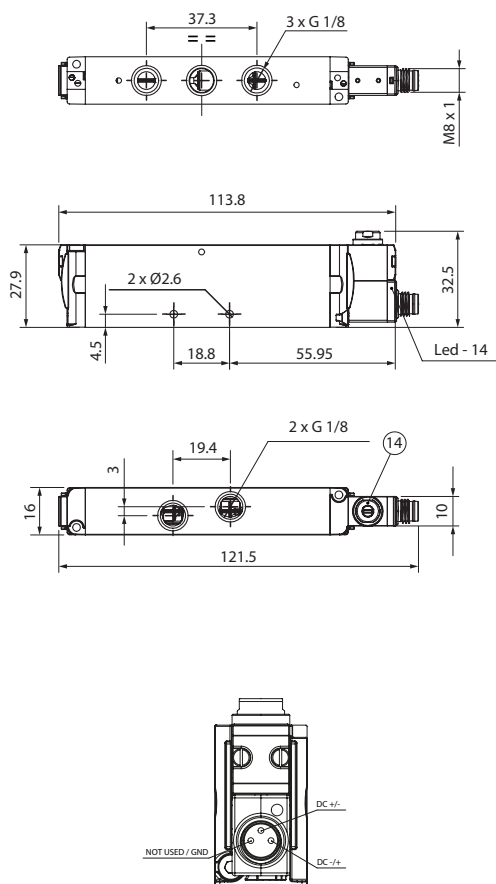

5/2 Vie - Ways - Wege - Voies - Vías - Vias

New

BISTABILE

TWO STABLE POSITIONS

BISTABIL

BISTABLE

BIESTABLE

BIESTÁVEL



Codice Code Nummer Code Código Código	Vie Ways Wege Voies Vías Vias	Portata Flow rate Durchflusswert Débit Caudal Vazão	Misura Size Größe Dimension Medida Tamanho
14V S1 5 00 02	5/2	706 NI/min	1/8

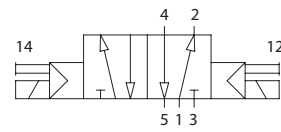

14V S1 5 00 02

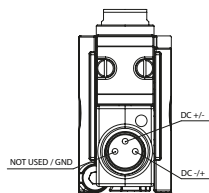
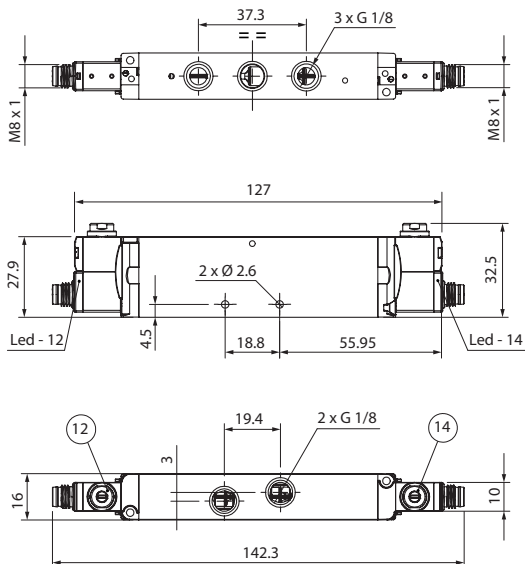

5/3 Vie - Ways - Wege - Voies - Vías - Vias

New

MONOSTABILE CON RITORNO A MOLLA MECCANICA

MONOSTABLE MECHANICAL SPRING RETURN

MONOSTABIL MIT FEDERRÜCKSTELLUNG

MONOSTABLE À RAPPEL MECANIQUE PAR RESSORT

MONOESTABLE CON RETORNO POR MUELLE MECÁNICO

MONOESTÁVEL COM RETORNO POR MOLA MECÂNICA



Codice Code Nummer Code Código Código	Vie Ways Wege Voies Vías Vias	Funzione Function Funktion Fonction Función Funções	Portata Flow rate Durchflusswert Débit Caudal Vazão	Misura Size Größe Dimension Medida Tamanho
14V S0 7 CC 02	5/3	CC	591 NI/min	1/8
14V S0 7 OC 02	5/3	OC	705 NI/min	1/8
14V S0 7 PC 02	5/3	PC	680 NI/min	1/8

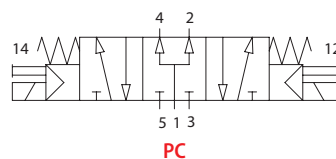
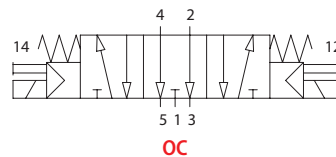
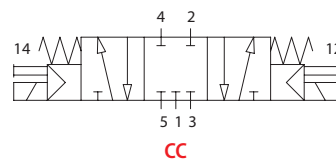

14V S0 7 CC 02 14V S0 7 OC 02 14V S0 7 PC 02

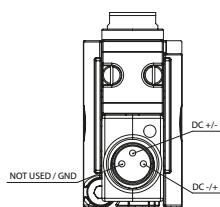
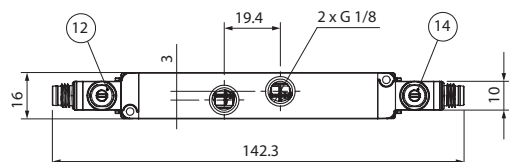
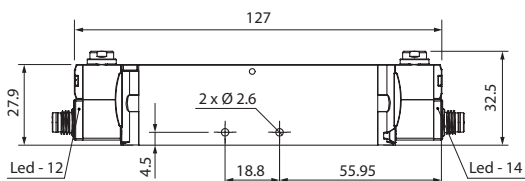
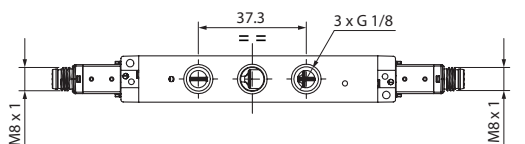

5/4 Vie - Ways - Wege - Voies - Vías - Vias

DOPPIA 3/2 MONOSTABILE CON RITORNO A MOLLA MECCANICA

DOUBLE 3/2 MONOSTABLE MECHANICAL SPRING RETURN

MONOSTABILES 3/2-WEGE-DOPPELVENTIL MIT MECHANISCHER FEDERRÜCKSTELLUNG

DOUBLE 3/2 A RAPPET MECANIQUE PAR RESSORT

DOBLE 3/2 MONOESTABLE CON RETORNO POR MUELLE MECÁNICO

ELETRO-VÁLVULA DUPLA (2 VÁLVULAS 3/2 VIAS) RETORNO MOLA MECÂNICA

New



Codice Code Nummer Code Código Código	Vie Ways Wege Voies Vías Vias	Funzione Function Funktion Fonction Función Funções	Portata Flow rate Durchflusswert Débit Caudal Vazão	Misura Size Größe Dimension Medida Tamanho
14V S0 8 NC 02	5/4	NC	553 NI/min	1/8
14V S0 8 NO 02	5/4	NO	620 NI/min	1/8
14V S0 8 NN 02	5/4	NC-NO	553 NI/min	1/8

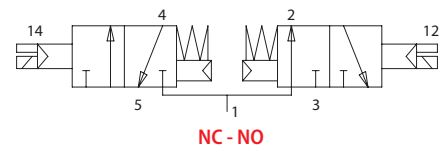
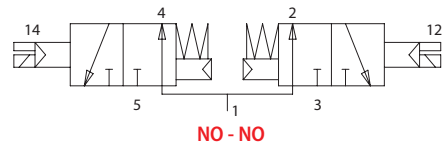
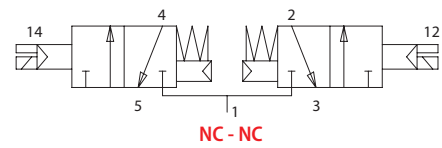

14V S0 8 CC 02 14V S0 8 OC 02 14V S0 8 PC 02

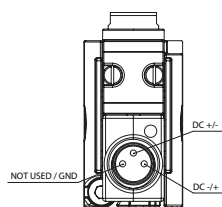
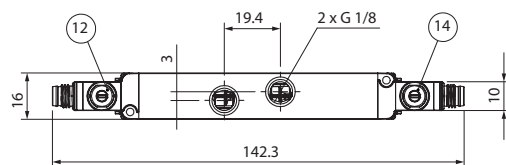
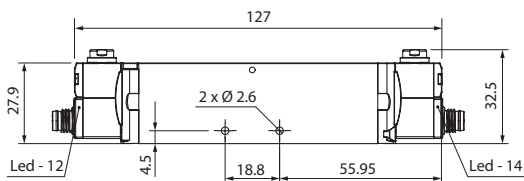
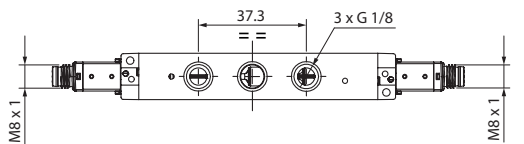

New

VALVOLE AD AZIONAMENTO PNEUMATICO - G1/8

PNEUMATIC VALVE - G1/8
 PNEUMATISCHE VENTILE - G1/8
 DISTRIBUTEURS PNEUMATIQUES - G1/8
 VÁLVULAS DE ACCIONAMIENTO NEUMÁTICO - G1/8
 VÁLVULAS DE ACIONAMENTO PNEUMÁTICO - G1/8



CARATTERISTICHE TECNICHE
 TECHNICAL CHARACTERISTICS
 TECHNISCHE ANGABEN
 CARACTÉRISTIQUES TECHNIQUES
 CARACTERÍSTICAS TÉCNICAS
 CARACTERÍSTICAS TÉCNICAS

16 mm

**Flow rate:
 553 → 706 NI/min**



1907/2006
REACH

2011/65/CE
RoHS

PED
 2014/68/UE



IT	Component Parts and Materials	GB	Komponenten und Materialien	DE
<ul style="list-style-type: none"> Corpo: alluminio anodizzato Spola: alluminio nichelato Guarnizioni spola e pistoni: elastomero Molle: acciaio inox AISI 302 	<ul style="list-style-type: none"> Body: anodised aluminium Spool in nickel-plated aluminium Piston & Spool Seals in Elastomer Springs: Stainless steel AISI 302 		<ul style="list-style-type: none"> Gehäuse: Eloxiertes Aluminium Spule: Vernickeltes Aluminium Spulen- und Kolben-Dichtungen: Elastomere Federn: Rostfreier Stahl AISI 302 	

FR	Materiales y Componentes	ES	Materiais e Componentes	PT
<ul style="list-style-type: none"> Corps: Aluminium anodisé Tiroir: aluminium nickelé Joints tiroir et piston: elastomère Ressort: Acier inoxydable AISI 302 	<ul style="list-style-type: none"> Cuerpo: aluminio anodizado Corredera: aluminio niquelado Juntas corredera y pistón: elastómero Muelle: acero Inox AISI 302 		<ul style="list-style-type: none"> Corpo: alumínio anodizado Carretel: alumínio niquelado Vedação do carretel e êmbolo: elastômero Mola: aço inox AISI 302 	



IT	Threaded connections	GB	Gewindeanschlüsse	DE
<ul style="list-style-type: none"> Grado di protezione IP65 Taglia unica 16 mm di spessore Connessioni di utilizzo con filettatura femmina ricavate nel corpo valvola Composizione rapida, veloce e con pochi elementi del gruppo elettrovalvole 	<ul style="list-style-type: none"> IP65 protection 16 mm thickness Usage connections with female threads machined in the valve body Quick, fast and with few elements of the solenoid valve group 		<ul style="list-style-type: none"> Schutzklasse IP65 16 mm Breite Verwendung von Anschlüssen mit Innengewinden, die in das Ventilgehäuse eingearbeitet sind Schnelle Montage der Magnetventile 	

FR	Conexiones roscadas	ES	Conexões roscadas	PT
<ul style="list-style-type: none"> Indice de protection IP65 16 mm d'épaisseur Raccords d'utilisation avec filetage femelle usiné dans le corps de la vanne Rapide, avec peu d'éléments d'électrovanne 	<ul style="list-style-type: none"> Grado de protección IP65 Talla única 16 mm de espesor Conexiones de uso con roscas hembra mecanizadas en el cuerpo de la válvula Montaje rápido y con pocos elementos en el grupo de electroválvulas 		<ul style="list-style-type: none"> Grau de proteção IP65 Tamanho único 16 mm de espessura Conexões de uso com roscas fêmeas usinadas no corpo da válvula Composição rápida e com poucos elementos 	

	TIPO DI ELETTROVALVOLA TYPE OF SOLENOID VALVE MAGNETVENTIL-TYP TYPE DE DISTRIBUTEUR TIPO DE ELECTROVÁLVULA TIPO DE ELETRO-VÁLVULA	Tenuta in elastomero Elastomer sealing Elastomer-dichtung Etancheité elastomère Estanqueidad en elastómero Vedação por elastômero				
	ATTACCO FILETTATO THREADED ANSCHLUSS CONNEXION ROSCA CONEXÃO ROSCADA	G 1/8 - ISO 228				
	FLUIDI FLUIDS MEDIEN FLUIDES FLUIDOS FLUIDOS	Aria Air Air Air Aire Ar				
Monostabile con ritorno a molla pneumatica - Monostable pneumatic spring return - Monostabil mit pneumatischer Feder Monostable à rappel mécanique par ressort - Monoestable con retorno por muelle neumático - Monoestável com retorno por mola pneumática		1.5 ÷ 7 bar				
Monostabile con ritorno a molla meccanica - Monostable mechanical spring return - Monostabil mit Federrückstellung Monostable à rappel mécanique par ressort - Monoestable con retorno por muelle mecánico - Monoestável com retorno por mola mecânica		3 ÷ 7 bar				
	PRESSIONE DI ESERCIZIO OPERATING PRESSURE BETRIEBSDRUCK PRESSION DE SERVICE PRESIÓN DE EJERCICIO PRESSÃO DE OPERAÇÃO	Bistabile a 2 posizioni - 2-way valve bistable - Bistabil 2-Weg Bistable à 2 positions - Biestable a 2 posiciones - Biestável de 2 posições		1 ÷ 7 bar		
3 posizioni - 3-way valve - 3-Weg - 3 positions - 3 posiciones - 3 posições		2 ÷ 7 bar				
Elettrovalvola 5/4 (doppia 3/2) - 5/4-way valve double (3/2) - Magnetventil 5/4-Doppelkorpus (3/2) Distributeur 5/4 double (3/2) - Electroválvula 5/4 doble (3/2) - Eletro-válvula 5/4 com 2 válvulas (3/2)		1.5 ÷ 7 bar				
	TEMPERATURA DI ESERCIZIO OPERATING TEMPERATURE BETRIEBSTEMPERATUR TEMPÉRATURE DE SERVICE TEMPERATURA TEMPERATURA	-5 ÷ 50 °C			Senza congelamento Without freezing Ohne Vereisung Hors gel Sin congelación Sem congelamento	
	TIPO CON SCARICO PILOTA WITH PILOT EXHAUST TYP MIT PILOT-AUSLASS TYPE D'ÉCHAPPEMENT PILOTE TIPO CON ESCAPE PILOTO COM ESCAPE DE PILOTO	Scarico individuale in atmosfera Individual discharge to atmosphere Individuelle Ableitung in die Atmosphäre Rejet individuel dans l'atmosphère Descarga individual a la atmósfera Descarga individual para a atmosfera				
	FILTRAZIONE CONSIGLIATA SUGGESTED FILTRATION EMPFOHLENE FILTRATION FILTRATION RECOMMANDÉE FILTRACIÓN RECOMENDADA FILTRAGEM RECOMENDADA	≤ 20 µm		LUBRIFICAZIONE LUBRICATION SCHMIERUNG LUBRIFICACION LUBRIFICACIÓN LUBRIFICAÇÃO	Non necessaria Not necessary Nicht erforderlich Pas nécessaire No necesaria Não necessária	
	GRADO DI PROTEZIONE PROTECTION DEGREE SCHUTZGRAD CLASSE DE PROTECTION GRADO DE PROTECCIÓN GRAU DE PROTEÇÃO	IP65 con connettore collegato IP65 with connector attached IP65 mit angeschlossenen Stecker IP65 avec connecteur attaché IP65 con conector incorporado IP65 com conector acoplado				
	TEMPI DI COMMUTAZIONE SWITCHING TIMES SCHALTZEITEN TEMPS DE COMMUTATION TIEMPOS DE CONMUTACIÓN TEMPOS DE COMUTAÇÃO	5/4	5/2 Pneumatic return	5/2 Spring return	5/2 Bistable	5/3 Monostable
Switching time on (ms) OUT (2)		11	21	17	14	17
Switching time on (ms) OUT (4)		19	-	-	19	31
Switching time off (ms) OUT (2)		26	-	-	-	-
Switching time off (ms) OUT (4)		41	44	56	-	-

VALVOLE AD AZIONAMENTO PNEUMATICO - G1/8

PNEUMATIC VALVE - G1/8
 PNEUMATISCHE VENTILE - G1/8
 DISTRIBUTEURS PNEUMATIQUES - G1/8
 VÁLVULAS DE ACCIONAMIENTO NEUMÁTICO - G1/8
 VÁLVULAS DE ACIONAMENTO PNEUMÁTICO - G1/8

5/2 Vie - Ways - Wege - Voies - Vías - Vias

New

MONOSTABILE CON RITORNO PNEUMATICO

MONOSTABLE WITH PNEUMATIC RETURN
 MONOSTABIL MIT PNEUMATISCHER RÜCKSTELLUNG
 MONOSTABLE À RAPPEL PNEUMATIQUE
 MONOESTABLE CON RETORNO NEUMÁTICO
 MONOESTÁVEL COM RETORNO PNEUMÁTICO



Codice Code Nummer Code Código Código	Vie Ways Wege Voies Vías Vias	Portata Flow rate Durchflusswert Débit Caudal Vazão	Misura Size Größe Dimension Medida Tamanho	Misura (12) (14) Size Größe Dimension Medida Tamanho
14V P4 5 00 02	5/2	706 NI/min	1/8	M5 x 0.8

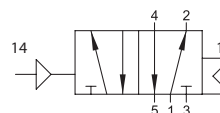

5/2 Vie - Ways - Wege - Voies - Vías - Vias

New

MONOSTABILE CON RITORNO A MOLLA MECCANICA

MONOSTABLE MECHANICAL SPRING RETURN
 MONOSTABIL MIT FEDERRÜCKSTELLUNG
 MONOSTABLE À RAPPEL MECANIQUE PAR RESSORT
 MONOESTABLE CON RETORNO POR MUELLE MECÁNICA
 MONOESTÁVEL COM RETORNO POR MOLA MECÂNICA



* SU RICHIESTA
 * ON REQUEST
 * AUF ANFRAGE
 * ON DEMAND
 * A PETICIÓN
 * A PEDIDO

Codice Code Nummer Code Código Código	Vie Ways Wege Voies Vías Vias	Portata Flow rate Durchflusswert Débit Caudal Vazão	Misura Size Größe Dimension Medida Tamanho	Misura (12) (14) Size Größe Dimension Medida Tamanho
14V P0 5 00 02	5/2	706 NI/min	1/8	M5 x 0.8

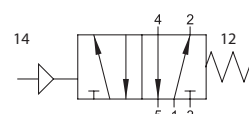

14V P4 5 00 02 14V P0 5 00 02

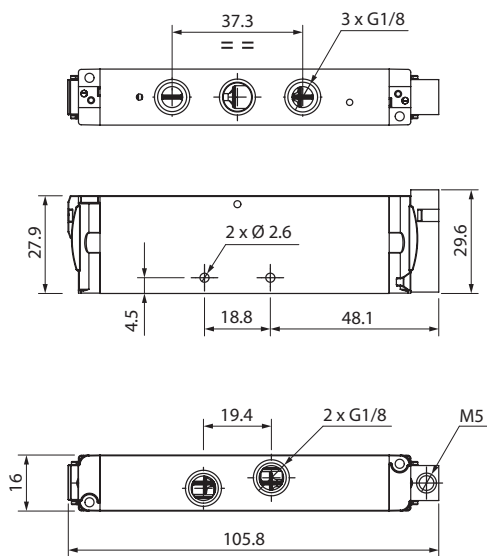

5/2 Vie - Ways - Wege - Voies - Vías - Vias

New

BISTABILE

TWO STABLE POSITIONS

BISTABIL

BISTABLE

BIESTABLE

BIESTÁVEL



Codice Code Nummer Code Código Código	Vie Ways Wege Voies Vías Vias	Portata Flow rate Durchflusswert Débit Caudal Vazão	Misura Size Größe Dimension Medida Tamanho	Misura (12) (14) Size Größe Dimension Medida Tamanho
14V P1 5 00 02	5/2	706 NI/min	1/8	M5 x 0.8

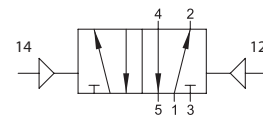

14V P1 5 00 02

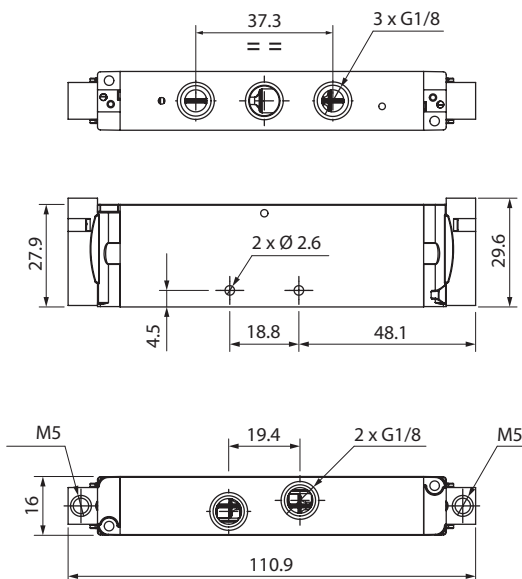

5/3 Vie - Ways - Wege - Voies - Vias - Vias

New

MONOSTABILE CON RITORNO A MOLLA MECCANICA

MONOSTABLE MECHANICAL SPRING RETURN

MONOSTABIL MIT FEDERRÜCKSTELLUNG

MONOSTABLE À RAPPEL MECANIQUE PAR RESSORT

MONOESTABLE CON RETORNO POR MUELLE MECÁNICO

MONOESTÁVEL COM RETORNO POR MOLA MECÂNICA



Codice Code Nummer Code Código Código	Vie Ways Wege Voies Vias Vias	Funzione Function Funktion Fonction Función Funções	Portata Flow rate Durchflusswert Débit Caudal Vazão	Misura Size Größe Dimension Medida Tamanho	Misura (12) (14) Size Größe Dimension Medida Tamanho
14V P0 7 CC 02	5/3	CC	591 NI/min	1/8	M5 x 0.8
14V P0 7 OC 02	5/3	OC	705 NI/min	1/8	M5 x 0.8
14V P0 7 PC 02	5/3	PC	680 NI/min	1/8	M5 x 0.8

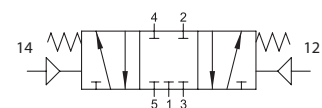

CC

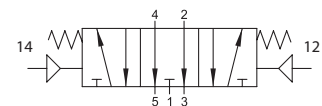

OC

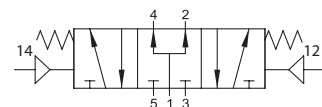

PC

14V P0 7 CC 02 14V P0 7 OC 02 14V P0 7 PC 02

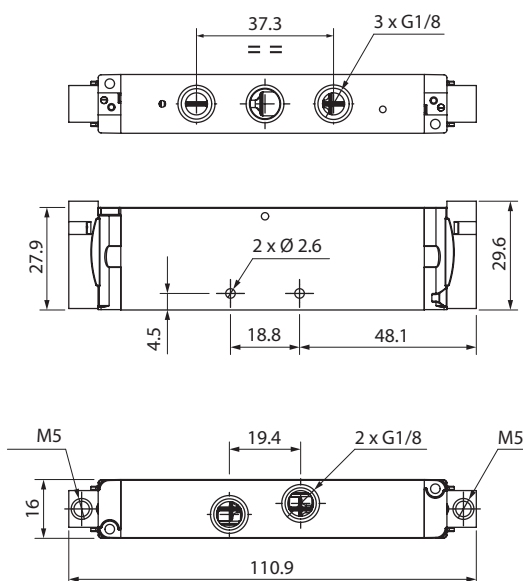

5/4 Vie - Ways - Wege - Voies - Vías - Vias

DOPPIA 3/2 MONOSTABILE CON RITORNO A MOLLA MECCANICA

DOUBLE 3/2 MONOSTABLE MECHANICAL SPRING RETURN

MONOSTABILES 3/2-WEGE-DOPPELVENTIL MIT MECHANISCHER FEDERRÜCKSTELLUNG

DOUBLE 3/2 A RAPPET MECANIQUE PAR RESSORT

DOBLE 3/2 MONOESTABLE CON RETORNO POR MUELLE MECÁNICO

ELETRO-VÁLVULA DUPLA (2 VÁLVULAS 3/2 VIAS) RETORNO MOLA MECÂNICA

New



Code Code Nummer Code Código Código	Vie Ways Wege Voies Vías Vias	Funzione Function Funktion Fonction Función Funções	Portata Flow rate Durchflusswert Débit Caudal Vazão	Misura Size Größe Dimension Medida Tamanho	Misura (12) (14) Size Größe Dimension Medida Tamanho
14V P0 8 NC 02	5/4	NC	553 NI/min	1/8	M5 x 0.8
14V P0 8 NO 02	5/4	NO	620 NI/min	1/8	M5 x 0.8
14V P0 8 NN 02	5/4	NC-NO	553 NI/min	1/8	M5 x 0.8

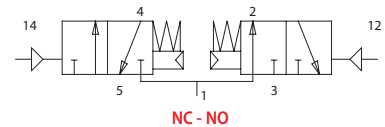
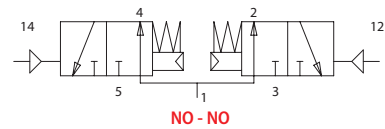
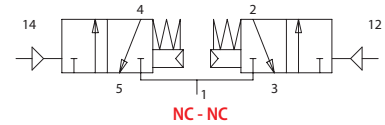

14V P0 8 CC 02 14V P0 8 OC 02 14V P0 8 PC 02

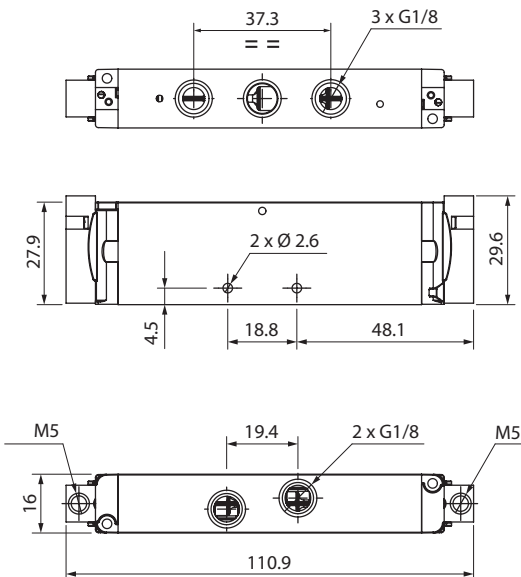

14V06

TAPPO DI CHIUSURA

PLUG FOR UNUSED POSITIONS
 ABDECKPLATTE
 BOUCHON DE FERMETURE
 PLACA DE CIERRE
 PLACA CEGA



Codice Code Nummer Code Código Código	Coppia di serraggio delle viti Screw tightening torque Anzugsdrehmoment der Schrauben Couple de serrage des vis Par de apriete de los tornillos Torque de aperto do parafuso	Peso Weight Gewicht Poids Peso Peso
--	---	--

14V 06 00 11 00 00 (A) 0.6 N 118.5 g

14V 06 00 11 00 00

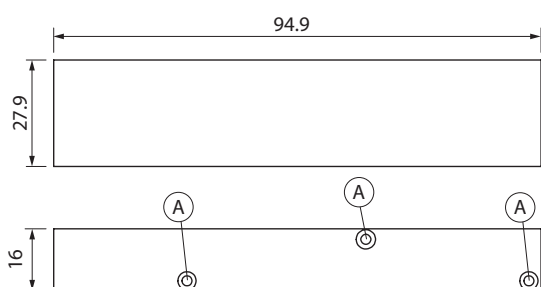

16V39

TAPPO DI SEPARAZIONE PER CONDOTTI DI ALIMENTAZIONE E SCARICO

SEPARATION CAP FOR SUPPLY AND EXHAUST DUCTS
 TRENNKAPPE FÜR ZU- UND ABLUFTKANÄLE
 CAPUCHON DE SÉPARATION POUR LES CONDUITS D'ALIMENTATION ET D'ÉVACUATION
 TAPA DE SEPARACIÓN PARA CONDUCTOS DE ALIMENTACIÓN Y ESCAPE
 TAMPA DE SEPARAÇÃO PARA DUTOS DE ALIMENTAÇÃO E EXAUSTÃO

Codice Code Nummer Code Código Código	Coppia di serraggio delle viti Screw tightening torque Anzugsdrehmoment der Schrauben Couple de serrage des vis Par de apriete de los tornillos Torque de aperto do parafuso	Peso Weight Gewicht Poids Peso Peso
--	---	--

16V 39 0 00 00 0.6 N 4.3 g

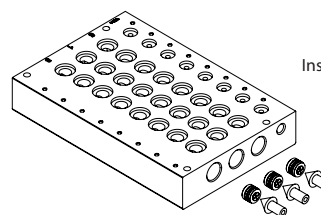

Insert the separating plug

È previsto il sezionamento dell'unità in 2 zone

The unit should be divided into two sections.
 Die Einheit sollte in zwei Zonen unterteilt werden.
 L'unité doit être divisée en deux zones.
 La unidad debe dividirse en dos zonas.
 A unidade deve ser dividida em duas zonas.

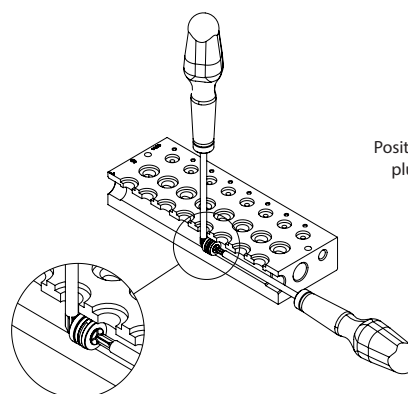

Position the separating plug and tighten the screw to secure it

BASI PNEUMATICHE

PNEUMATIC BASES
PNEUMATISCHE GRUNDPLATTEN
BASES PNEUMATIQUES
BASES NEUMÁTICAS
BASES PNEUMÁTICAS

14VB0

BASE PNEUMATICA
PNEUMATIC BASE
PNEUMATISCHE GRUNDPLATTE
BASE PNEUMATIQUE
BASE NEUMÁTICA
BASE PNEUMÁTICA

New



Codice Code Nummer Code Código Código	Filetto (1) (3) (5) Thread (1) (3) (5) Gewinde (1) (3) (5) Filetage (1) (3) (5) Rosca (1) (3) (5) Rosca (1) (3) (5)	N° Posizioni Positions number Position Nr. Número emplacement Número de puestos N° Posición	L1	L2	Peso Weight Gewicht Poids Peso Peso
14VB0 00 002	1/4	2	51.5	42.5	300 g
14VB0 00 003	1/4	3	68	59	399 g
14VB0 00 004	1/4	4	84.5	75.5	498 g
14VB0 00 005	1/4	5	101	92	597 g
14VB0 00 006	1/4	6	117.5	108.5	696 g
14VB0 00 007	1/4	7	134	125	795 g
14VB0 00 008	1/4	8	150.5	141.5	895 g
14VB0 00 009	1/4	9	167	158	994 g
14VB0 00 010	1/4	10	183.5	174.5	1093 g



<p>IT</p> <p>Le basi sono fornite complete di viti e O-Ring per il fissaggio delle valvole.</p>	<p>GB</p> <p>The bases are supplied with screws and O-Ring for attachment of the valves.</p>	<p>DE</p> <p>Die Grundplatten werden mit Schrauben und O-Ringen zur Befestigung der Ventile geliefert.</p>
<p>FR</p> <p>Les embases sont fournies avec les vis et les joints toriques pour la fixation des distributeurs.</p>	<p>ES</p> <p>Las bases vienen suministradas con tornillos y tóricas para el montaje.</p>	<p>PT</p> <p>As base são fornecidas completas com parafusos e O-Ring para fixação das válvulas.</p>

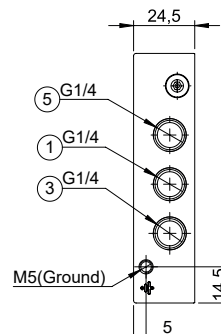
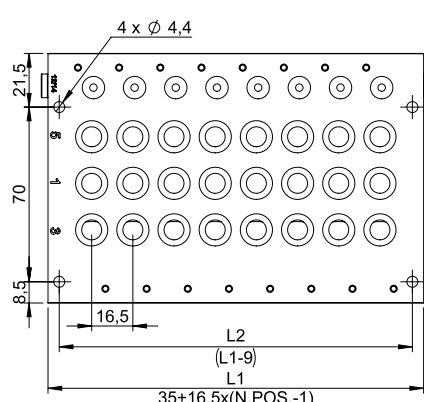

1	<p>Alimentazione Air supply Luftversorgung Alimentation Alimentación Alimentação</p>
----------	---

3/5	<p>Scarichi Exhaust Abluft Echappement Escapes Escape</p>
------------	--

ACCESSORI

ACCESSORIES
BEFESTIGUNGSELEMENTE
ACCESSOIRES
ACCESORIOS
ACESSÓRIOS

50015N

RACCORDO DIRITTO MASCHIO CILINDRICO ESAGONO INCASSATO

STRAIGHT MALE ADAPTOR (PARALLEL) WITH HEXAGON EMBEDDED
GERADE EINSCHRAUBVERSCHRAUBUNG MIT INNENSECHSKANT ZYLINDRISCH
RACCORD DROIT MÂLE, CYLINDRIQUE, 6-PANS INTERIEUR
RACOR RECTO MACHO CILÍNDRICO CON TÓRICA HEXÁGONO INTERIOR
CONEXÃO RETA COM SEXTAVADO INTERNO E ROSCA MÉTRICA

Code	Tube	A	B	C	L	CH	Pack.
50015 00 N03	6	1/8	5.4	12.8	23	4	10
50015 00 N04	8	1/8	5.4	14	26	5	10

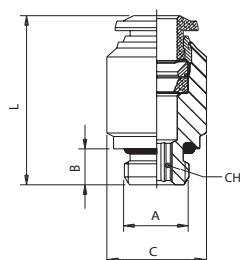

50610

TAPPO IN POLIAMIDE

POLYAMIDE PLUG
VERSCHLUSSZAPFEN POLYAMID
BOUCHON EN POLYAMIDE
TAPÓN EN POLIAMIDA
TAMPÃO EM POLIAMIDA

Code	ØD1	G	L	L1	Pack.
50610 00 31 X4 RO	6	8	32	15.5	10
50610 00 31 X7 RO	8	10	35.5	19.5	10

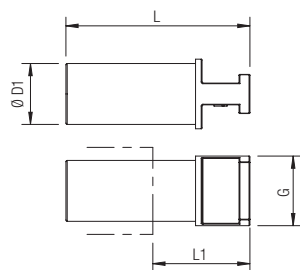

55140

RACCORDO A L CON CODA LISCIATA CORTA

ORIENTING ELBOW
WINKELSTECKVERSCHRAUBUNG KURZ
RACCORD EQUERRE ENCLIQUETABLE
RACOR A L ORIENTABLE CON ESPIGA LISA CORTA
CONEXÃO EM "L" COM PONTA LISA E CURTA

Code	Tube	A	B	L1	L2	CH1	D	Pack.
55140 00 002	4	6	19	16.5	22.8	7	10	10
55140 00 005	6	6	19	20.5	23.7	9	12.5	10
55140 00 007	8	8	20	22	26	10	14	10

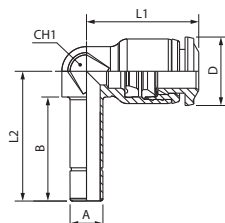

55150

RACCORDO A L CON CODA LISCIA LUNGA

ORIENTING ELBOW

WINKELSTECKERVERSCHRAUBUNG LANG

RACCORD EQUERRE ENCLIQUETABLE, RALLONGÉ

RACOR A L ORIENTABLE CON ESPIGA LISA LARGA

CONEXÃO EM "L" COM PONTA LISA E LONGA

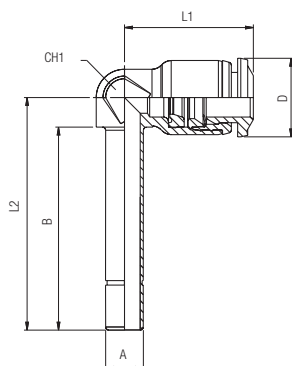

Code	Tube	A	B	L1	L2	CH1	D	Pack.
55150 00 002	4	6	30.5	16.5	34.3	7	10	10
55150 00 005	6	6	32.3	20.5	37	9	12.5	10
55150 00 007	8	8	36	22	42	10	14	10

PX__0

CAVO DI ALIMENTAZIONE CON CONNETTORE DIRITTO FEMMINA M8X1

CABLE WITH INLINE FEMALE CONNECTOR M8X1

KOMMUNIKATIONSKABEL MIT INLINE-KUPPLUNG M8X1

CABLE DE COMMUNICATION CONNECTEUR DIRECT FEMELLE M8X1

CABLE DE COMUNICACIÓN CONECTOR RECTO HEMBRA M8X1

CABO DE COMUNICAÇÃO COM CONECTOR RETO M8X1 FÊMEA

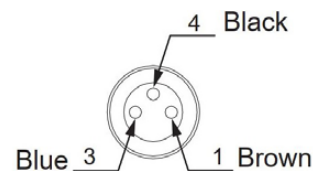
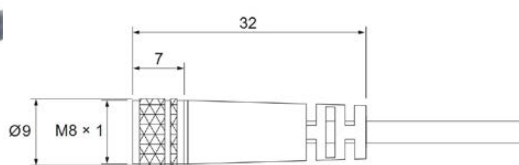

Codice Code Nummer Code Código Código	Lunghezza cavo Cable Length Kabellänge Longueur cable Longitud cable Comprimento	Materiale guaina Jacket Material Werkstoff Kabelmantel Matériau de la gaine Material vaina Material capa	Pack.
PX 2000 PUR	2 m	PUR	1
PX 5000 PUR	5 m	PUR	1

max



Torque specifications ring

0.4 Nm

PX__1

CAVO DI ALIMENTAZIONE CON CONNETTORE A "L" FEMMINA M8X1

CABLE WITH "L" FEMALE CONNECTOR M8X1

KOMMUNIKATIONSKABEL MIT "L"-BUCHSE M8X1

CABLE DE COMMUNICATION CONNECTEUR "L" FEMELLE M8X1

CABLE DE COMUNICACIÓN CONECTOR "L" HEMBRA M8X1

CABO DE COMUNICAÇÃO COM CONECTOR "L" M8X1 FÊMEA

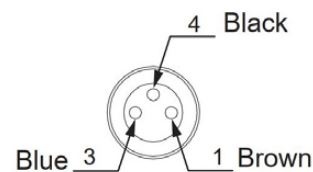
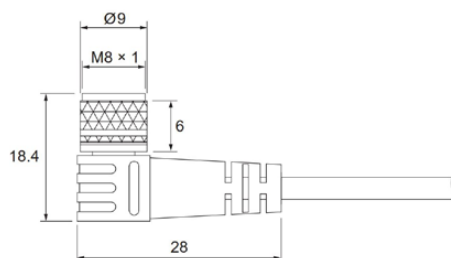

Codice Code Nummer Code Código Código	Lunghezza cavo Cable Length Kabellänge Longueur cable Longitud cable Comprimento	Materiale guaina Jacket Material Werkstoff Kabelmantel Matériau de la gaine Material vaina Material capa	Pack.
PX 20001 PUR	2 m	PUR	1
PX 50001 PUR	5 m	PUR	1

max



Torque specifications ring

0.4 Nm