

SERIE 120 UNI ISO 6150 B-12



CARATTERISTICHE TECNICHE
 TECHNICAL CHARACTERISTICS
 TECHNISCHE ANGABEN
 CARACTÉRISTIQUES TECHNIQUES
 CARACTERÍSTICAS TÉCNICAS
 CARACTERÍSTICAS TÉCNICAS



Norma di Riferimento

Reference standard

Entspricht der Norm

Norme de référence

Normativa de referencia

Norma de referência

1907/2006
 REACH ✓

2011/65/CE
 RoHS ✓

PED
 2014/68/UE

SILICON
 FREE

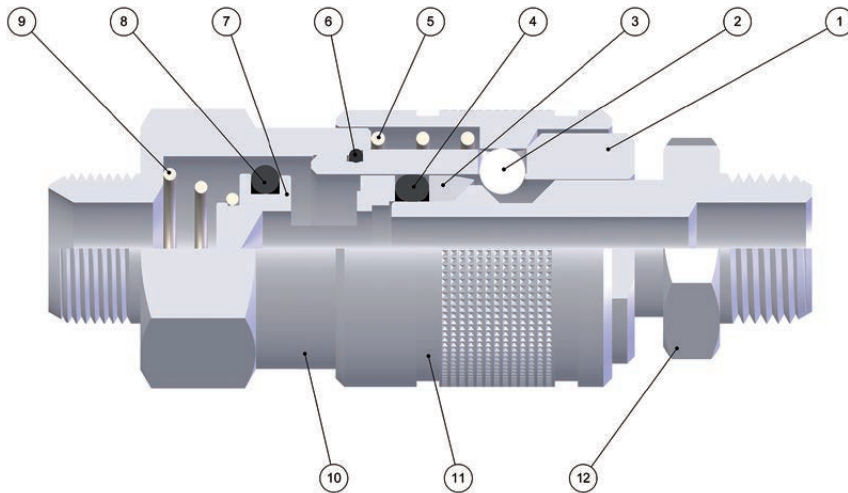

FKM A RICHIESTA
 IF REQUESTED FKM
 FKM AUF ANFRAGE
 FKM SUR DEMANDE
 FKM BAJO DEMANDA
 FKM SOB ENCOMENDA

DN
 5.5 mm

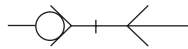

UNI ISO 6150 B-12

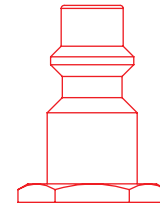

1:1

Materiali e Componenti

IT

- 1 Corpo in Ottone Nichelato
- 2 Sfera in Acciaio AISI 420
- 3 Anello Guida innesto in Ottone Nichelato
- 4 Guarnizione O-Ring in NBR
- 5 Molla Ghiera in Acciaio AISI 302
- 6 Guarnizione O-Ring in NBR
- 7 Otturatore in Ottone Nichelato
- 8 Guarnizione O-Ring in NBR 70
- 9 Molla Otturatore in Acciaio AISI 302
- 10 Attacco Terminale in Ottone Nichelato
- 11 Ghiera in Ottone Nichelato
- 12 Innesto in Ottone Nichelato

Component Parts and Materials

GB

- 1 Nickel-Plated Brass Body
- 2 Stainless Steel AISI 420 Balls
- 3 Nickel-Plated Brass Guide Ring Coupling
- 4 NBR O-Ring Seals
- 5 Stainless Steel AISI 302 Ring Nut Spring
- 6 NBR O-Ring Seals
- 7 Nickel-Plated Brass Shutter
- 8 NBR 70 O-Ring Seals
- 9 Stainless Steel AISI 302 Shutter Spring
- 10 Nickel-Plated Brass Coupling Back Part
- 11 Nickel-Plated Brass Sleeve
- 12 Nickel-Plated Brass Plug Outline

Komponenten und Materialien

DE

- 1 Körper Messing Vernickelt
- 2 Kugel Edelstahl AISI 420
- 3 Stecker Führungsring Messing Vernickelt
- 4 O-Ring NBR
- 5 Entriegelungsfeder Edelstahl AISI 302
- 6 O-Ring NBR
- 7 Verschluss Messing Vernickelt
- 8 O-Ring NBR
- 9 Verschlussfeder Edelstahl AISI 302
- 10 Einschraubkörper Messing Vernickelt
- 11 Entriegelungshülse Messing Vernickelt
- 12 Stecker Messing Vernickelt

Matériaux et Composants

FR

- 1 Corps: Laiton Nickelé
- 2 Bille: Acier Inoxydable AISI 420
- 3 Bague de Guidage: Laiton Nickelé
- 4 Joint Torique en NBR
- 5 Ressort de Bague: Acier Inoxydable AISI 302
- 6 Joint Torique en NBR
- 7 Clapet: Laiton Nickelé
- 8 Joint Torique en NBR
- 9 Ressort de Clapet: Acier Inoxydable AISI 302
- 10 Corps: Laiton Nickelé
- 11 Bague: Laiton Nickelé
- 12 Embout: Laiton Nickelé

Materiales y Componentes

ES

- 1 Cuerpo en latón niquelado
- 2 Esfera en acero AISI 420
- 3 Anillo guía enchufe en latón niquelado
- 4 Junta tórica en NBR
- 5 Muelle tuerca en acero AISI 302
- 6 Junta tórica en NBR
- 7 Obturador en latón niquelado
- 8 Junta tórica en NBR 70
- 9 Muelle obturador en acero AISI 302
- 10 Terminal de conexión en latón niquelado
- 11 Tuerca en latón niquelado
- 12 Enchufe en latón niquelado

Materiais e Componentes

PT

- 1 Corpo em Latão Niquelado
- 2 Esfera em aço AISI 420
- 3 Anel guia do plug em latão niquelado
- 4 Vedação O-Ring em NBR
- 5 Mola da porca em aço AISI 302
- 6 Vedação O-Ring em NBR
- 7 Obturador em latão niquelado
- 8 Vedação O-Ring em NBR 70
- 9 Mola do obturador em aço AISI 302
- 10 Conexão terminal em latão niquelado
- 11 Porca em latão niquelado
- 12 Plug em latão niquelado



Pressione d'esercizio

Working Pressures

Betriebsdruck

Pression de service

Presión de Ejercicio

Pressão de Trabalho

0 bar

16 bar



Max pressione statica (no pulsazioni)

Maximum static pressure (no pulsations)

Maximaler statischer Betriebsdruck (ohne pulsations)

Pression statique maximale (sans pulsation)

Presión estática máxima (sin pulsaciones)

Pressão estática máxima (sem pulsações)

35 bar



Temperature

Temperatures

Temperatur

Températures

Temperaturas

Temperaturas

- 20 °C

+ 80 °C

Con O-ring in FKM

With FKM O-ring

Mit O-ring in FKM

Avec joints en FKM

Con junta tórica en FKM

Com O-ring em FKM

- 10 °C

+ 200 °C



Fluidi compatibili

Aria compressa

Fluids

Compressed air

Geeignete Medien

Druckluft

Fluides compatibles

Air comprimé

Fluidos compatibles

Aire comprimido

Fluidos compatíveis

Ar comprimido

Per altri fluidi, consultare l'ufficio tecnico Aignep.

For other fluids, consult the technical department Aignep.

Für andere Flüssigkeiten, kontaktieren Sie uns.

Pour d'autres fluides, veuillez nous consulter.

Para otros fluidos póngase en contacto con el departamento técnico Aignep.

Para outros fluidos consulte o departamento técnico da Aignep.



Portata

NI/min

Flow Rate

Durchflusswerte

Débit

Caudal de Flujo

Vazão

6 bar Δ 1	6 bar Δ 0.5	6 bar *
1100	800	1500

* Scarico libero - Exhaust Free - Freier Auslass - Échappement libre - Escape Libre - Descarga livre.



Filettatura

IT

Gas cilindrica conforme ISO 228 Classe A.

Threads

GB

Parallel gas in conformity with ISO 228 Class A.

Gewindearten

DE

Zylindrisches Gewinde nach Norm ISO 228 Classe A.

Filetages

FR

Filetage cylindrique conforme: ISO 228 Class A.

Roscas

ES

Gas cilindrica conforme ISO 228 Clase A.

Roscas

PT

Gas paralela conforme ISO 228 Classe A.

121

PRESA MASCHIO

MALE SOCKET

VERSCHLUSS-KUPPLUNG MIT AUSSENGEWINDE

COUPLEUR MÂLE

ENCHUFE MACHO

SOQUETE COM ROSCA MACHO

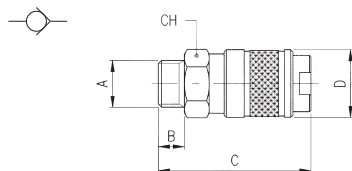

Code	A	B	C	D	CH	Pack.
00121 00 001	1/4	8	53	24	21	10
00121 00 002	3/8	9	54	24	21	10
00121 00 003	1/2	10	55	24	24	10

122

PRESA FEMMINA

FEMALE SOCKET

VERSCHLUSS-KUPPLUNG MIT INNENGEWINDE

COUPLEUR FEMELLE

ENCHUFE HEMBRA

SOQUETE COM ROSCA FÊMEA

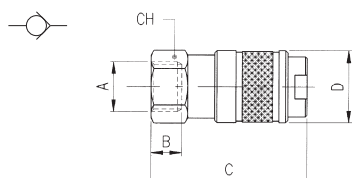

Code	A	B	C	D	CH	Pack.
00122 00 001	1/4	11	55	24	21	10
00122 00 002	3/8	11.5	55.5	24	21	10
00122 00 003	1/2	14	59	24	24	10

123

PRESA A CALZAMENTO CON MOLLA

COMPRESSION SOCKET WITH SPRING

VERSCHLUSS-KUPPLUNG MIT KNICKSCHUTZFEDER

COUPLEUR AVEC RESSORT DE PROTECTION

ENCHUFE TUBO CON MUELLE

SOQUETE COM CONEXÃO PUSH-ON COM MOLLA

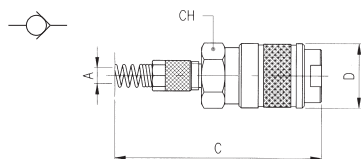

Code	A	C	D	CH	Pack.
00123 00 001	6/4	141	24	21	10
00123 00 002	8/6	146.5	24	21	10
00123 00 003	10/8	154	24	21	10

Molla Acciaio Inox AISI 304 - EN 1.4301
 Stainless Steel Spring AISI 304 - EN 1.4301
 Edelstahlfeder AISI 304 - EN 1.4301
 Ressort Acier Inoxydable AISI 304 - EN 1.4301
 Muelle Acero Inoxidable AISI 304 - EN 1.4301
 Mola Aço Inoxidável AISI 304 - EN 1.4301

124

PRESA A CALZAMENTO

COMPRESSION SOCKET

VERSCHLUSS-KUPPLUNG MIT ÜBERWURFVERSCHRAUBUNG

COUPLEUR RACCORD À COIFFE

ENCHUFE TUBO

SOQUETE COM CONEXÃO PUSH-ON

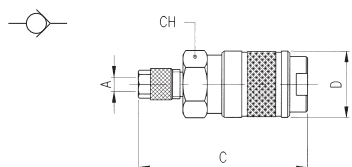

Code	A	C	D	CH	Pack.
00124 00 001	6/4	59	24	21	10
00124 00 002	8/6	59	24	21	10
00124 00 003	10/8	60	24	21	10

125

PRESA CON PORTAGOMMA A RESCA

BARBED SOCKET

VERSCHLUSS-KUPPLUNG MIT SCHLAUCHTÜLLE

COUPLEUR À DOUILLE ANNELÉE POUR TUBE

ENCHUFE ESPIGA

SOQUETE COM ESPIGÃO PARA MANGUEIRA DE BORRACHA

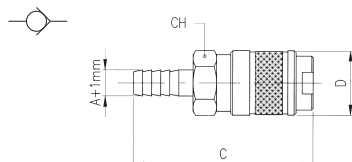

Code	A	C	D	CH	Pack.
00125 00 001	6	64	24	21	10
00125 00 002	8	64	24	21	10
00125 00 003	10	64	24	21	10
00125 00 004	12	64	24	21	10

126

PRESA CON PORTAGOMMA

SOCKET FOR RUBBER HOSE

VERSCHLUSS-KUPPLUNG FÜR GUMMISCHLAUCH

COUPLEUR POUR TUBE

ENCHUFE CON PORTAGOMA

SOQUETE COM ESPIGÃO PARA TUBO DE BORRACHA

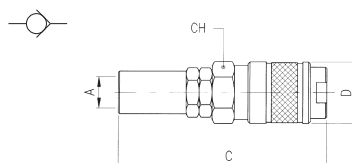

Code	A	C	D	CH	Pack.
00126 00 001	14/6	72	24	21	10
00126 00 002	17/8	72	24	21	10
00126 00 003	19/10	72	24	21	10

221

INNESTO MASCHIO

MALE PLUG

STECKER MIT AUSSENGEWINDE

EMBOUT MÂLE

ADAPTADOR MACHO

PLUG COM ROSCA MACHO

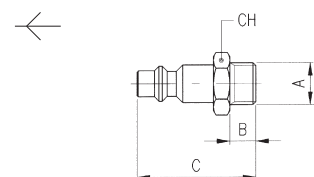

Code	A	B	C	CH	Pack.
00221 00 01 03 NB	1/4	8	36.5	17	10
00221 00 01 04 NB	3/8	9	37.5	19	10
00221 00 01 05 NB	1/2	10	39	24	10

221AC

INNESTO IN ACCIAIO MASCHIO

STEEL MALE PLUG

STECKER MIT AUSSENGEWINDE AUS STAHL

EMBOUT MÂLE EN ACIER

ADAPTADOR EN ACERO MACHO

PLUG EM AÇO COM ROSCA MACHO

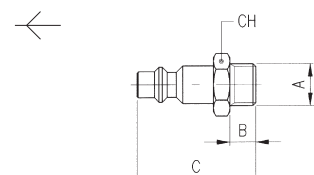

Code	A	B	C	CH	Pack.
221AC 00 51 03 ZI	1/4	8	36.5	17	10
221AC 00 51 04 ZI	3/8	9	37.5	19	10
221AC 00 51 05 ZI	1/2	10	39	24	10

Acciaio Indurito
 Hardened Steel
 Gehärtetem Stahl
 Acier Trempé
 Acero Curtido
 Aço Endurecido

222

INNESTO FEMMINA

FEMALE PLUG
 STECKER MIT INNENGEWINDE
 EMBOUT FEMELLE
 ADAPTADOR HEMBRA
 PLUG COM ROSCA FÊMEA

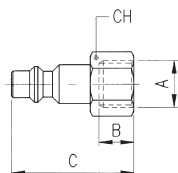

Code	A	B	C	CH	Pack.
00222 00 01 03 NB	1/4	11	36.5	17	10
00222 00 01 04 NB	3/8	11.5	37	19	10
00222 00 01 05 NB	1/2	15	40.5	24	10

222AC

INNESTO IN ACCIAIO FEMMINA

STEEL FEMALE PLUG
 STECKER MIT INNENGEWINDE AUS STAHL
 EMBOUT FEMELLE EN ACIER
 ADAPTADOR EN ACERO HEMBRA
 PLUG EM AÇO COM ROSCA FÊMEA

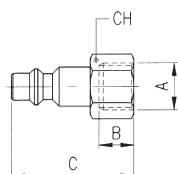

Code	A	B	C	CH	Pack.
222AC 00 51 03 ZI	1/4	11	36.5	17	10
222AC 00 51 04 ZI	3/8	11.5	37	19	10
222AC 00 51 05 ZI	1/2	15	40.5	24	10

Acciaio Indurito
 Hardened Steel
 Gehärtetem Stahl
 Acier Trempé
 Acero Curtido
 Aço Endurecido

223

INNESTO A CALZAMENTO CON MOLLA

COMPRESSION PLUG WITH SPRING
 STECKER MIT KNICKSCHUTZFEDER
 EMBOUT AVEC RESSORT DE PROTECTION
 ADAPTADOR TUBO CON MUELLE
 PLUG COM CONEXÃO PUSH-ON COM MOLA

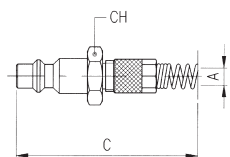

Code	A	C	CH	Pack.
00223 00 001	6/4	123	13	10
00223 00 002	8/6	128.5	13	10
00223 00 003	10/8	136	14	10
00223 00 004	12/10	142	16	10

Molla Acciaio Inox AISI 304 - EN 1.4301
 Stainless Steel Spring AISI 304 - EN 1.4301
 Edelstahlfeder AISI 304 - EN 1.4301
 Ressort Acier Inoxydable AISI 304 - EN 1.4301
 Muelle Acero Inoxidable AISI 304 - EN 1.4301
 Mola Aço Inoxidável AISI 304 - EN 1.4301

224

INNESTO A CALZAMENTO

COMPRESSION PLUG
 STECKER MIT ÜBERWURFVERSCHRAUBUNG
 EMBOUT À RACCORD À COIFFE
 ADAPTADOR TUBO
 PLUG COM CONEXÃO PUSH-ON

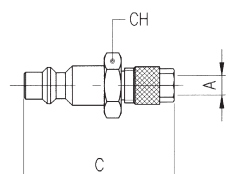

Code	A	C	CH	Pack.
00224 00 001	6/4	41	13	10
00224 00 002	8/6	41	13	10
00224 00 003	10/8	43	14	10
00224 00 004	12/10	45	16	10

225

INNESTO CON PORTAGOMMA A RESCA

BARBED PLUG
 STECKER MIT SCHLAUCHTÜLLE
 EMBOUT À DOUILLE ANNELÉE POUR TUBE
 ADAPTADOR ESPIGA
 PLUG COM ESPIGÃO PARA TUBO DE BORRACHA

Code	A	C	D	Pack.
00225 00 01 X4 NB	6	43.5	12	10
00225 00 01 X7 NB	8	43.5	12	10
00225 00 01 X9 NB	10	46	14	10
00225 00 01 Y1 NB	12	46	16	10

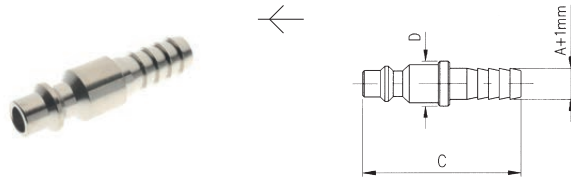

225AC

INNESTO IN ACCIAIO CON PORTAGOMMA A RESCA

STEEL BARBED PLUG
 STECKER MIT SCHLAUCHTÜLLE AUS STAHL
 EMBOUT À DOUILLE ANNELÉE POUR TUBE EN ACIER
 ADAPTADOR EN ACERO ESPIGA
 PLUG EM AÇO COM ESPIGÃO PARA TUBO DE BORRACHA

Code	A	C	D	Pack.
225AC 00 51 X4 ZI	6	43.5	12	10
225AC 00 51 X7 ZI	8	43.5	12	10
225AC 00 51 X9 ZI	10	46	14	10
225AC 00 51 Y1 ZI	12	46	16	10

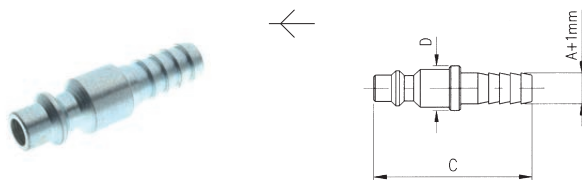

Acciaio Indurito
 Hardened Steel
 Gehärtetem Stahl
 Acier Trempé
 Acero Curtido
 Aço Endurecido

227

INNESTO A BAIONETTA

BAYONET PLUG
 STECKER MIT BAJONETT-VERSCHLUSS
 EMBOUT À RACCORD À BAIONNETTE
 ADAPTADOR BAYONETA
 PLUG COM CONEXÃO TIPO BAIONETA

Code	A	C	CH	Pack.
00227 00 001	15	37	15	10

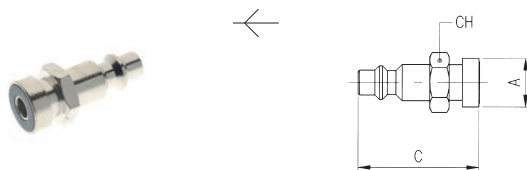

228

INNESTO A SCARICO PROGRESSIVO

PLUG WITH GRADUAL EXHAUST
 STECKER MIT PROGRESSIVER ENTLASTUNG
 EMBOUT À PASSAGE PROGRESSIF
 ADAPTADOR DE DESCARGA PROGRESIVA
 PLUG COM ESCAPE PROGRESSIVO

Code	A	B	C	CH	Pack.
00228 00 001	1/4	11	45	17	10

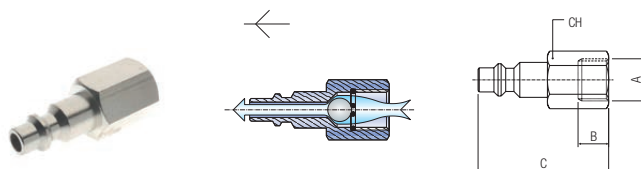

SERIE 120 ITALIAN PROFILE



CARATTERISTICHE TECNICHE
 TECHNICAL CHARACTERISTICS
 TECHNISCHE ANGABEN
 CARACTÉRISTIQUES TECHNIQUES
 CARACTERÍSTICAS TÉCNICAS
 CARACTERÍSTICAS TÉCNICAS



Norma di Riferimento

Reference standard

Entspricht der Norm

Norme de référence

Normativa de referencia

Norma de referência

1907/2006
REACH ✓

2011/65/CE
RoHS ✓

PED
2014/68/UE

SILICON
FREE

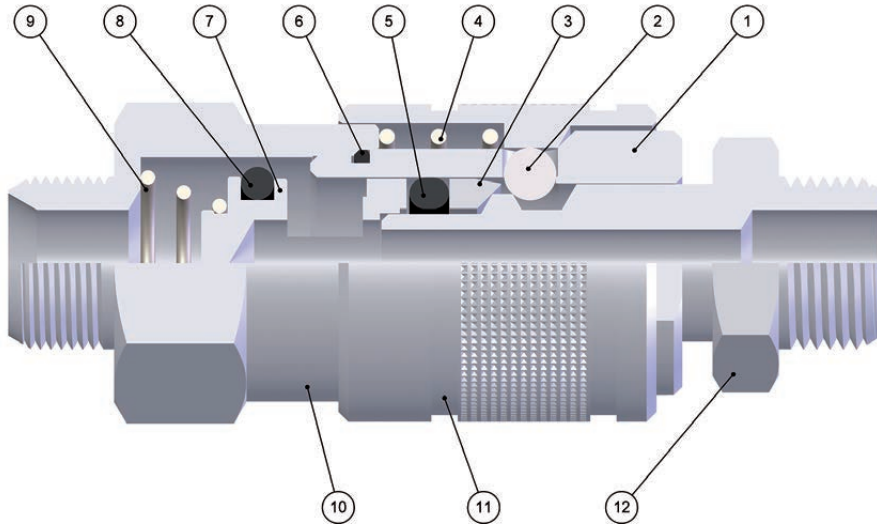

FKM A RICHIESTA
 IF REQUESTED FKM
 FKM AUF ANFRAGE
 FKM SUR DEMANDE
 FKM BAJO DEMANDA
 FKM SOB ENCOMENDA

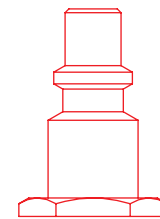
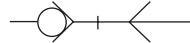

1:1

Materiali e Componenti	IT	Component Parts and Materials	GB	Komponenten und Materialien	DE
1 Corpo in Ottone Nichelato		1 Nickel-Plated Brass Body		1 Körper Messing Vernickelt	
2 Sfere in Acciaio AISI 420		2 Stainless Steel AISI 420 Balls		2 Kugel Edelstahl AISI 420	
3 Anello Guida Innesto in Ottone Nichelato		3 Nickel-Plated Brass Guide Ring Coupling		3 Stecker Führungsring Messing Vernickelt	
4 Molla Ghiera in Acciaio AISI 302		4 Stainless Steel AISI 302 Ring Nut Spring		4 Entriegelungsfeder Edelstahl AISI 302	
5 Guarnizione O-Ring in NBR		5 NBR O-Ring Seals		5 O-Ring NBR	
6 Guarnizione O-Ring in NBR		6 NBR O-Ring Seals		6 O-Ring NBR	
7 Otturatore in Ottone Nichelato		7 Nickel-Plated Brass Shutter		7 Verschluss Messing Vernickelt	
8 Guarnizione O-Ring in NBR		8 NBR O-Ring Seals		8 O-Ring NBR	
9 Molla Otturatore in Acciaio AISI 302		9 Stainless Steel AISI 302 Shutter Spring		9 Verschlussfeder Edelstahl AISI 302	
10 Attacco Terminale in Ottone Nichelato		10 Nickel-Plated Brass Coupling Back Part		10 Einschraubkörper Messing Vernickelt	
11 Ghiera in Ottone Nichelato		11 Nickel-Plated Brass Sleeve		11 Entriegelungshülse Messing Vernickelt	
12 Innesto in Ottone Nichelato		12 Nickel-Plated Brass Plug Outline		12 Stecker Messing Vernickelt	

Matériaux et Composants	FR	Materiales y Componentes	ES	Materiais e Componentes	PT
1 Corps: Laiton Nickelé		1 Cuerpo en latón niquelado		1 Corpo em Latão Niquelado	
2 Bille: Acier Inoxydable AISI 420		2 Esfera en acero AISI 420		2 Esfera em aço AISI 420	
3 Bague de Guidage: Laiton Nickelé		3 Anillo guía enchufe en latón niquelado		3 Anel guia do plug em latão niquelado	
4 Ressort de Bague: Acier Inoxydable AISI 302		4 Muelle tuerca en acero AISI 302		4 Mola da porca em aço AISI 302	
5 Joint Torique en NBR		5 Junta tórica en NBR		5 Vedação O-Ring em NBR	
6 Joint Torique en NBR		6 Junta tórica en NBR		6 Vedação O-Ring em NBR	
7 Clapet: Laiton Nickelé		7 Obturador en latón niquelado		7 Obturador em latão niquelado	
8 Joint Torique en NBR		8 Junta tórica en NBR		8 Vedação O-Ring em NBR	
9 Ressort de Clapet: Acier Inoxydable AISI 302		9 Muelle obturador en acero AISI 302		9 Mola do obturador em aço AISI 302	
10 Corps: Laiton Nickelé		10 Terminal de conexión en latón niquelado		10 Conexão terminal em latão niquelado	
11 Bague: Laiton Nickelé		11 Tuerca en latón niquelado		11 Porca em latão niquelado	
12 Embout: Laiton Nickelé		12 Enchufe en latón niquelado		12 Plug em latão niquelado	



Pressione d'esercizio

Working Pressures

Betriebsdruck

Pression de service

Presión de Ejercicio

Pressão de Trabalho

0 bar

16 bar



Max pressione statica (no pulsazioni)

Maximum static pressure (no pulsations)

Maximaler statischer Betriebsdruck (ohne pulsations)

Pression statique maximale (sans pulsation)

Presión estática máxima (sin pulsaciones)

Pressão estática máxima (sem pulsações)

35 bar



Temperature

Temperatures

Temperatur

Températures

Temperaturas

Temperaturas

- 20 °C

+ 80 °C

Con O-ring in FKM

With FKM O-ring

Mit O-ring in FKM

Avec joints en FKM

Con junta tórica en FKM

Com O-ring em FKM

- 10 °C

+ 200 °C



Fluidi compatibili

Aria compressa

Fluids

Compressed air

Geeignete Medien

Druckluft

Fluides compatibles

Air comprimé

Fluidos compatibles

Aire comprimido

Fluidos compatíveis

Ar comprimido

Per altri fluidi, consultare l'ufficio tecnico Aignep.

For other fluids, consult the technical department Aignep.

Für andere Flüssigkeiten, kontaktieren Sie uns.

Pour d'autres fluides, veuillez nous consulter.

Para otros fluidos póngase en contacto con el departamento técnico Aignep.

Para outros fluidos consulte o departamento técnico da Aignep.



Portata

NI/min

Flow Rate

Durchflusswerte

Débit

Caudal de Flujo

Vazão

6 bar

Δ 1

1100

6 bar

Δ 0.5

800

6 bar

1500

* Scarico libero - Exhaust Free - Freier Auslass - Échappement libre - Escape Libre - Descarga livre.



Filettatura

IT

Threads

GB

Gewindearten

DE

Gas cilindrica conforme ISO 228 Classe A.

Parallel gas in conformity with ISO 228 Class A.

Zylindrisches Gewinde nach Norm ISO 228 Classe A.

Filetages

FR

Roscas

ES

Roscas

PT

Filetage cylindrique conforme: ISO 228 Class A.

Gas cilíndrica conforme ISO 228 Classe A.

Gas paralela conforme ISO 228 Classe A.

121

PRESA MASCHIO

MALE SOCKET
MIT AUSSENGEWINDE
COUPLEUR MÂLE
ENCHUFE MACHO
SOQUETE COM ROSCA MACHO

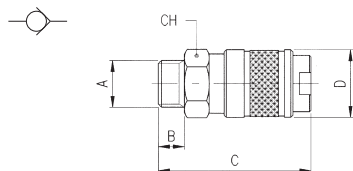

Code	A	B	C	D	CH	Pack.
00121 00 001	1/4	8	53	24	21	10
00121 00 002	3/8	9	54	24	21	10
00121 00 003	1/2	10	55	24	24	10

122

PRESA FEMMINA

FEMALE SOCKET
VERSCHLUSS-KUPPLUNG MIT INNENGEWINDE
COUPLEUR FEMELLE
ENCHUFE HEMBRA
SOQUETE COM ROSCA FÊMEA

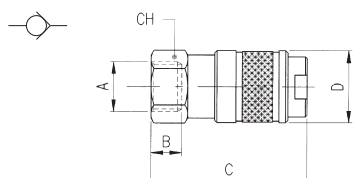

Code	A	B	C	D	CH	Pack.
00122 00 001	1/4	11	55	24	21	10
00122 00 002	3/8	11.5	55.5	24	21	10
00122 00 003	1/2	14	59	24	24	10

123

PRESA A CALZAMENTO CON MOLLA

COMPRESSION SOCKET WITH SPRING
VERSCHLUSS-KUPPLUNG MIT KNICKSCHUTZFEDER
COUPLEUR AVEC RESSORT DE PROTECTION
ENCHUFE TUBO CON MUELLE
SOQUETE COM CONEXÃO PUSH-ON COM MOLA

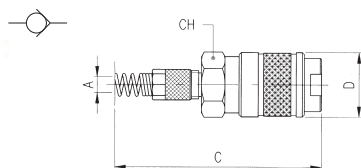

Code	A	C	D	CH	Pack.
00123 00 001	6/4	141	24	21	10
00123 00 002	8/6	146.5	24	21	10
00123 00 003	10/8	154	24	21	10

Molla Acciaio Inox AISI 304 - EN 1.4301
Stainless Steel Spring AISI 304 - EN 1.4301
Edelstahlfeder AISI 304 - EN 1.4301
Ressort Acier Inoxydable AISI 304 - EN 1.4301
Muelle Acero Inoxidable AISI 304 - EN 1.4301
Mola Aço Inoxidável AISI 304 - EN 1.4301

124

PRESA A CALZAMENTO

COMPRESSION SOCKET
VERSCHLUSS-KUPPLUNG MIT ÜBERWURFVERSCHRAUBUNG
COUPLEUR RACCORD À COIFFE
ENCHUFE TUBO
SOQUETE COM CONEXÃO PUSH-ON

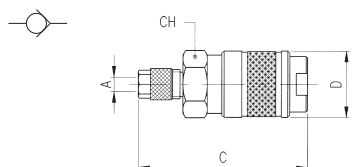

Code	A	C	D	CH	Pack.
00124 00 001	6/4	59	24	21	10
00124 00 002	8/6	59	24	21	10
00124 00 003	10/8	60	24	21	10

125

PRESA CON PORTAGOMMA A RESCA

BARBED SOCKET

VERSCHLUSS-KUPPLUNG MIT SCHLAUCHTÜLLE

COUPLEUR À DOUILLE ANNELÉE POUR TUBE

ENCHUFE ESPIGA

SOQUETE COM ESPIGÃO PARA MANGUEIRA DE BORRACHA

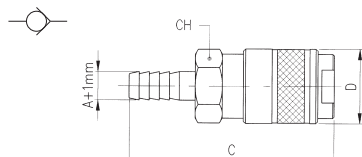

Code	A	C	D	CH	Pack.
00125 00 001	6	64	24	21	10
00125 00 002	8	64	24	21	10
00125 00 003	10	64	24	21	10
00125 00 004	12	64	24	21	10

126

PRESA CON PORTAGOMMA

SOCKET FOR RUBBER HOSE

VERSCHLUSS-KUPPLUNG FÜR GUMMISCHLAUCH

COUPLEUR À DOUILLE POUR TUBE

ENCHUFE CON PORTAGOMA

SOQUETE COM ESPIGÃO PARA TUBO DE BORRACHA

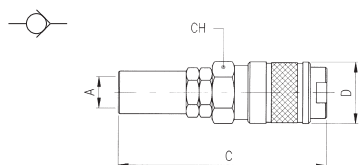

Code	A	C	D	CH	Pack.
00126 00 001	14/6	72	24	21	10
00126 00 002	17/8	72	24	21	10
00126 00 003	19/10	72	24	21	10

251

INNESTO MASCHIO

MALE PLUG

STECKER MIT AUSSENGEWINDE

EMBOUT MÂLE

ADAPTADOR MACHO

PLUG COM ROSCA MACHO

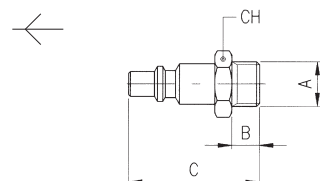

Code	A	B	C	CH	Pack.
00251 00 01 03 NB	1/4	8	38	17	10
00251 00 01 04 NB	3/8	9	39	19	10
00251 00 01 05 NB	1/2	10	40.5	24	10

251AC

INNESTO IN ACCIAIO MASCHIO

STEEL MALE PLUG

STECKER MIT AUSSENGEWINDE AUS STAHL

EMBOUT MÂLE EN ACIER

ADAPTADOR EN ACERO MACHO

PLUG EM AÇO COM ROSCA MACHO

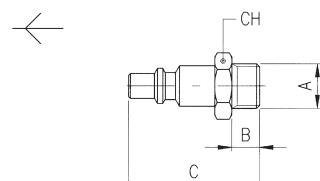

Code	A	B	C	CH	Pack.
251AC 00 51 03 ZI	1/4	8	38	17	10
251AC 00 51 04 ZI	3/8	9	39	19	10
251AC 00 51 05 ZI	1/2	10	40.5	24	10

Acciaio Indurito
 Hardened Steel
 Gehärtetem Stahl
 Acier Trempé
 Acero Curtido
 Aço Endurecido

252

INNESTO FEMMINA

FEMALE PLUG
 STECKER MIT INNENGEWINDE
 EMBOUT FEMELLE
 ADAPTADOR HEMBRA
 PLUG COM ROSCA FÊMEA

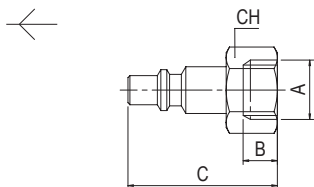

Code	A	B	C	CH	Pack.
00252 00 01 03 NB	1/4	11	38	17	10
00252 00 01 04 NB	3/8	11.5	38.5	19	10
00252 00 01 05 NB	1/2	14	41	24	10

252AC

INNESTO IN ACCIAIO FEMMINA

STEEL FEMALE PLUG
 STECKER MIT INNENGEWINDE AUS STAHL
 EMBOUT FEMELLE EN ACIER
 ADAPTADOR EN ACERO HEMBRA
 PLUG EM AÇO COM ROSCA FÊMEA

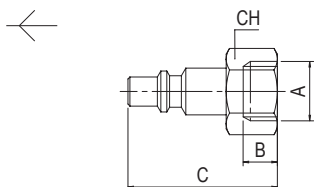

Code	A	B	C	CH	Pack.
252AC 00 51 03 ZI	1/4	11	38	17	10
252AC 00 51 04 ZI	3/8	11.5	38.5	19	10
252AC 00 51 05 ZI	1/2	14	41	24	10

Acciaio Indurito
 Hardened Steel
 Gehärtetem Stahl
 Acier Trempé
 Acero Curtido
 Aço Endurecido

253

INNESTO A CALZAMENTO CON MOLLA

COMPRESSION PLUG WITH SPRING
 STECKER MIT KNICKSCHUTZFEDER
 EMBOUT AVEC RESSORT DE PROTECTION
 ADAPTADOR TUBO CON MUELLE
 PLUG COM CONEXÃO PUSH-ON COM MOLA

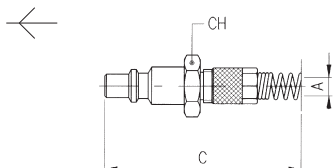

Code	A	C	CH	Pack.
00253 00 001	6/4	124.5	13	10
00253 00 002	8/6	130	13	10
00253 00 003	10/8	137.5	14	10
00253 00 004	12/10	143	16	10

Molla Acciaio Inox AISI 304 - EN 1.4301
 Stainless Steel Spring AISI 304 - EN 1.4301
 Edelstahlfeder AISI 304 - EN 1.4301
 Ressort Acier Inoxydable AISI 304 - EN 1.4301
 Muelle Acero Inoxidable AISI 304 - EN 1.4301
 Mola Aço Inoxidável AISI 304 - EN 1.4301

254

INNESTO A CALZAMENTO

COMPRESSION PLUG
 STECKER MIT ÜBERWURFVERSCHRAUBUNG
 EMBOUT À RACCORD À COIFFE
 ADAPTADOR TUBO
 PLUG COM CONEXÃO PUSH-ON

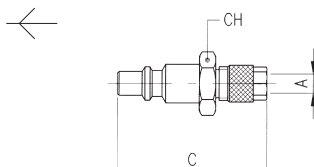

Code	A	C	CH	Pack.
00254 00 001	6/4	43.5	13	10
00254 00 002	8/6	43.5	13	10
00254 00 003	10/8	44.5	14	10
00254 00 004	12/10	46	16	10

255

INNESTO CON PORTAGOMMA A RESCA

BARBED PLUG
 STECKER MIT SCHLAUCHTÜLLE
 EMBOUT À DOUILLE ANNELÉE POUR TUBE
 ADAPTADOR ESPIGA
 PLUG COM ESPIGÃO PARA TUBO DE BORRACHA



Code	A	C	D	Pack.
00255 00 01 X4 NB	6	44.5	12	10
00255 00 01 X7 NB	8	44.5	12	10
00255 00 01 X9 NB	10	47.5	14	10
00255 00 01 Y1 NB	12	47.5	16	10

255AC

INNESTO IN ACCIAIO CON PORTAGOMMA A RESCA

STEEL BARBED PLUG
 STECKER MIT SCHLAUCHTÜLLE AUS STAHL
 EMBOUT À DOUILLE ANNELÉE POUR TUBE EN ACIER
 ADAPTADOR EN ACERO ESPIGA
 PLUG EM AÇOÙ COM ESPIGÃO PARA TUBO DE BORRACHA



Code	A	C	D	Pack.
255AC 00 51 X4 ZI	6	44.5	12	10
255AC 00 51 X7 ZI	8	44.5	12	10
255AC 00 51 X9 ZI	10	47.5	14	10
255AC 00 51 Y1 ZI	12	47.5	16	10

Acciaio Indurito
 Hardened Steel
 Gehärtetem Stahl
 Acier Trempé
 Acero Curtido
 Aço Endurecido

256

INNESTO CON PORTAGOMMA

PLUG FOR RUBBER HOSE
 STECKER FÜR GUMMISCHLAUCH
 EMBOUT POUR TUBE
 ADAPTADOR CON PORTAGOMA
 PLUG COM ESPIGÃO PARA TUBO DE BORRACHA

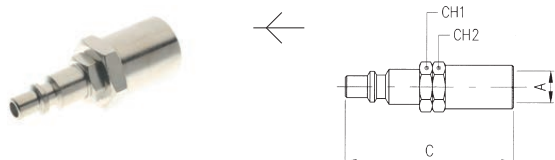

Code	A	C	CH1	CH2	Pack.
00256 00 001	14/6	60	15	17	10
00256 00 002	17/8	60	15	20	10
00256 00 003	19/10	60	15	22	10

257

INNESTO A BAIONETTA

BAYONET PLUG
 STECKER MIT BAJONETT-VERSCHLUSS
 EMBOUT À RACCORD À BAIONNETTE
 ADAPTADOR BAYONETA
 PLUG COM CONEXÃO TIPO BAIONETA

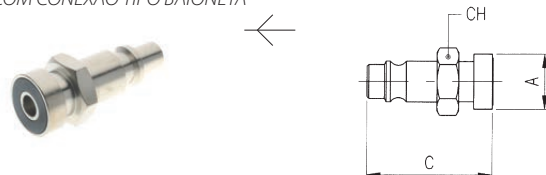

Code	A	C	CH	Pack.
00257 00 001	15	38.5	15	10

258

INNESTO A SCARICO PROGRESSIVO

PLUG WITH GRADUAL EXHAUST
 STECKER MIT PROGRESSIVER ENTLASTUNG
 EMBOUT À PASSAGE PROGRESSIF
 ADAPTADOR DE DESCARGA PROGRESIVA
 PLUG COM ESCAPE PROGRESSIVO

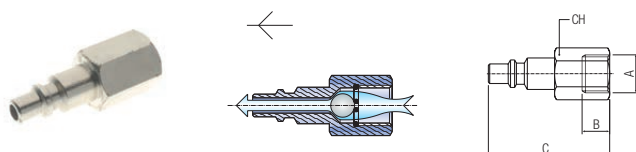

Code	A	B	C	CH	Pack.
00258 00 001	1/4	11	46.5	17	10