

SERIE B - CILINDRI CORSA BREVE



SHORT STROKE CYLINDERS
KURZHUBZYLINDER
VÉRINS À FAIBLE COURSE
CILINDROS CARRERA CORTA
CILINDROS DE CURSO REDUZIDO



CARATTERISTICHE TECNICHE
TECHNICAL CHARACTERISTICS
TECHNISCHE ANGABEN
CARACTÉRISTIQUES TECHNIQUES
CARACTERÍSTICAS TÉCNICAS
CARACTERÍSTICAS TÉCNICAS

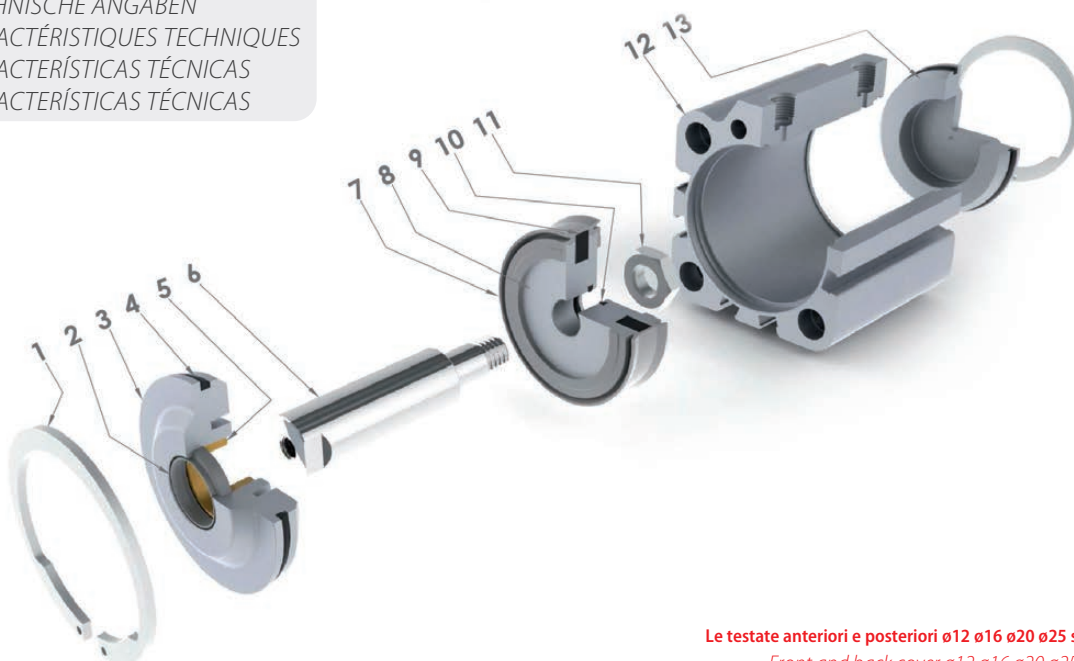

Le testate anteriori e posteriori ø12 ø16 ø20 ø25 sono in ottone giallo.

Front and back cover ø12 ø16 ø20 ø25 are made in brass.

Die zylinderköpfe und deckel ø12 ø16 ø20 ø25 sind aus messing.

Les flasques avant et arrière ø12 ø16 ø20 ø25 sont en laiton.

Las tapas anterior y posterior ø12 ø16 ø20 ø25 son en latón natural.

Os cabeçotes frontal e traseiro para os diâmetros de ø12 ø16 ø20 ø25 são feitos em latão.

Materiali e Componenti	IT	Component Parts and Materials	GB	Komponenten und Materialien	DE
1 Seeger in acciaio		1 Steel Seeger		1 Seegerring aus Stahl	
2 Guarnizione asta in poliuretano		2 Polyurethane Rod Seal		2 Kolbenstangendichtung aus Polyurethan	
3 Testata anteriore in alluminio anodizzato		3 Anodised aluminium Front cover		3 Zylinderdeckel Aluminium eloxiert	
4 Guarnizioni in NBR		4 NBR Seals		4 Dichtung aus NBR	
5 Bronzina in bronzo sinterizzato		5 Sintered bronze Bearing		5 Gleitlager Sinterbronze	
6 Asta pistone acciaio cromato (AISI 303 da 12 a 25) (C40 da 32 a 100)		6 Chrome steel Piston rod (AISI 303 from 12 to 25)(C40 from 32 to 100)		6 Kolbenstange Stahl verchromt (AISI 303 von 12 bis 25) (C40 von 32 bis 100)	
7 Guarnizione pistone in poliuretano		7 Polyurethane Piston Seal		7 Kolbendichtung aus Polyurethan	
8 Pistone in alluminio		8 Aluminium Piston		8 Kolben Aluminium	
9 Magnete in plastoferrite		9 Plastroferrite Magnet		9 Magnetring Plastroferrit	
10 O-Ring in NBR		10 O-Ring in NBR		10 O-Ring Dichtung aus NBR	
11 Dado pistone in acciaio zincato		11 Zinc-plated steel Piston Nut		11 Kolbenmutter Stahl verzinkt	
12 Camicia cilindro in alluminio anodizzato		12 Anodised aluminium Cylinder shape body		12 Zylinderrohr Aluminium eloxiert	
13 Testata posteriore in alluminio anodizzato		13 Anodised aluminium Back cover		13 Zylinderdeckel Aluminium eloxiert	
Matériaux et Composants	FR	Materiales y componentes	ES	Materiais e Componentes	PT
1 Circlips in acier		1 Seeger en acero		1 Anel de retenção tipo Seeger em Aço	
2 Joint de tige en polyuréthane		2 Junta vástago en poliuretano		2 Vedação da haste em poliuretano	
3 Flasque en aluminium anodisé		3 Tapa anterior en aluminio anodizado		3 Cabeçote frontal em alumínio anodizado	
4 Joint en NBR		4 Juntas en NBR		4 Vedações em NBR	
5 Palier en bronze fritté		5 Cojinete en bronce sinterizado		5 Bucha do cabeçote em bronze sinterizado	
6 Tige de piston en acier chromé (AISI 303 de 12 à 25)(C40 de 32 à 100)		6 Vástago pistón acero cromado (AISI 303 de 12 a 25) (C40 de 32 a 100)		6 Haste do cilindro em Aço Cromado (AISI 303 da 12 a 25) (C40 da 32 a 100)	
7 Joint de piston en polyuréthane		7 Junta pistón en poliuretano		7 Vedação do êmbolo em poliuretano	
8 Piston en aluminium		8 Pistón en aluminio		8 Êmbolo em alumínio	
9 Bague magnétique en plastoferrite		9 Magnete en plastoferrite		9 Imã em plastoferrite	
10 Joint torique en NBR		10 Junta tórica en NBR		10 O-ring em NBR	
11 Ecrou de piston en acier galvanisé		11 Tuerca pistón en acero zincado		11 Porca do êmbolo em Aço Zincado	
12 Corps en aluminium anodisé		12 Camisa cilindro en aluminio anodizado		12 Camisa do cilindro em alumínio anodizado	
13 Flasque en aluminium anodisé		13 Tapa posterior en aluminio anodizado		13 Cabeçote traseiro em alumínio anodizado	



Norma di Riferimento

Reference standard

Entspricht der Norm

Norme de référence

Normativa de referencia

Norma de referência

1907/2006

REACH ✓

2011/65/CE

RoHS ✓

SILICON
FREE

II 2GD Ex h IIC T6

Ex



Pressioni

Pressures

Druckbereich

Pressions

Presiones

Pressões

1 bar (0.1 MPa)

10 bar (1 MPa)



Temperature

Temperatures

Temperatur

Températures

Temperaturas

Temperaturas

0 °C (-20 °C con aria secca)

(-20 °C with dry air)

(-20 °C mit trockener Luft)

(-20 °C avec air sec)

(-20 °C con aire seco)

(-20 °C com ar seco)

+ 80 °C



Fluidi compatibili

Aria compressa filtrata lubrificata e non lubrificata.

Fluids

Filtered and lubricated compressed air as well as non lubricated air.

Geignete Medien

Gefilterte druckluft, auch für mit öl versetzte druckluft geeignet.

Fluides compatibles

Air comprimé filtré, lubrifié ou non lubrifié.

Fluidos compatibles

Aire comprimido filtrado lubricado y no lubricado.

Fluidos compatíveis

Ar comprimido filtrado e lubrificado ou não lubrificado.



Funzionamento

Semplice e Doppio effetto magnetico. Stelo singolo e passante magnetico. Antirotazione magnetico.

Functioning

Single and Double-acting magnetic. Single or through piston rod magnetic. Antirotation magnetic.

Funktion

Einfach- und doppelwirkend Magnetisch. Einseitig oder durchgehende Kolbenstange. Verdrehgesichert.

Exécutions

Simple ou double effet Magnétique. Tige de piston simple ou traversante. Antirotation Magnétique.

Funcionamiento

Simple y doble efecto magnético. Vástago simple o pasante magnético. Antirotación magnético.

Funcionamento

Simples e Dupla Ação Magnético. Haste Simples ou Passante Magnético. Anti-Giro Magnético.



Alesaggi

Bores

Durchmesser

Diamètres

Diámetros

Diâmetros

from 12 to 100 mm



from 20 to 25 mm

UNITOP

from 32 to 100 mm

ISO
15552



Corse Standard

Standard Strokes

Standardhub

Courses standards

Carreras Standard

Cursos Padrão

from 5 to 100 mm



Sensori consigliati

Sensors recommended

Empfohlene Sensoren

Capteurs recommandés

Sensores recomendados

Sensores aconselhados

DT

Forze della molla - Spring traction forces - Federkraft - Force du ressort - Fuerza del muelle - Força da mola.

Cilindro Cylinder Zylinder Vérins Cilindro Cilindro	Carico molla Load spring Federbelastung Charge du ressort Carga Muelle Força da Mola	Corsa Stroke Hub Course Carrera Curso							
		5	10	15	20	25	30	40	50
Ø		Forza sviluppata Output force Zylinderkraft Force du vérin Fuerza desarrollada Força desenvolvida N							
12	R	7,5	6,8	6	5,2	4,5			
	C	8	8	8	8	8			
16	R	12,3	10,8	9,5	7,8	6,5			
	C	13,3	13,3	13,3	13,3	13,3			
20	R	15,7	14	12,2	10,4	8,7			
	C	17,4	17,4	17,4	17,4	17,4			
25	R	19,5	18,5	17,3	16	15			
	C	22	22	22	22	22			
32	R	13,1	23,6	34	39,3	44,5	49,8	55	60,3
	C	65,5	65,5	65,5	65,5	65,5	65,5	65,5	65,5
40	R	44,7	42,2	39,6	37	34,4	31,8	26,7	21,6
	C	47,3	47,3	47,3	47,3	47,3	47,3	47,3	47,3
50	R	32,6	31	29,6	28,1	26,6	25,1	22,2	19,2
	C	34	34	34	34	34	34	34	34
63	R	62,3	59,8	57,2	54,7	52,2	49,7	44,6	39,6
	C	64,8	64,8	64,8	64,8	64,8	64,8	64,8	64,8
80	R	90,7	87	84,4	81,3	78	75	68,7	62,5
	C	93,8	93,8	93,8	93,8	93,8	93,8	93,8	93,8
100	R	156	150	145	140	134	129	118	107
	C	161	161	161	161	161	161	161	161

R : Carico Molla a Riposo
Load of spring at rest
Feder in Ruhestellung
Ressort en position neutre
Carga Muelle en Reposo
Força da Mola em Repouso

C : Carico Molla Compressa
Load of compressed spring
Feder komprimiert
Ressort comprimé
Carga Muelle Comprimido
Força da Mola Comprimida

Consumi cilindro - Cylinder air consumption - Zylinder Luftverbrauch - Consommation d'air des vérins - Consumo cilindro - Consumo de ar do cilindro.

Cilindro Cylinder Zylinder Vérins Cilindro Cilindro	Stelo Rod Stange Tige Vástago Haste	Superficie utile Working Surface Arbeitsfläche Surface de travail Superficie útil Superficie útil	Pressione di lavoro Operating pressure Betriebsdruck Pression de service Presión de trabajo Pressão de operação									
			bar									
Ø	Ø	mm ²	1	2	3	4	5	6	7	8	9	10
Consumo aria per ogni 10 mm di corsa Air consumption for each 10 mm of stroke Luftverbrauch pro 10 mm Hub Consommation d'air par 10 mm de course Consumo aire para cada 10 mm de carrera Consumo de ar para cada 10 mm de curso NI												
12	6	S = 113	0,002	0,003	0,005	0,006	0,007	0,008	0,009	0,010	0,011	0,012
		T = 85	0,002	0,003	0,003	0,004	0,005	0,006	0,007	0,008	0,009	0,009
16	8	S = 200	0,004	0,006	0,008	0,010	0,012	0,014	0,016	0,018	0,020	0,022
		T = 150	0,003	0,005	0,006	0,008	0,009	0,011	0,012	0,014	0,015	0,017
20	10	S = 314	0,006	0,009	0,013	0,016	0,019	0,022	0,025	0,028	0,031	0,035
		T = 235	0,005	0,007	0,009	0,012	0,014	0,016	0,019	0,021	0,024	0,026
25	10	S = 490	0,010	0,015	0,020	0,025	0,029	0,034	0,039	0,044	0,049	0,054
		T = 412	0,008	0,012	0,016	0,021	0,025	0,029	0,033	0,037	0,041	0,045
32	12	S = 804	0,016	0,024	0,032	0,040	0,048	0,056	0,064	0,072	0,080	0,088
		T = 691	0,014	0,021	0,028	0,035	0,041	0,048	0,055	0,062	0,069	0,076
40	12	S = 1257	0,025	0,038	0,050	0,063	0,075	0,088	0,101	0,113	0,126	0,138
		T = 1144	0,023	0,034	0,046	0,057	0,069	0,080	0,092	0,103	0,114	0,126
50	16	S = 1963	0,039	0,059	0,079	0,098	0,118	0,137	0,157	0,177	0,196	0,216
		T = 1762	0,035	0,053	0,070	0,088	0,106	0,123	0,141	0,159	0,176	0,194
63	16	S = 3117	0,062	0,094	0,125	0,156	0,187	0,218	0,249	0,281	0,312	0,343
		T = 2916	0,058	0,087	0,117	0,146	0,175	0,204	0,233	0,262	0,292	0,321
80	20	S = 5027	0,101	0,151	0,201	0,251	0,302	0,352	0,402	0,452	0,503	0,553
		T = 4712	0,094	0,141	0,188	0,236	0,283	0,330	0,377	0,424	0,471	0,518
100	25	S = 7854	0,157	0,236	0,314	0,393	0,471	0,550	0,628	0,707	0,785	0,864
		T = 7363	0,147	0,221	0,295	0,368	0,442	0,515	0,589	0,663	0,736	0,810

S : Spinta
Thrust
Schub
Poussée
Empuje
Avanço

T : Trazione
Traction
Zugkraft
Tracción
Recuo



Tabella dei codici di ordinazione

Ordering codes

Bestellschlüssel

Code de commande

Tabla de codificación para pedidos

Tabela de codificação para compra

SERIE	Versione Version Ausführung Version Version Versão	Ø mm	Corsa Stroke Hub Course Carrera Curso mm
-------	---	---------	--

B B



0 1 2

0 0 2 5

▲ BB Semplice Effetto Magnetico

Single-Acting Magnetic
Einfachwirkend Magnetisch
Simple Effet Magnétique
Simple Efecto Magnético
Simples Ação Magnético

= Standard Stelo femmina

Standard female rod
Standard: Kolbenstange mit IG
Standard: tige avec taraudage
Standard Vástago hembra
Standard haste fêmea

012

016

020

025

032

040

050

063

080

100

0005

0010

0015

0020

0025

0030

0040

0050

0075

0100

▲ BD Semplice Effetto Magnetico

Molla in spinta
Single-Acting Magnetic - Spring Thrust
Einfachwirkend Magnetisch
Kolben Ausgefahren
Simple Effet Magnétique - Tige Sortie
Simple Efecto Magnético - Muelle en Empuje
Simples Ação Magnético - Avanço Mola

M = Stelo Maschio (NO BFA)

Male rod (NO BFA)
Aussengewinde (NO BFA)
Filetage mâle (NO BFA)
Vástago Macho (NO BFA)
Haste macho (menos modelo BFA)

● BF Doppio Effetto Magnetico

Double Acting Magnetic
Doppeltwirkend Magnetisch
Double Effet Magnétique
Doble efecto magnético
Dupla Ação Magnético

● BJ Doppio Effetto Stelo Passante Magnetico

Double Acting Magnetic With Double Rod End
Doppeltwirkend Durchgehender Kolben Magnetisch
Double Effet Tige Traversante Magnétique
Doble Efecto Vástago pasante Magnético
Dupla Ação Haste Passante Magnético

● BFA Doppio Effetto Magnetico Antirrotazione

Double Acting Magnetic Antirotation
Doppeltwirkend Magnetisch Verdrehsichert
Double Effet Magnétique Antirrotation
Doble Efecto Magnético Antirrotación
Dupla Ação Magnético Anti-Giro

A richiesta corse intermedie o superiori.

Intermediate or higher strokes are available upon request.

Auf Anfrage Zwischenhübe.

Autres courses sur demande.

Bajo demanda carreras intermedias o superiores.

Cursos intermedíarios ou superiores sob encomenda.

Ø mm	Corse - Strokes - Hub - Courses - Carreras - Cursos mm										
	5	10	15	20	25	30	40	50	75	100	
12	●▲	●▲	●▲	●▲	●▲	●	●				
16	●▲	●▲	●▲	●▲	●▲	●	●				
20	●▲	●▲	●▲	●▲	●▲	●	●	●			
25	●▲	●▲	●▲	●▲	●▲	●	●	●			
32	●▲	●▲	●▲	●▲	●▲	●▲	●▲	●▲	●	●	
40	●▲	●▲	●▲	●▲	●▲	●▲	●▲	●▲	●	●	
50	●▲	●▲	●▲	●▲	●▲	●▲	●▲	●▲	●	●	
63	●▲	●▲	●▲	●▲	●▲	●▲	●▲	●▲	●	●	
80	●▲	●▲	●▲	●▲	●▲	●▲	●▲	●▲	●	●	
100	●▲	●▲	●▲	●▲	●▲	●▲	●▲	●▲	●	●	

BB

SEMPLICE EFFETTO MAGNETICO

SINGLE-ACTING MAGNETIC
 EINFACHWIRKEND MAGNETISCH
 SIMPLE EFFET MAGNÉTIQUE
 SIMPLE EFECTO MAGNÉTICO
 SIMPLAS AÇÃO MAGNÉTICO

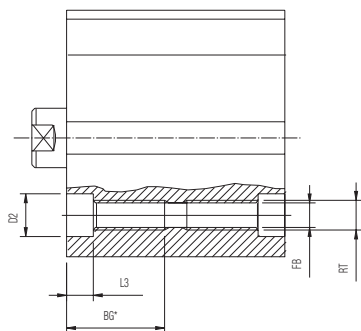
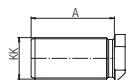
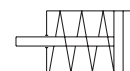

Ø 12-16-20-25

Ø 32-40-50-63-80-100

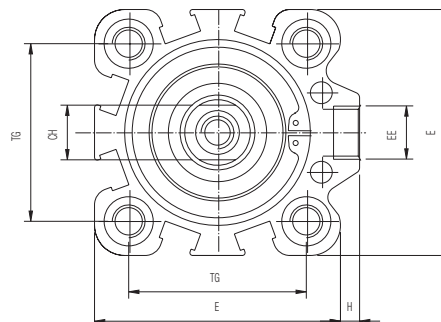
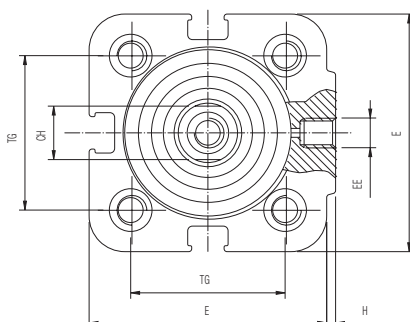
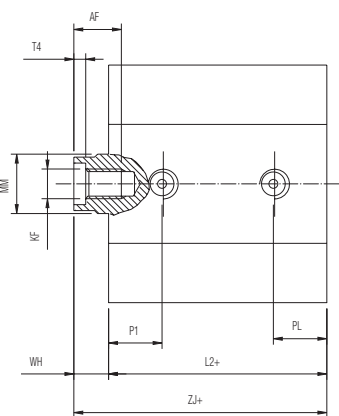

+ = Aggiungere la corsa

Add Stroke
 Hinzufügen des Hubes
 Additionner la course
 Añadir la carrera
 Adicionar o curso

*** = Per corsa corta filetto passante**

Through threads only on small strokes
 Durchgehendes gewinde nur beim kurzzyylinder
 Filetages traversants seulement pour les faibles courses
 Para carrera corta rosca pasante
 Para cursos reducidos rosca pasante

Ø	KK	A	AF	RT	BG*	ØD2	E	EE	ØFB	H	KF	L2+	L3	ØMM	P1	PL	T4	TG	WH	ZJ+	CH
12	M6	16	6	M4	12.5	5.5	29	M5	3.3	1	M3	28	3.5	6	7.5	7.5	1.5	18	6	34	5
16	M8	20	8	M4	14.5	5.5	29	M5	3.3	1	M4	30.5	3.5	8	8.5	8.5	2	18	6	36.5	7
20	M10X1,25	22	8	M5	16.5	7.2	36	M5	4.2	1.5	M5	31.5	4.5	10	9	9	2	22	6	37.5	9
25	M10X1,25	22	8	M5	16.5	7.2	40	M5	4.2	1.5	M5	31.5	4.5	10	9	9	2	26	6	37.5	9
32	M10X1,25	22	10	M6	21.7	8.5	45	G1/8	5	3.5	M6	32	5.7	12	10	10	2.8	32.5	7	39	10
40	M10X1,25	22	10	M6	21.7	8.5	52	G1/8	5	5	M6	38.5	5.7	12	11	11	2.8	38	7.2	45.7	10
50	M12X1,25	24	12	M8	22.8	10	63.5	G1/8	6.8	7	M8	39	6.8	16	11	11	3.5	46.5	8.5	47.5	13
63	M12X1,25	24	12	M8	22.8	10	77	G1/8	6.8	7	M8	46	6.8	16	11.5	11.5	3.5	56.5	8	54	13
80	M16X1,5	32	16	M10	25	13	92	G1/8	8.5	10	M10	54	9	20	14	14	4.5	72	11	65	17
100	M20X1,5	40	20	M10	25	13	113	G1/4	8.5	13	M12	65	9	25	17.5	17.5	6	89	12	77	22

BD

SEMPLICE EFFETTO MAGNETICO - MOLLA IN SPINTA

SINGLE-ACTING MAGNETIC - SPRING THRUST
 EINFACHWIRKEND MAGNETISCH KOLBEN AUSGEFAHREN
 SIMPLE EFFET MAGNÉTIQUE - TIGE SORTIE
 SIMPLE EFECTO MAGNÉTICO - MUELLE EN EMPUJE
 SIMPLAS AÇÃO MAGNÉTICO - AVANÇO MOLA

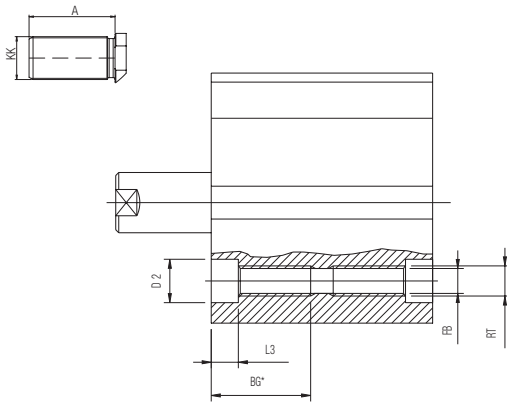

Ø 12-16-20-25

Ø 32-40-50-63-80-100

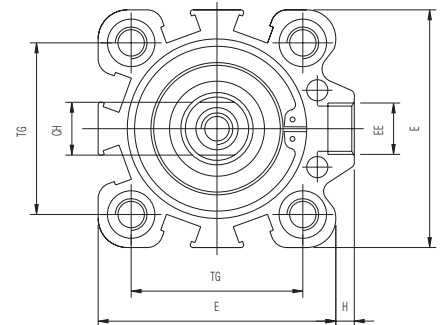
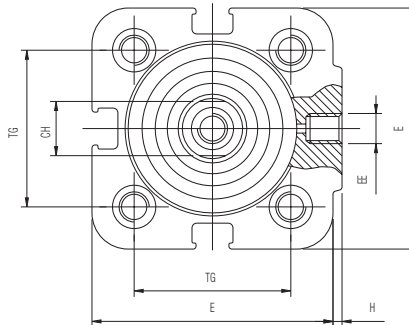
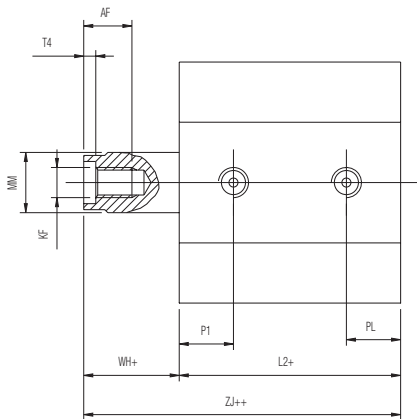

+ = Aggiungere la corsa
 Add Stroke
 Hinzufügen des Hubes
 Additionner la course
 Añadir la carrera
 Adicionar o curso

++ = Aggiungere 2 volte la corsa
 Double stroke dimension and add it
 Hinzufügen des doppelten Hubes
 Additionner 2 fois la course
 Añadir 2 veces la carrera
 Adicionar 2 veces o curso

*** = Per corsa corta filetto passante**
 Through threads only on small strokes
 Durchgehendes gewinde nur beim kurzzyylinder
 Filetages traversants seulement pour les faibles courses
 Para carrera corta rosca pasante
 Para cursos reducidos rosca passante

Ø	KK	A	AF	RT	BG*	ØD2	E	EE	ØFB	H	KF	L2+	L3	ØMM	P1	PL	T4	TG	WH+	ZJ++	CH
12	M6	16	6	M4	12.5	5.5	29	M5	3.3	1	M3	28	3.5	6	7.5	7.5	1.5	18	6	34	5
16	M8	20	8	M4	14.5	5.5	29	M5	3.3	1	M4	30.5	3.5	8	8.5	8.5	2	18	6	36.5	7
20	M10X1,25	22	8	M5	16.5	7.2	36	M5	4.2	1.5	M5	31.5	4.5	10	9	9	2	22	6	37.5	9
25	M10X1,25	22	8	M5	16.5	7.2	40	M5	4.2	1.5	M5	31.5	4.5	10	9	9	2	26	6	37.5	9
32	M10X1,25	22	10	M6	21.7	8.5	45	G1/8	5	3.5	M6	32	5.7	12	10	10	2.8	32.5	7	39	10
40	M10X1,25	22	10	M6	21.7	8.5	52	G1/8	5	5	M6	38.5	5.7	12	11	11	2.8	38	7.2	45.7	10
50	M12X1,25	24	12	M8	22.8	10	63.5	G1/8	6.8	7	M8	39	6.8	16	11	11	3.5	46.5	8.5	47.5	13
63	M12X1,25	24	12	M8	22.8	10	77	G1/8	6.8	7	M8	46	6.8	16	11.5	11.5	3.5	56.5	8	54	13
80	M16X1,5	32	16	M10	25	13	92	G1/8	8.5	10	M10	54	9	20	14	14	4.5	72	11	65	17
100	M20X1,5	40	20	M10	25	13	113	G1/4	8.5	13	M12	65	9	25	17.5	17.5	6	89	12	77	22

BF

DOPPIO EFFETTO MAGNETICO

DOUBLE ACTING MAGNETIC
 DOPPELTWIRKEND MAGNETISCH
 DOUBLE EFFET MAGNÉTIQUE
 DOBLE EFECTO MAGNÉTICO
 DUPLA AÇÃO MAGNÉTICO

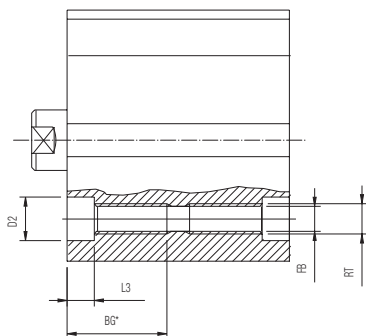
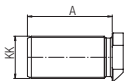
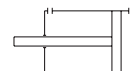

Ø 12-16-20-25

Ø 32-40-50-63-80-100

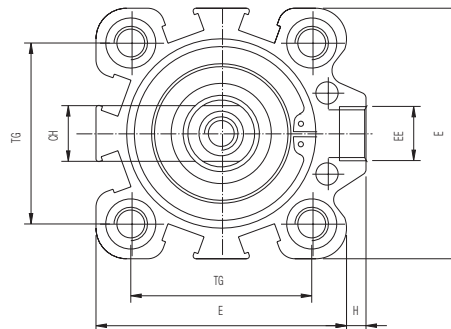
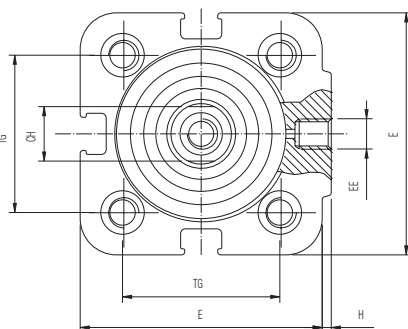
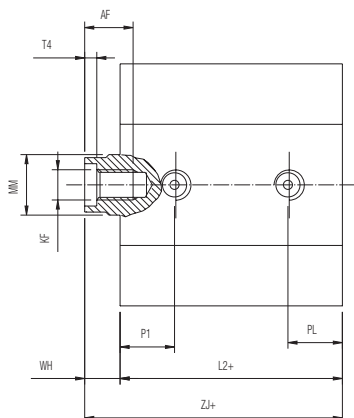

+ = Aggiungere la corsa
 Add Stroke
 Hinzufügen des Hubes
 Additionner la course
 Añadir la carrera
 Adicionar o curso

*** = Per corsa corta filetto passante**
 Through threads only on small strokes
 Durchgehendes gewinde nur beim kurzzyylinder
 Filetages traversants seulement pour les faibles courses
 Para carrera corta rosca pasante
 Para cursos reducidos rosca pasante

Ø	KK	A	AF	RT	BG*	ØD2	E	EE	ØFB	H	KF	L2+	L3	ØMM	P1	PL	T4	TG	WH	ZJ+	CH
12	M6	16	6	M4	12.5	5.5	29	M5	3.3	1	M3	28	3.5	6	7.5	7.5	1.5	18	6	34	5
16	M8	20	8	M4	14.5	5.5	29	M5	3.3	1	M4	30.5	3.5	8	8.5	8.5	2	18	6	36.5	7
20	M10X1,25	22	8	M5	16.5	7.2	36	M5	4.2	1.5	M5	31.5	4.5	10	9	9	2	22	6	37.5	9
25	M10X1,25	22	8	M5	16.5	7.2	40	M5	4.2	1.5	M5	31.5	4.5	10	9	9	2	26	6	37.5	9
32	M10X1,25	22	10	M6	21.7	8.5	45	G1/8	5	3.5	M6	32	5.7	12	10	10	2.8	32.5	7	39	10
40	M10X1,25	22	10	M6	21.7	8.5	52	G1/8	5	5	M6	38.5	5.7	12	11	11	2.8	38	7.2	45.7	10
50	M12X1,25	24	12	M8	22.8	10	63.5	G1/8	6.8	7	M8	39	6.8	16	11	11	3.5	46.5	8.5	47.5	13
63	M12X1,25	24	12	M8	22.8	10	77	G1/8	6.8	7	M8	46	6.8	16	11.5	11.5	3.5	56.5	8	54	13
80	M16X1,5	32	16	M10	25	13	92	G1/8	8.5	10	M10	54	9	20	14	14	4.5	72	11	65	17
100	M20X1,5	40	20	M10	25	13	113	G1/4	8.5	13	M12	65	9	25	17.5	17.5	6	89	12	77	22

BJ

DOPPIO EFFETTO STELO PASSANTE MAGNETICO

DOUBLE ACTING MAGNETIC WITH DOUBLE ROD END
 DOPPELTWIRKEND DURCHGEHENDER KOLBEN MAGNETISCH
 DOUBLE EFFET TIGE TRAVERSANTE MAGNÉTIQUE
 DOBLE EFECTO VÁSTAGO PASANTE MAGNÉTICO
 DUPLA AÇÃO HASTE PASSANTE MAGNÉTICO

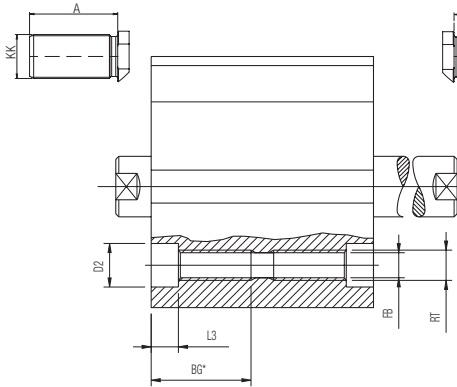
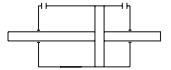

Ø 12-16-20-25

Ø 32-40-50-63-80-100

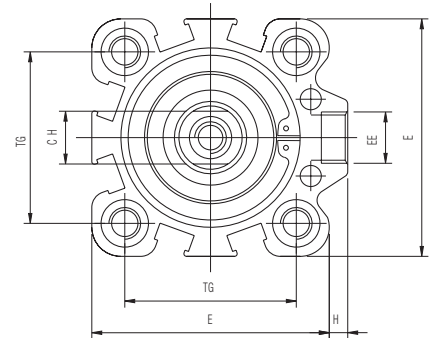
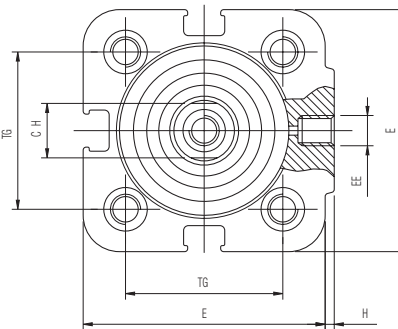
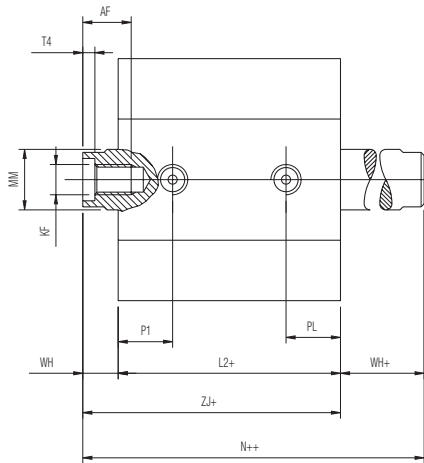

+ = Aggiungere la corsa
 Add Stroke
 Hinzufügen des Hubes
 Additionner la course
 Añadir la carrera
 Adicionar o curso

++ = Aggiungere 2 volte la corsa
 Double stroke dimension and add it
 Hinzufügen des doppelten Hubes
 Additionner 2 fois la course
 Añadir 2 veces la carrera
 Adicionar 2 veces o curso

*** = Per corsa corta filetto passante**
 Through threads only on small strokes
 Durchgehendes gewinde nur beim kurzzyylinder
 Filetages traversants seulement pour les faibles courses
 Para carrera corta rosca pasante
 Para cursos reducidos rosca passante

Ø	KK	A	AF	RT	BG*	ØD2	E	EE	ØFB	H	KF	CH	L2	L3	ØMM	P1	PL	T4	TG	N++	WH/WH+	ZJ+
12	M6	16	6	M4	12.5	5.5	29	M5	3.3	1	M3	5	28	3.5	6	7.5	7.5	1.5	18	40	6	34
16	M8	20	8	M4	14.5	5.5	29	M5	3.3	1	M4	7	30.5	3.5	8	8.5	8.5	2	18	42.5	6	36.5
20	M10X1,25	22	8	M5	16.5	7.2	36	M5	4.2	1.5	M5	9	31.5	4.5	10	9	9	2	22	43.5	6	37.5
25	M10X1,25	22	8	M5	16.5	7.2	40	M5	4.2	1.5	M5	9	31.5	4.5	10	9	9	2	26	43.5	6	37.5
32	M10X1,25	22	10	M6	21.7	8.5	45	G1/8	5	3.5	M6	10	32	5.7	12	10	10	2.8	32.5	46	7	39
40	M10X1,25	22	10	M6	21.7	8.5	52	G1/8	5	5	M6	10	38.5	5.7	12	11	11	2.8	38	53	7.2	45.7
50	M12X1,25	24	12	M8	22.8	10	63.5	G1/8	6.8	7	M8	13	39	6.8	16	11	11	3.5	46.5	56	8.5	47.5
63	M12X1,25	24	12	M8	22.8	10	77	G1/8	6.8	7	M8	13	46	6.8	16	11.5	11.5	3.5	56.5	62	8	54
80	M16X1,5	32	16	M10	25	13	92	G1/8	8.5	10	M10	17	54	9	20	14	14	4.5	72	76	11	65
100	M20X1,5	40	20	M10	25	13	113	G1/4	8.5	13	M12	22	65	9	25	17.5	17.5	6	89	89	12	77

BFA

DOPPIO EFFETTO MAGNETICO ANTIROTAZIONE

DOUBLE ACTING MAGNETIC ANTIROTATION

DOPPELTWIRKEND MAGNETISCH VERDREHGESICHERT

DOUBLE EFFET MAGNÉTIQUE ANTIROTATION

DOBLE EFECTO MAGNÉTICO ANTIROTACIÓN

DUPLA AÇÃO MAGNÉTICO ANTI-GIRO

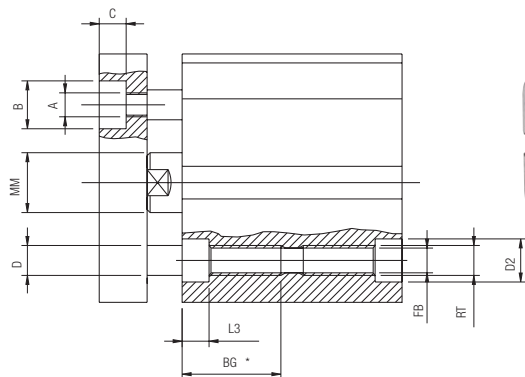
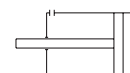

Ø 12-16-20-25

Ø 32-40-50-63-80-100

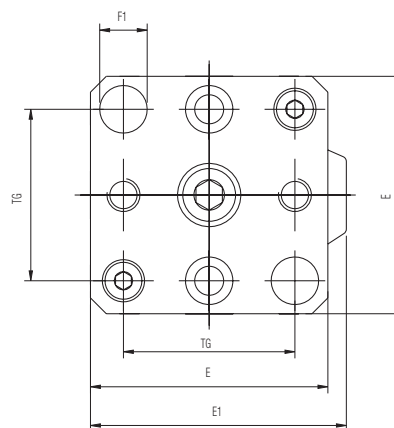
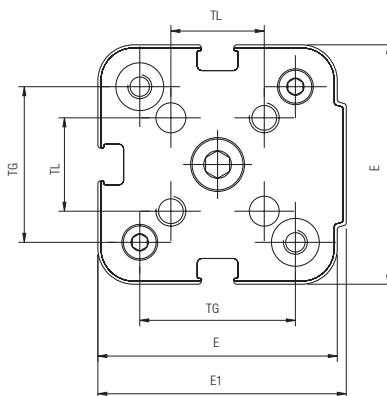
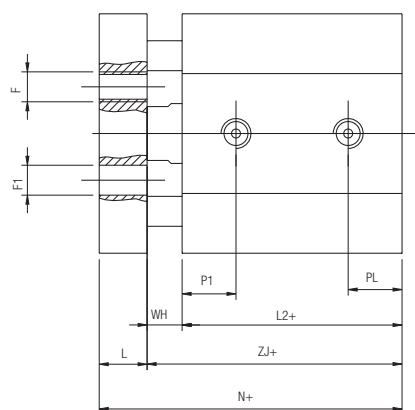

+ = Aggiungere la corsa

Add Stroke

Hinzufügen des Hubes

Additionner la course

Añadir la carrera

Adicionar o curso

*** = Per corsa corta filetto passante**

Through threads only on small strokes

Durchgehendes gewinde nur beim kurzzyylinder

Filetages traversants seulement pour les faibles courses

Para carrera corta rosca pasante

Para cursos reducidos rosca pasante

Ø	A	ØB	C	ØD	E	E1	F	ØF1	ØFB	RT	BG*	ØD2	L	L2+	L3	ØMM	P1	PL	TG	TL	WH	ZJ+	N+
12	M3	6	3.5	4	28.2	30	M3	3	3.5	M4	12.5	5.5	5	28	3.5	6	7.5	7.5	18	9.9	6	34	39
16	M3	6	3.5	4	28.2	30	M3	3	3.5	M4	14.5	5.5	5	30.5	3.5	8	8.5	8.5	18	9.9	6	36.5	41.5
20	M3	6	3.5	6	35	37.5	M4	4	4.2	M5	16.5	7	8	31.5	4.5	10	9	9	22	12	6	37.5	45.5
25	M4	8	4.5	6	39	41.5	M5	5	4.2	M5	16.5	7	8	31.5	4.5	10	9	9	26	15.6	6	37.5	45.5
32	4.5	8	4.5	6	45	48.5	M5	9	5	M6	21.7	8.5	10	32	5.7	12	10	10	32.5	-	7	39	48
40	4.5	8	4.5	6	52	57	M5	9	5	M6	21.7	8.5	10	38.5	5.7	12	11	11	38	-	7.2	45.7	55.5
50	5.5	9	5.5	8	63.5	70.5	M6	10	6.8	M8	22.8	10	12	39	6.8	16	11	11	46.5	-	8.5	47.5	59
63	5.5	9	5.5	8	75	84	M6	14	6.8	M8	22.8	10	12	46	6.8	16	11.5	11.5	56.5	-	8	54	66
80	8.5	14	9	12	90	102	M8	14	8.5	M10	25	13	14	54	9	20	14	14	72	-	11	65	79
100	8.5	14	9	12	110	126	M8	17	8.5	M10	25	13	14	65	9	25	17.5	17.5	89	-	12	77	91

QFL

FLANGIA

FLANGE
FLANSCH
BRIDE
BRIDA
FLANGE

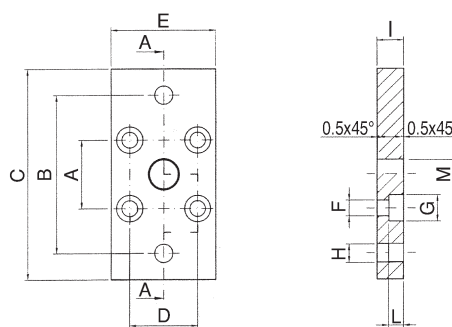

Code	Ø	A	B	C	D	E	F	G	H	I	L	M
QFL 012	12 - 16	18	43	55	18	29	4.5	9	5.5	10	5.4	10
QFL 020	20	22	55	70	22	36	5.5	10	6.6	10	5.4	12
QFL 025	25	26	60	76	26	40	5.5	10	6.6	10	5.4	12

MATERIALE: Acciaio - MATERIAL: Steel - MATERIAL: Stahl - MATÉRIEL: Acier - MATERIAL: Acero - MATERIAL: Aço

VFL

FLANGIA

FLANGE
FLANSCH
BRIDE
BRIDA
FLANGE

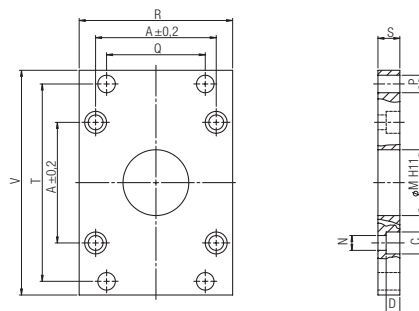

Code ●	Code ■	Ø	Ø M	P	S	D	C	N	A	Q	R	T	V
VFL 032	VFLI 032	32	30	7	10	5	10.5	6,5	32,5	32	45	64	80
VFL 040	VFLI 040	40	35	9	10	5	11	6,5	38	36	52	72	90
VFL 050	VFLI 050	50	40	9	12	5.5	15	8,5	46,5	45	65	90	110
VFL 063	VFLI 063	63	45	9	12	5.5	15	8,5	56,5	50	75	100	120
VFL 080	VFLI 080	80	45	12	16	8	18	10,5	72	63	95	126	150
VFL 100	VFLI 100	100	55	14	16	8	18	10,5	89	75	115	150	170

● MATERIALE: Acciaio - MATERIAL: Steel - MATERIAL: Stahl - MATÉRIEL: Acier - MATERIAL: Acero - MATERIAL: Aço
 ■ MATERIALE: Inox - MATERIAL: Inox - MATERIAL: Inox - MATÉRIEL: Inox - MATERIAL: Inox - MATERIAL: Inox
 VITE: DIN6912 - SCREW: DIN6912 - SCHRAUBE: DIN6912 - VIS: DIN6912 - TORNILLO: DIN6912 - PARAFUSO: DIN6912

QCP

PIEDINO BASSO

LOW-RISE PEDESTAL
FUSSBEFESTIGUNG
EQUERRE DE FIXATION
PATA
PÉS DE BAIXO PERFIL

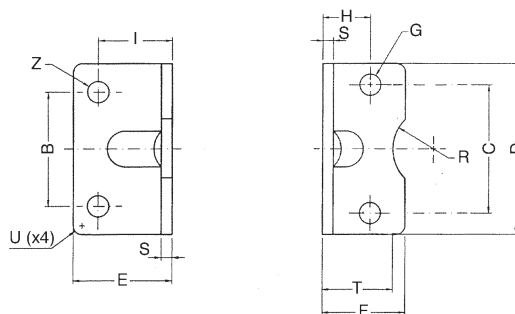

Code	Ø mm	C	B	D	E	F	G	H	I	S	T	R	U	Z
QCP 012	12 - 16	18	18	30	17.5	17.5	4.4	13	13	3	15	9	2	5.5
QCP 020	20	22	22	36	22	22	5.4	16	16	4	17	10	2	6.6
QCP 025	25	26	26	40	22	23	5.4	17	16	4	19	11	2	6.6

MATERIALE: Acciaio - MATERIAL: Steel - MATERIAL: Stahl - MATÉRIEL: Acier - MATERIAL: Acero - MATERIAL: Aço

VCP

PIEDINO BASSO

LOW-RISE PEDESTAL
FUSSBEFESTIGUNG
EQUERRE DE FIXATION
PATA
PÉS DE BAIXO PERFIL

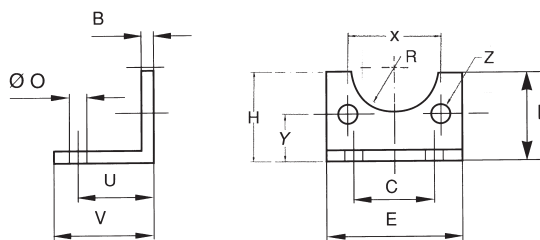

Code ●	Code ■	Ø	B	C	E	F	O	U	V	R	Z	X	Y	H
VCP 032	VCPI 032	32	4	32	45	30	7	24	35	15	7	32.5	15.75	32
VCP 040	VCPI 040	40	4	36	52	30	10	28	36	17.5	7	38	17	36
VCP 050	VCPI 050	50	5	45	65	36	10	32	47	20	9	46.5	21.75	45
VCP 063	VCPI 063	63	5	50	75	35	10	32	45	22.5	9	56.5	21.75	50
VCP 080	VCPI 080	80	6	63	95	47	12	41	55	22.5	11	72	27	63
VCP 100	VCPI 100	100	6	75	115	53	14.5	41	57	27.5	11	89	26.5	71

● **MATERIALE: Acciaio** - MATERIAL: Steel - MATERIAL: Stahl - MATÉRIEL: Acier - MATERIAL: Acero - MATERIAL: Aço

■ **MATERIALE: Inox** - MATERIAL: Inox - MATERIAL: Inox - MATÉRIEL: Inox - MATERIAL: Inox - MATERIAL: Inox

QCM

CERNIERA MASCHIO CON BOCCOLE AUTOLUBRIFICANTI

MALE HINGE WITH SELF-LUBRICATING BUSHES
GABELBEFESTIGUNG MIT SELBSTSCHMIERENDER LAGERBUCHSE
TENON AVEC COUSSINET AUTOLUBRIFIANT
CHARNELA MACHO CON COJINETES AUTOLUBRICANTES
FIXAÇÃO OSCILANTE TRASEIRA MACHO AUTO-LUBRIFICANTE

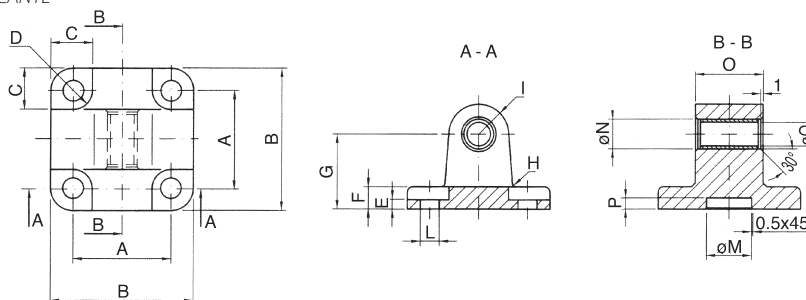

Code	Ø	A	B	C	D	E	F	G	H	I	L	M	N	O	P	Q
QCM 012	12 - 16	18	27	10	4.5	2.6	6	16	2	6	4.5	10	8	12	3	6
QCM 020	20	22	34	11	5	2.6	6	20	2	8	5.5	12	10	16	3	8
QCM 025	25	26	38	11	5	2.6	6	20	2	8	5.5	12	10	16	3	8

MATERIALE: Alluminio - MATERIAL: Aluminium - MATERIAL: Aluminium - MATÉRIEL: Aluminium - MATERIAL: Aluminio - MATERIAL: Alumínio

VCM

CERNIERA MASCHIO

MALE CLEVIS
SCHWENKBEFESTIGUNG
TENON À ROTULE
CHARNELA MACHO
FIXAÇÃO OSCILANTE TRASEIRA MACHO

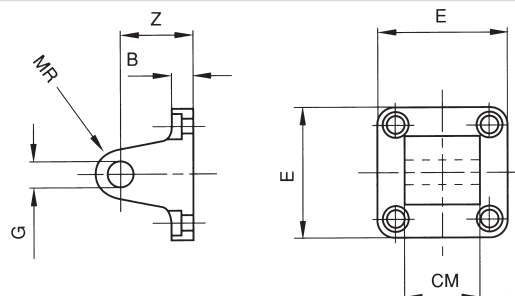

Code ●	Code ■	Code ◆	Ø	B	E	G	Z	CM	MR
VCM 032	VCM1 032	VCMZ 032 NE	32	9	45	10	22	26	10
VCM 040	VCM1 040	VCMZ 040 NE	40	9	52	12	25	28	12
VCM 050	VCM1 050	VCMZ 050 NE	50	11	65	12	27	32	12
VCM 063	VCM1 063	VCMZ 063 NE	63	11	75	16	32	40	16
VCM 080	VCM1 080	VCMZ 080 NE	80	14	95	16	36	50	16
VCM 100	VCM1 100	VCMZ 100 NE	100	14	115	20	41	60	20

● **MATERIALE: Alluminio** - MATERIAL: Aluminium - MATERIAL: Aluminium - MATÉRIEL: Aluminium - MATERIAL: Aluminio - MATERIAL: Alumínio

Con boccole autolubrificanti - With self-lubricating bushes - Mit selbstschmierender lagerbuchse - Avec coussinet autolubrifiant - Con cojinetes autolubricantes - Auto-lubrificante

■ **MATERIALE: Inox** - MATERIAL: Inox - MATERIAL: Inox - MATÉRIEL: Inox - MATERIAL: Inox - MATERIAL: Inox

◆ **MATERIALE: Ferro** - MATERIAL: Iron - MATERIAL: Eisen - MATÉRIEL: Fer - MATERIAL: Hierro - MATERIAL: Ferro

VCF

CERNIERA FEMMINA
 FEMALE CLEVIS BRACKET
 SCHWENKGABELBEFESTIGUNG
 CHAPE DE FIXATION
 HARNELA HEMBRA
 FIXAÇÃO OSCILANTE TRASEIRA FÊMEA

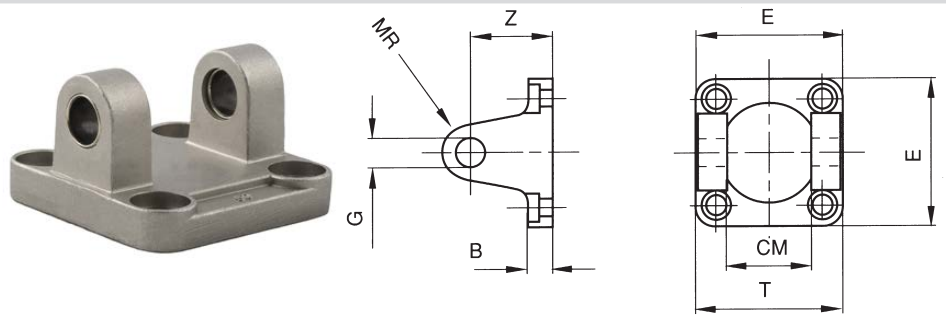

Code ●	Code ■	∅	B	E	G	T	Z	CM	MR
VCF 032	VCFI 032	32	9	45	10	45	22	26	10
VCF 040	VCFI 040	40	9	52	12	52	25	28	12
VCF 050	VCFI 050	50	11	65	12	60	27	32	12
VCF 063	VCFI 063	63	11	75	16	70	32	40	16
VCF 080	VCFI 080	80	14	95	16	90	36	50	16
VCF 100	VCFI 100	100	14	115	20	110	41	60	20

● **MATERIALE: Alluminio** - MATERIAL: Aluminium - MATERIAL: Aluminium - MATÉRIEL: Aluminium - MATERIAL: Aluminio - MATERIAL: Alumínio
 Con boccole autolubrificanti - With self-lubricating bushes - Mit selbstschmierender lagerbuchse - Avec coussinet autolubifiant - Con cojinetes autolubricantes - Auto-lubrificante
 ■ **MATERIALE: Inox** - MATERIAL: Inox - MATERIAL: Inox - MATÉRIEL: Inox - MATERIAL: Inox - MATERIAL: Inox

VAS

ARTICOLAZIONE A SQUADRA
 SQUARE JOINT
 LAGERBOCK
 TENON DE PALIER
 ARTICULACIÓN A ESCUADRA
 ARTICULAÇÃO QUADRADA

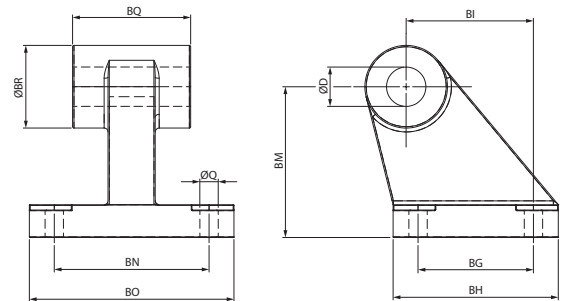

Code ●	Code ■	∅	Q	BG	BH	BI	BM	BN	BO	BQ	BR
VAS 032	VASI 032	32	6.6	18	31	21	32	38	51	26	20
VAS 040	VASI 040	40	6.6	22	35	24	36	41	54	28	22
VAS 050	VASI 050	50	9	30	45	33	45	50	65	32	26
VAS 063	VASI 063	63	9	35	50	37	50	52	67	40	30
VAS 080	VASI 080	80	11	40	60	47	63	66	86	50	30
VAS 100	VASI 100	100	11	50	70	55	71	76	96	60	38

● **MATERIALE: Alluminio** - MATERIAL: Aluminium - MATERIAL: Aluminium - MATÉRIEL: Aluminium - MATERIAL: Aluminio - MATERIAL: Alumínio
 ■ **MATERIALE: Inox** - MATERIAL: Inox - MATERIAL: Inox - MATÉRIEL: Inox - MATERIAL: Inox - MATERIAL: Inox

VPE

PERNO PER CERNIERA CON SEEGER
 PIN WITH SEEGER
 BOLZEN INKL. SEEGERRINGE
 AXE AVEC ANNEAUX CIRCLIPS
 PERNO PARA CHARNELA CON SEEGER
 PINO PARA FIXAÇÃO COM SEEGER

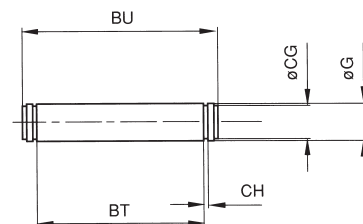

Code ●	Code ■	∅	G	BT	BU	CG	CH
VPE 032	VPEI 032	32	10	46	53	9.6	1.1
VPE 040	VPEI 040	40	12	53	60	11.5	1.1
VPE 050	VPEI 050	50	12	61	68	11.5	1.1
VPE 063	VPEI 063	63	16	71	78	15.2	1.1
VPE 080	VPEI 080	80	16	91	98	15.2	1.1
VPE 100	VPEI 100	100	20	111	118	19	1.3

● **MATERIALE: Acciaio** - MATERIAL: Steel - MATERIAL: Stahl - MATÉRIEL: Acier - MATERIAL: Acero - MATERIAL: Aço
 ■ **MATERIALE: Inox** - MATERIAL: Inox - MATERIAL: Inox - MATÉRIEL: Inox - MATERIAL: Inox - MATERIAL: Inox

TM

TESTA DI BIELLA MASCHIO

MALE ROD ENDS
 GELENKKOPF MIT AUßENGEWINDE
 OEILLETON À ROTULE AVEC FILETAGE MÂLE
 RÓTULA MACHO
 RÓTULA ESFÉRICA MACHO

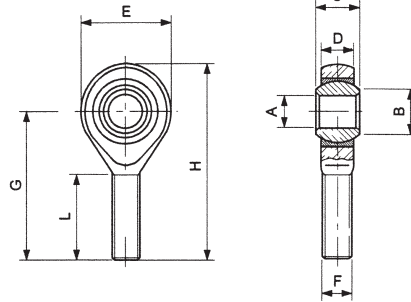

D : Dinamico
 Dynamic
 Dynamisch
 Dynamique
 Dinâmica
 Dinámico

S : Statico
 Static
 Statis
 Statique
 Estático
 Estático

Code	F	A	B	C	Ø Sfera Sphere Kugel Sphère Esfera Esfera	D	E	G	H	L	Carico radiale Radial load Radiallast Charge radiale Carga radial Carga radial	Peso Weight Gewicht Poids Peso Peso	
											D	S	
		0 H7	0	0 -0.13		±0.13	±0.5	±0.5		±0.7	kg	kg	g
TM 020	M5x0.8	5	7.5	8	11.11	7.5	18	33	42	19	430	1000	13
TM 032	M6x1	6	8.9	9	12.7	7.5	20	36	46	21	470	1100	15
TM 050	M8x1.25	8	10.4	12	15.88	9.5	24	42	54	25	780	1900	34
TM 080	M10x1.5	10	12.9	14	19.05	11.5	30	48	63	28	1200	3100	70
TM 100	M12x1.75	12	15.4	16	22.23	12.5	34	54	71	32	1400	3700	110

MATERIALE: Acciaio - MATERIAL: Steel - MATERIAL: Stahl - MATÉRIEL: Acier - MATERIAL: Acero - MATERIAL: Aço