

ELETTROVALVOLE SERVO-AZIONATE CON CORPO IN ACCIAIO INOX AISI 316L PER BOBINA ATEX "SERIE Y"

SERVO-ASSISTED SOLENOID VALVES WITH STAINLESS STEEL 316L BODY FOR "SERIES Y" ATEX COIL
SERVO-GESTEUERTE MAGNETVENTILE MIT KÖRPER EDELSTAHL AISI 316L FÜR SPULE ATEX
"Y-SERIE" ÉLECTROVANNES SERVO ASSISTEES AVEC CORPS EN ACIER INOX AISI 316L POUR BOBINE ATEX "SERIE Y"
ELECTROVALVULA SERVOACCIONADA CON CUERPO EN ACERO INOX AISI 316L PARA BOBINA "SERIE Y"
ELETTROVÁLVULAS SERVO-PILOTADAS COM CORPO EM AÇO INOX AISI 316L PARA BOBINA ATEX "SERIE Y"

AISI 316L

Ex
II 2 G/D Ex h



Serie X4A - Coil ATEX Ex d

Le elettrovalvole ATEX serie X4A – servozionate con corpo filettato in acciaio inox 316L – disponibili nella sola funzione 2/2 NC, si identificano per la possibilità di gestire portate elevate, avere un'ottima compatibilità a contatto con fluidi aggressivi e corrosivi e per essere installate in atmosfere potenzialmente esplosive grazie all'utilizzo esclusivo con la bobina ATEX serie Y avente custodia a prova di esplosione con marcatura Ex d / Ex tb. Anche la parte meccanica (valvola) è certificata ATEX II 2G/D Ex h, a completamento della garanzia del prodotto.

Principali vantaggi

- Installazione in atmosfere potenzialmente esplosive
- Valvola certificata ATEX II 2G/D Ex h
- Bobina certificata ATEX II 2G/D Ex d / Ex tb
- Contatto con fluidi aggressivi e corrosivi
- Conessioni da 1/4" a 1"
- Orifici dal Ø 10 mm al Ø 25 mm
- Pressioni di lavoro fino a 25 bar

Applicazioni

- Industria Chimica e Metallurgica
- Oil & Gas
- Ossigeno e Idrogeno
- Oli, Liquidi neutri e corrosivi
- Gas inerti e aggressivi

The ATEX X4A series solenoid valves – servo-assisted with 316L stainless steel threaded body – available in the 2/2 NC function only, are identified by the possibility of managing high flow rates, having excellent compatibility in contact with aggressive and corrosive fluids and be installed in potentially explosive atmospheres thanks to the exclusive use with the Y series ATEX coil having an explosion-proof enclosure with marking Ex d / Ex tb.

Even the mechanical part (valve) is ATEX II 2G/D Ex h certified, completing the product warranty.

Main advantages

- Installation in potentially explosive atmospheres
- Valve certified ATEX II 2G/D Ex h
- Coil certified ATEX II 2G/D Ex d / Ex tb
- Contact with aggressive and corrosive fluids
- Connections from 1/4" to 1"
- Orifices from Ø 10 mm up to Ø 25 mm
- Working pressures up to 25 bar

Applications

- Chemical and Metallurgical industry
- Oil & Gas
- Oxygen and Hydrogen
- Oils, Neutral and corrosive liquids
- Inert and aggressive gases

Die servogesteuerten ATEX-Magnetventile der Serie X4A – mit einem Gewindekörper aus Edelstahl 316L, sind in der Funktion 2/2 NC verfügbar. Sie zeichnen sich insbesondere für hohe Durchflussmengen sowie dem Einsatz in aggressiven und korrosiven Flüssigkeiten aus. Durch die ausschließliche Verwendung der ATEX-Spule der Serie Y, die über ein explosionsssicheres Gehäuse mit der Kennzeichnung Ex d / Ex tb verfügt, ist eine Installation in explosionsgefährdeten Bereichen möglich.

Auch der mechanische Teil (Ventil) ist nach ATEX II 2G/D Ex h zertifiziert, was die Produktsicherheit gewährleistet.

Vorteile

- Installation in explosionsgefährdeten Bereichen
- Ventil zertifiziert nach ATEX II 2G/D Ex h
- Spule zertifiziert nach ATEX II 2G/D Ex d / Ex tb
- Kontakt mit aggressiven und korrosiven Fluiden
- Anschlüsse von 1/4" bis 1"
- Öffnungen von Ø 10 mm bis zu Ø 25 mm
- Betriebsdruck bis zu 25 bar

Anwendungen

- Chemische und metallurgische Industrie
- Öl und Gas
- Sauerstoff und Wasserstoff
- Öle, neutrale und korrosive Flüssigkeiten
- Inerte und aggressive Gase

Les électrovanne de la série ATEX X4A – servo-assistées avec corps fileté en acier inoxydable 316L – disponibles uniquement en fonction 2/2 NF, s'identifient par la possibilité de gérer des débits élevés, ayant une excellente compatibilité au contact de fluides agressifs et corrosifs et peut être installé dans des atmosphères potentiellement explosives grâce à l'utilisation exclusive avec la bobine ATEX de la série Y ayant une enveloppe antidéflagrante avec marquage Ex d / Ex tb.

La partie mécanique (vanne) est également certifiée ATEX II 2G/D Ex h, complétant ainsi la garantie du produit.

Principaux avantages

- Installation en atmosphères potentiellement explosives
- Vanne certifiée ATEX II 2G/D Ex h
- Bobine certifiée ATEX II 2G/D Ex d / Ex tb
- Contact avec des fluides agressifs et corrosifs
- Connexions de 1/4" à 1"
- Orifices de Ø 10 mm à Ø 25 mm
- Pression jusqu'à 25 bar

Applications

- Industrie chimique et métallurgique
- Gaz et pétrole
- Oxygène et Hydrogène
- Huiles, Liquides neutres et corrosifs
- Gaz inertes et agressifs

Las electroválvulas de la serie ATEX X4A (servoasistidas con cuerpo roscado de acero inoxidable 316L) disponibles solo en la función 2/2 NC, se identifican por la posibilidad de gestionar caudales elevados, tener una excelente compatibilidad en contacto con fluidos agresivos y corrosivos y ser instaladas en atmósferas potencialmente explosivas gracias al uso exclusivo con la bobina ATEX de la serie Y que tiene una encapsulado a prueba de explosiones con marcado Ex d / Ex tb.

Incluso la parte mecánica (válvula) está certificada ATEX II 2G/D Ex h, completando la garantía del producto.

Principales ventajas

- Instalación en atmósferas potencialmente explosivas
- Válvula certificada ATEX II 2G/D Ex h
- Bobina certificada ATEX II 2G/D Ex d / Ex tb
- Contacto con fluidos agresivos y corrosivos
- Conexiones de 1/4" a 1"
- Orificios desde Ø 10 mm hasta Ø 25 mm
- Presiones de trabajo hasta 25 bar

Aplicaciones

- Industria química y metalúrgica
- Gas y petróleo
- Oxígeno e Hidrógeno
- Aceites, Líquidos neutros y corrosivos
- Gases inertes y agresivos

As válvulas solenóide da série ATEX X4A – servo-assistidas com corpo roscado em aço inox 316L – disponíveis apenas na função 2/2 NC, são identificadas pela possibilidade de gerenciar altas vazões, possuindo excelente compatibilidade em contato com fluidos agressivos e corrosivos e por possibilitar sua instalação em atmosferas potencialmente explosivas graças ao uso exclusivo com a bobina ATEX série Y com invólucro à prova de explosão com marcação Ex d / Ex tb.

Mesmo a parte mecânica (válvula) possui certificação ATEX II 2G/D Ex h, completando a garantia do produto.

Principais vantagens

- Instalação em atmosferas potencialmente explosivas
- Válvula certificada ATEX II 2G/D Ex h
- Bobina certificada ATEX II 2G/D Ex d / Ex tb
- Contato com fluidos agressivos e corrosivos
- Conexões de 1/4" a 1"
- Orifícios de Ø 10 mm até Ø 25 mm
- Pressões de trabalho até 25 bar

Aplicações

- Indústria Química e Metalúrgica
- Gás de petróleo
- Oxigênio e Hidrogênio
- Óleos, líquidos neutros e corrosivos
- Gases inertes e agressivos



Caratteristiche generali - X4A	IT	General features - X4A	GB	Eigenschaften - X4A	DE
- Posizione di montaggio consigliata orizzontale - Certificazione valvola: ATEX II 2G/D Ex h - Certificazione bobina: ATEX II 2G/D Ex d, Ex tb		- Recommended horizontal mounting position - Valve certification: ATEX II 2G/D Ex h - Coil certification: ATEX II 2G/D Ex d, Ex tb		- Horizontale Einbaulage empfohlen - Ventilzertifizierung: ATEX II 2G/D Ex h - Spulezertifizierung: ATEX II 2G/D Ex d, Ex tb	
Caractéristiques générales - X4A	FR	Características generales - X4A	ES	Características gerais - X4A	PT
- Position de montage horizontale recommandée - Certification des vannes: ATEX II 2G/D Ex h - Certification de bobine: ATEX II 2G/D Ex d, Ex tb		- Posición de montaje recomendada horizontal - Certificación de válvula: ATEX II 2G/D Ex h - Certificación de bobina: ATEX II 2G/D Ex d, Ex tb		- Posição de montagem aconselhada horizontal - Certificação de válvula: ATEX II 2G/D Ex h - Certificação de bobina: ATEX II 2G/D Ex d, Ex tb	



Tabella dei codici di ordinazione

Ordering codes

Bestellschlüssel

Composition de la référence de commande

Tabla para definición de código

Tabela de código de compra

SERIE	Connessione Port size Masse Dimension Tamaño Tamanho	Funzione Functions Funktion Fonctions Función Funções	Orifizio Orifice Dn Passage Orifizio Orifício	Materiale guarnizioni Sealing materials Dichtungswerkstoffe Matériaux des joints Material juntas Material das vedações	Versione Version Ausführung Version Versión Versão	Filettatura Thread Gewinde Filetage Rosca Rosca
-------	---	--	--	---	---	--

X	4	A	03	03	1	10	N	H	<input type="checkbox"/>
03 = 1/4"	04 = 3/8"	05 = 1/2"	07 = 3/4"	09 = 1"	1 = 2/2 NC	10 = 10 mm 14 = 14 mm 18 = 18 mm 25 = 25 mm	N = NBR E = EPDM V = FKM	H = Senza comando manuale Without manual override Ohne handbetätigung Sans commande manuelle Sin comando manual Sem acionamento manual	= Gas N = NPTF

BOBINA: SERIE Y

COIL: SERIES Y

SPULE: SERIES Y

BOBINE: SÉRIES Y

BOBINA: SÉRIES Y

BOBINA: SÉRIES Y

PAG: 19.8

PAG: 19.8

PAG: 19.8

PAG: 19.8

PAG: 19.8

PAG: 19.8



SERIE X4A - ATEX

ELETTROVALVOLE SERVO-AZIONATE CON CORPO IN ACCIAIO INOX AISI 316L PER BOBINA ATEX "SERIE Y"

SERVO-ASSISTED SOLENOID VALVES WITH STAINLESS STEEL AISI 316L BODY FOR "SERIES Y" ATEX COIL
 SERVO-GESTEUERTE MAGNETVENTILE MIT KÖRPER EDELSTAHL AISI 316L FÜR SPULE ATEX "Y-SERIE"
 ÉLECTROVANNES SERVO ASSISTEES AVEC CORPS EN ACIER INOX AISI 316L POUR BOBINE ATEX "SERIE Y"
 ELECTROVALVULA SERVOACCIONADA CON CUERPO EN ACERO INOX AISI 316L PARA BOBINA ATEX "SERIE Y"
 ELETRÓVALVULAS SERVO-PILOTADAS COM CORPO EN AÇO INOX AISI 316L PARA BOBINA ATEX "SERIE Y"

2/2 NC

1/4" → 1"

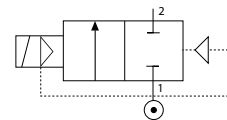

Anello di sfasamento argentato su richiesta
 Silver-plated shading ring on request
 Versilberter Schattierungsring auf anfrage
 Anneau d'ombrage argentée sur demande
 Anillo de sombreado plateado bajo pedido
 Anel de sombreamento banhado a prata sob pedido

Bobine certificate ATEX
 ATEX certified coils
 ATEX zertifizierte spule
 Bobine certifiées ATEX
 Bobina con certificación ATEX
 Bobina certificadas ATEX

Materiali e Componenti	IT	Materials and Components	GB	Materialien und Komponenten	DE
1 Corpo: Acciaio Inox AISI 316L		1 Body: Stainless steel AISI 316L		1 Körper: Edelstahl AISI 316L	
2 Tenute: NBR - EPDM - FKM		2 Seals: NBR - EPDM - FKM		2 Dichtung: NBR - EPDM - FKM	
3 Tubo guida: Acciaio Inox		3 Armature tube: Stainless steel		3 Führungsrohr: Edelstahl	
4 Nucleo fisso e mobile: Acciaio Inox AISI 430FR		4 Fixed and mobile core: Stainless steel AISI 430FR		4 Kern: Edelstahl AISI 430FR	
5 Molle: Acciaio Inox		5 Springs: Stainless steel		5 Feder: Edelstahl	
6 Anello di sfasamento: Rame		6 Shading ring: Copper		6 Schattierung Ring: Kupfer	

Matériaux et Composants	FR	Materiales y componentes	ES	Materialis e Componentes	PT
1 Corps: Acier inox AISI 316L		1 Cuerpo: Acero inox AISI 316L		1 Corpo: Aço-inox AISI 316L	
2 Joints: NBR - EPDM - FKM		2 Juntas: NBR - EPDM - FKM		2 Vedações: NBR - EPDM - FKM	
3 Tube de pilotage: Acier inox		3 Tubo guía: Acero inox		3 Tubo Guia: Aço-inox	
4 Noyau: Acier inox AISI 430FR		4 Núcleo fijo y móvil: Acero inox AISI 430FR		4 Núcleo fixo e móvel I: Aço-inox AISI 430FR	
5 Ressort: Acier inox		5 Muelle: Acero inox		5 Mola: Aço-inox	
6 Anneaux d'ombrage : cuivre		6 Anillo de sombreado: Cobre		6 Anel de sombreamento: Cobre	

Pressione massima ammissibile
 Maximum allowable pressure
 Max. Betriebsdruck
 Pression de service max.
 Presión máxima admisible
 Pressão máxima admissível

25 bar

Tabella compatibilità e materiali
 Compatibility and materials table
 Beständigkeitsübersicht
 Tableau de compatibilité des matériaux
 Tabla de compatibilidad de materiales
 Tabela de compatibilidade química

Pag. 0.21 - 0.22

Valvola e bobina fornite separatamente
 Valve and coil supplied separately
 Ventil und Spule separat erhältlich
 Vanne et bobine fournies séparément
 Válvula y bobina suministradas por separado
 Válvula e bobina fornecidas separadamente

OPZIONI SU RICHIESTA - OPTIONS ON REQUEST - OPTIONEN AUF ANFRAGE - OPTIONS SUR DEMANDE - OPCIONES BAJO PEDIDO - OPÇÕES SOB ENCOMENDA

Anello di sfasamento argentato - Silver-plated shading ring - Versilberter Schattierungsring
 Anneau d'ombrage argentée - Anillo de sombreado plateado - Anel de sombreamento banhado a prata

Versione idonea per utilizzo con ossigeno industriale - Version suitable for use with industrial oxygen - Version für industrie sauerstoff
 Version adaptée à une utilisation avec de l'oxygène industriel - Versión idónea para el uso con oxígeno industrial - Versão adequada para utilização com oxigênio industrial

Code	Materiale tenuta Sealing materials Dichtungswerkstoffe Matériau joint Material juntas Material das vedações	Conessioni Port size Verbindungen Connexions Conexiones Conexões	Ø Orifizio Ø Orifice Ø Dn Ø Passage Ø Orificio Ø Orificio	Viscosità Viscosity Viskosität Viscosité Viscosidad Viscosidade	Kv	Pressione differenziale (OPD) Differential pressure (OPD) Differenzdruck (OPD) Pression différentielle (OPD) Presión diferencial (OPD) Pressão diferencial (OPD)			Potenza Power Leistung Puissance Potencia		Bobine Coils Spulen Bobines Bobinas Bobinas	
						Min	Max DC	Max AC	DC W	AC VA	Size mm	Serie Y - pag. 19.8
	①	ISO 228	mm	cSt	m ³ /h	Bar						

H Senza comando manuale - Without manual override - Ohne handbetätigung Sans commande manuelle - Sin comando manual - Sem acionamento manual												
X4A 03 1 10 _ H	N = NBR -10°C +90°C V = FKM -10°C +140°C E = EPDM -10°C +140°C	1/4"	10	25	1.88	0.15	20	20	8	12	50	Y - SOLY0
X4A 04 1 14 _ H		3/8"	14	25	3.32	0.15	20	20	8	12	50	Y - SOLY0
X4A 05 1 14 _ H		1/2"	14	25	3.53	0.15	20	20	8	12	50	Y - SOLY0
X4A 07 1 18 _ H		3/4"	18	25	5.56	0.15	20	20	8	12	50	Y - SOLY0
X4A 09 1 25 _ H		1"	25	25	10.97	0.15	20	20	8	12	50	Y - SOLY0

① **Selezionare tenuta - Select seal material - Wählen Sie das Dichtungsmaterial aus - Sélectionner matériau d'étanchéité - Seleccionar material sellado - Seleccionar material de vedação**

EPDM - P max= 2.5 bar: Con vapore - With steam - Mit dampf - Avec vapeur - Con vapor - Com vapor

Bobina non inclusa - Coil not included - Magnetspulen separat - Bobines non incluse - Bobina no incluida - Bobinas não incluídas

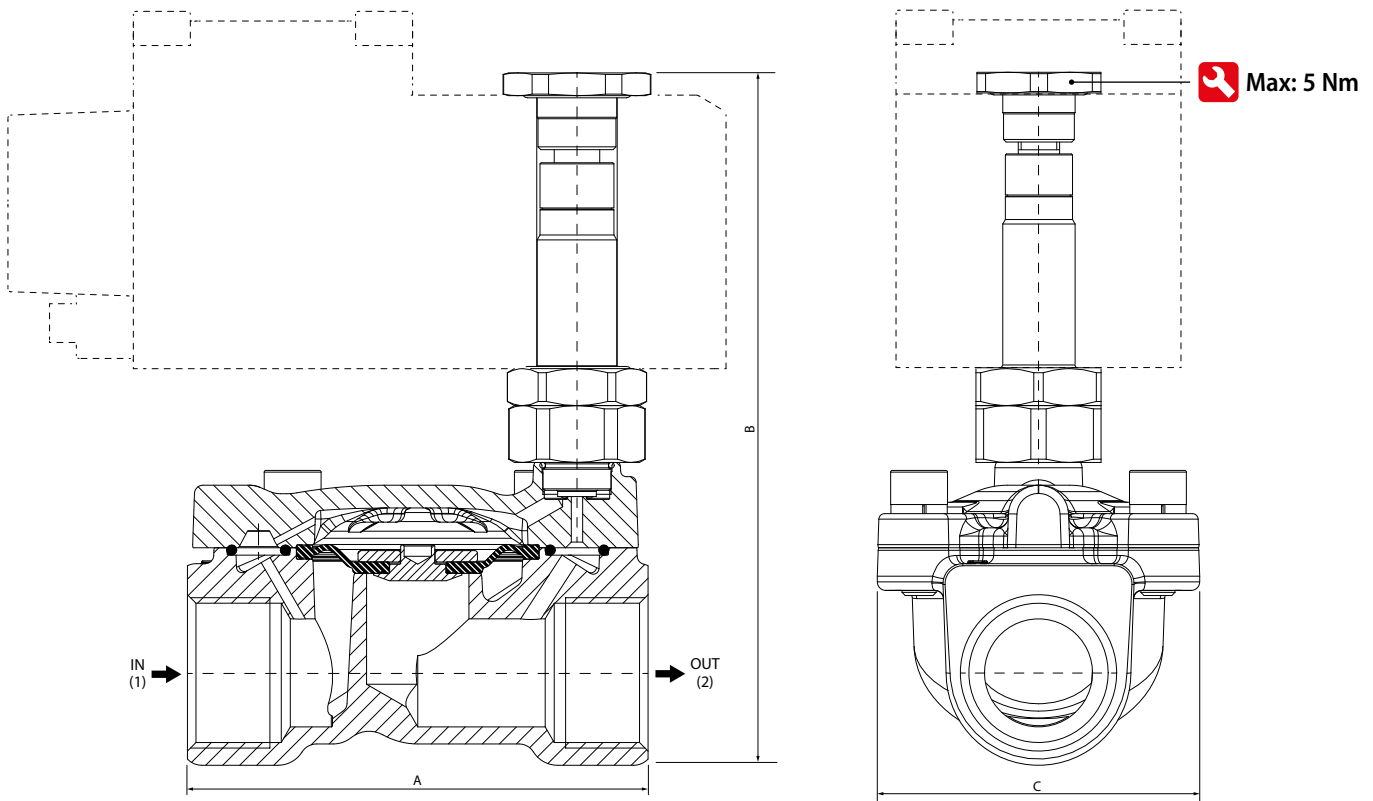

Size	A	B	C
1/4"	55.5	103.5	35.2
3/8"	65.3	111.1	46.4
1/2"	65.3	111.1	46.4
3/4"	1	121.9	56.7
1"	5	128	65

22 mm



Serie A
Pag. 19.2

UL
CSA C22.2

30 mm



Serie B
Pag. 19.3

UL
CSA C22.2

30 mm



Serie X
Pag. 19.4

Ex

30 mm



Serie C
Pag. 19.5

UL
CSA C22.2

30 mm



Serie D
Pag. 19.6

UL
CSA C22.2

36 mm



Serie E
Pag. 19.7

UL
CSA C22.2

50 mm



Serie Y
Pag. 19.8

Ex

Connectors

Coils & Connectors



Connectors
Pag. 19.9 / 19.10

UL
CSA C22.2

Aignep si riserva il diritto di variare modelli e ingombri senza preavviso - Aignep reserves the right to vary models and dimensions without notice - Aignep behält sich das Recht vor, Daten ohne Ankündigung zu ändern
Aignep se reserva el derecho de modificar modelos y dimensiones sin previo aviso - Aignep se réserve le droit de modifier les données sans préavis

BOBINE E CONNETTORI

COILS AND CONNECTORS

SPULEN UND STECKER

BOBINES ET CONNECTEURS

BOBINAS Y CONECTORES

BOBINAS E CONECTORES



Coils & Connectors

Aignep offre un'ampia gamma di bobine e connettori standard (su richiesta anche in configurazione speciale) per soddisfare qualsiasi tipo di esigenza applicativa.

Le bobine sono disponibili in diverse taglie, con servizio continuo ED 100%, differenti potenze e nelle tensioni standard 12 / 24 VDC e 24 / 110 / 220 VAC; l'isolamento in classe H e la certificazione UL Recognized sono garantiti su tutte le bobine.

Sono altresì disponibili le versioni certificate ATEX per installazione in ambienti potenzialmente esplosivi (Ex mb e Ex d/tb).

I connettori sono disponibili con grado di protezione IP67 e nelle versioni standard con involucro nero o trasparente con led di segnalazione, oltre alla versione certificata UL Recognized.

Aignep offers a wide range of standard coils and connectors (on request also in special configuration) to satisfy any type of application requirement.

The coils are available in different sizes, with continuous duty ED 100%, different powers and in the standard voltages 12 / 24 VDC and 24 / 110 / 220 VAC; class H insulation and UL Recognized certification are guaranteed on all coils.

ATEX certified versions are also available for installation in potentially explosive environments (Ex mb and Ex d/tb).

The connectors are available with IP67 protection degree and in the standard versions with black case or transparent case with LED, in addition to the UL Recognized certified version.

Aignep bietet eine breite Palette von Standardspulen und Steckern (auf Anfrage auch in Sonderkonfiguration) an, um jede Art von Anwendungsanforderung zu erfüllen.

Die Spulen sind in verschiedenen Größen, mit Dauerbetrieb ED 100%, in verschiedenen Leistungen und in den Standardspannungen 12 / 24 VDC und 24 / 110 / 220 VAC erhältlich. Alle Magnetspulen haben die Isolierklasse H und haben eine UL-Zertifizierung.

ATEX-zertifizierte Versionen für die Installation in explosionsgefährdeten Umgebungen (Ex mb und Ex d/tb) sind ebenfalls erhältlich.

Die Stecker sind in der Schutzart IP67 und in den Standardversionen mit schwarzem Gehäuse oder transparentem Gehäuse mit LED erhältlich, zusätzlich zur UL-zertifizierten Version.

Aignep propose une large gamme de bobines et de connecteurs standards (sur demande également en configuration spéciale) pour répondre à tout type d'exigence d'application.

Les bobines sont disponibles en différentes tailles, avec service continu ED 100%, différentes puissances et dans les tensions standard 12 / 24 VDC et 24 / 110 / 220 VAC; l'isolation de classe H et la certification reconnue UL sont garanties sur toutes les bobines.

Des versions certifiées ATEX sont également disponibles pour une installation dans des environnements potentiellement explosifs (Ex mb et Ex d/tb).

Les connecteurs sont disponibles avec un degré de protection IP67 et dans les versions standard avec boîtier noir ou boîtier transparent avec LED, en plus de la version certifiée UL.

Aignep ofrece una amplia gama de bobinas y conectores estándar (bajo pedido también en configuración especial) para satisfacer cualquier tipo de requisito de aplicación.

Las bobinas están disponibles en diferentes tamaños, con servicio continuo ED 100%, diferentes potencias y en los voltajes estándar 12/24 VDC y 24/110/220 VAC; El aislamiento de clase H y la certificación reconocida por UL están garantizados en todas las bobinas.

Las versiones certificadas ATEX también están disponibles para su instalación en entornos potencialmente explosivos (Ex mb y Ex d/tb).

Los conectores están disponibles con grado de protección IP67 en las versiones estándar con caja negra o caja transparente con LED, además de la versión certificada UL Recognized.

A Aignep oferece uma ampla gama de bobinas e conectores padrão (sob encomenda também em configurações especiais) para satisfazer qualquer tipo de exigência de aplicação.

As bobinas estão disponíveis em diversos tamanhos, com regime contínuo ED 100%, diferentes potências e nas tensões padrão 12 / 24 VDC e 24 / 110 / 220 VAC; classe de isolamento H e certificação UL reconhecida para todas as bobinas.

Versões com certificação ATEX também estão disponíveis para instalação em ambientes potencialmente explosivos (Ex mb e Ex d/tb).

Os conectores estão disponíveis com grau de proteção IP67 e nas versões padrão com caixa preta ou caixa transparente com LED, além da versão certificada UL Recognized.

AIGNEP
SRL
Sole proprietaria
S.p.A.
Via
C.E. S.p.A.

AIGNEP
SRL
Sole proprietaria
S.p.A.
Via
C.E. S.p.A.

AIGNEP
SRL
Sole proprietaria
S.p.A.
Via
C.E. S.p.A.

SERIE A

BOBINA

COIL
SPULE
BOBINE
BOBINA
SOLENOÏDE

22 mm 

10 mm 

ED 100% 

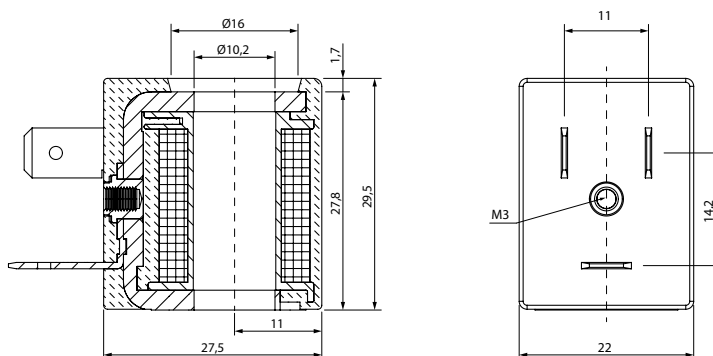

UL 429 & CSA C22.2 NO. 139-13

Riferimento <i>Reference Referenz Référéce Referéncia Referéncia</i>	Codice <i>Code Code Code Código Código</i>	Tensione <i>Voltage Leistung Tension Tensión Tensão</i>	Potenza <i>Power Leistung Puissance Potencia Potência</i>	Tolleranze di tensione <i>Voltage tolerance Spannungstoleranz Tolérance de la tension Tolerancia de tensión Tolerância de tensão</i>	Temperatura ambiente <i>Ambient temperature Umgebungstemperatur Température ambiante Temperatura ambiente Temperatura Ambiente</i>	
					Min	Max
AA	SOL10012C4000	12V DC	6.5 W	±10 %	-10 °C	+80 °C
AB	SOL10024C4000	24V DC	6.5 W	±10 %	-10 °C	+80 °C
A1	SOL10024A8000	24V AC / 50-60 Hz	7.5 VA	±10 %	-10 °C	+80 °C
A2	SOL10110A8000	110V AC / 50-60 Hz	7.5 VA	±10 %	-10 °C	+80 °C
A3	SOL10220A8000	220V AC / 50-60 Hz	7.5 VA	±10 %	-10 °C	+80 °C

CLASSE DI ISOLAMENTO
INSULATION CLASS
ISOLIERSTOFFKLASSE
CLASSE D'ISOLATION
CLASE DE AISLAMIENTO
CLASSE DE ISOLAMENTO

**H
EN 60085**

MATERIALE INCAPSULAMENTO
ENCAPSULATION MATERIAL
VERGUSSTMASSE
MATERIAUX EXTÉRIEUR
MATERIAL DE ENCAPSULAMIENTO
MATERIAL DE ENCAPSULAMENTO

RYNITE®

CONNESSIONI ELETTRICHE
ELECTRICAL CONNECTIONS
ELEKTRISCHE ANSCHLÜSSE
CONNEXIONS ELECTRIQUES
CONEXIÓN ELÉCTRICA
CONEXÕES ELÉTRICAS

**FORM
B - INDUSTRIAL**
EN 175301-803
(EX DIN 43650)

TEMPERATURA AMBIENTE
AMBIENT TEMPERATURE
UMGEBUNGSTEMPERATUR
TEMPÉRATURE AMBIANTE
TEMPERATURA AMBIENTE
TEMPERATURA AMBIENTE

**-10 °C
+80 °C**

GRADO DI PROTEZIONE
PROTECTION DEGREE
SCHUTZART
DEGRÉ DE PROTECTION
GRADO DE PROTECCIÓN
GRAU DE PROTEÇÃO

**IP67
IEC 60529**

Con connettore IP67
with connector IP67
Mit Stecker IP67
Avec connecteur IP67
Con conector IP67
Com conector IP67

OPZIONI
OPTIONS
OPTIONEN
OPTIONS
OPCIONES
OPÇÕES

Altre tensioni/potenze su richiesta
*Other voltages/powers on request
Andere Spannungen/Leistungen auf Anfrage
Autres tensions/puissances sur demandes
Otras tensiones-potencia bajo pedido
Outras tensões/potências sob encomenda*

SERIE B

BOBINA

COIL
SPULE
BOBINE
BOBINA
SOLENÓIDE



30 mm

10 mm

ED 100%

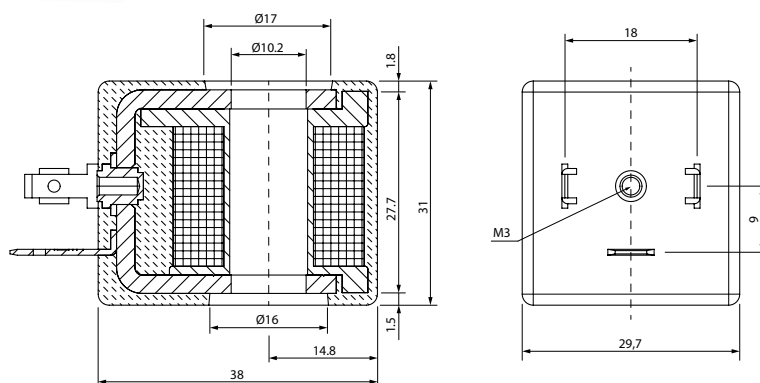

UL 429 & CSA C22.2 NO. 139-13

Riferimento Reference Referenz Référéce Referencia Referência	Codice Code Code Code Código Código	Tensione Voltage Leistung Tension Tensión Tensão	Potenza Function Leistung Puissance Potencia Potência	Tolleranze di tensione Voltage tolerance Spannungstoleranz Tolérance de la tension Tolerancia de tensión Tolerância de tensão	Temperatura ambiente Ambient temperature Umgebungstemperatur Température ambiante Temperatura ambiente Temperatura Ambiente	
					Min	Max
BA	SOL11012C5000	12V DC	8 W	±10 %	-10 °C	+80 °C
BB	SOL11024C5000	24V DC	8 W	±10 %	-10 °C	+80 °C
B1	SOL11024A9000	24V AC / 50-60 Hz	11 VA	±10 %	-10 °C	+80 °C
B2	SOL11110A9000	110V AC / 50-60 Hz	11 VA	±10 %	-10 °C	+80 °C
B3	SOL11220A9000	220V AC / 50-60 Hz	11 VA	±10 %	-10 °C	+80 °C

CLASSE DI ISOLAMENTO
INSULATION CLASS
ISOLIERSTOFFKLASSE
CLASSE D'ISOLATION
CLASE DE AISLAMIENTO
CLASSE DE ISOLAMENTO

H
EN 60085

MATERIALE INCAPSULAMENTO
ENCAPSULATION MATERIAL
VERGÜSSMASSE
MATERIAUX EXTÉRIEUR
MATERIAL DE ENCAPSULAMIENTO
MATERIAL DE ENCAPSULAMENTO

RYNITE®

CONNESSIONI ELETTRICHE
ELECTRICAL CONNECTIONS
ELEKTRISCHE ANSCHLÜSSE
CONNEXIONS ELECTRIQUES
CONEXIÓN ELÉCTRICA
CONEXÕES ELÉTRICAS

FORM A

EN 175301-803
(EX DIN 43650)

TEMPERATURA AMBIENTE
AMBIENT TEMPERATURE
UMGEBUNGSTEMPERATUR
TEMPÉRATURE AMBIANTE
TEMPERATURA AMBIENTE
TEMPERATURA AMBIENTE

-10 °C
+80 °C

GRADO DI PROTEZIONE
PROTECTION DEGREE
SCHUTZART
DEGRÉ DE PROTECTION
GRADO DE PROTECCIÓN
GRAU DE PROTEÇÃO

IP67
IEC 60529

Con connettore IP67
with connector IP67
Mit Stecker IP67
Avec connecteur IP67
Con conector IP67
Com conector IP67

OPZIONI
OPTIONS
OPTIONEN
OPTIONEN
OPCIONES
OPÇÕES

Altre tensioni/potenze su richiesta
Other voltages/powers on request
Andere Spannungen/Leistungen auf Anfrage
Autres tensions/puissances sur demandes
Otras tensiones-potencia bajo pedido
Outras tensões/potências sob encomenda

SERIE X

BOBINA

COIL
SPULE
BOBINE
BOBINA
SOLENÓIDE

30 mm 

10 mm 

ED 100% 



ATEX
II 2G Ex mb IIC T4 Gb
II 2D Ex mb IIIC T135°C Db
I M2 Ex mb I Mb
INERIS 06ATEX0002X

IECEX
Ex mb IIC T4 Gb
Ex mb IIIC T135°C Db
Ex mb I Mb
IECEX INE 15.0053X

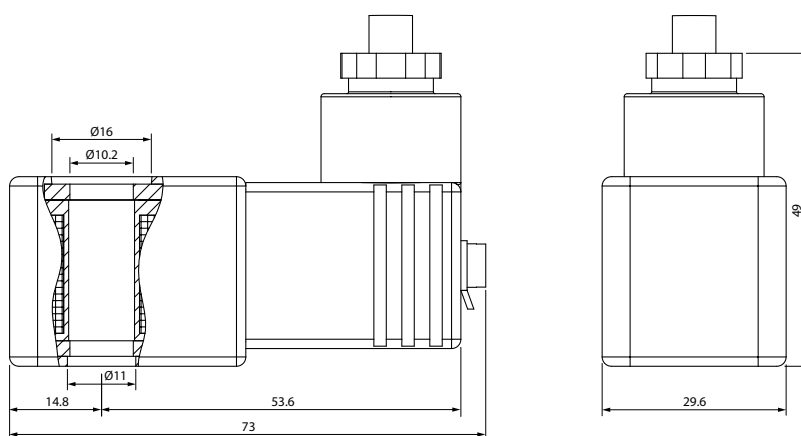

Riferimento <i>Reference</i> <i>Referenz</i> <i>Référence</i> <i>Referencia</i> <i>Referência</i>	Codice <i>Code</i> <i>Code</i> <i>Code</i> <i>Código</i> <i>Código</i>	Tensione <i>Voltage</i> <i>Leistung</i> <i>Tension</i> <i>Tensión</i> <i>Tensão</i>	Potenza <i>Power</i> <i>Leistung</i> <i>Puissance</i> <i>Potencia</i> <i>Potência</i>	Tolleranze di tensione <i>Voltage tolerance</i> <i>Spannungstoleranz</i> <i>Tolérance de la tension</i> <i>Tolerancia de tensión</i> <i>Tolerância de tensão</i>	Temperatura ambiente <i>Ambient temperature</i> <i>Umgebungstemperatur</i> <i>Température ambiante</i> <i>Temperatura ambiente</i> <i>Temperatura Ambiente</i>	
					Min	Max
XB	SOLX4024CE000	24V DC	5.3 W	±10 %	-20 °C	+40 °C
X1	SOLX4024AE000	24V AC / 50-60 Hz	5.3 W	±10 %	-20 °C	+40 °C
X2	SOLX4110AE000	110V AC / 50-60 Hz	5.3 W	±10 %	-20 °C	+40 °C
X3	SOLX4220AE000	230V AC / 50-60 Hz	5.3 W	±10 %	-20 °C	+40 °C

CLASSE DI ISOLAMENTO
CLASS OF ISOLATION
ISOLIERSTOFFKLASSE
CLASSE D'ISOLATION
CLASE DE AISLAMIENTO
CLASSE DE ISOLAMENTO

H
EN 60085

MATERIALE INCAPSULAMENTO
ENCAPSULATION MATERIAL
VERGUSSTMASSE
MATERIAUX EXTÉRIEUR
MATERIAL DE ENCAPSULAMIENTO
MATERIAL DE ENCAPSULAMENTO

POLYAMIDE

CONNESSIONI ELETTRICHE
ELECTRICAL CONNECTIONS
ELEKTRISCHE ANSCHLÜSSE
CONNEXIONS ELECTRIQUES
CONEXIÓN ELÉCTRICA
CONEXÕES ELÉTRICAS

3 Mt.

Cavo tripolare
Three-pole cable
3-adriges Kabel
Câble tripolaire
Cable tripolar
Cabo tripolar

GRADO DI PROTEZIONE
DEGREE OF PROTECTION
SCHUTZART
DEGRÉ DE PROTECTION
GRADO DE PROTECCIÓN
GRAU DE PROTEÇÃO

IP6_
IEC 60529
In base al cablaggio
According to wiring
Je nach Verdrahtung
Selon le câblage
Según el cableado
Acordo o cabeamento

CARATTERISTICHE
FEATURES
EIGENSCHAFTEN
CARACTÉRISTIQUES
CARACTERÍSTICA
CARACTERÍSTICAS

Fusibile interno
Internal fuse
Interne Sicherung
Fusible interne
Fusível interno

NORMATIVE ATEX
ATEX REGULATIONS
ATEX RICHTLINIEN
NORMATIVE ATEX
NORMATIVA ATEX
NORMATIVA ATEX

EN 60079-0
EN 60079-18

SERIE C

BOBINA

COIL
SPULE
BOBINE
BOBINA
SOLENÓIDE



30 mm

13 mm

ED 100%



UL 429 & CSA C22.2 NO. 139-13

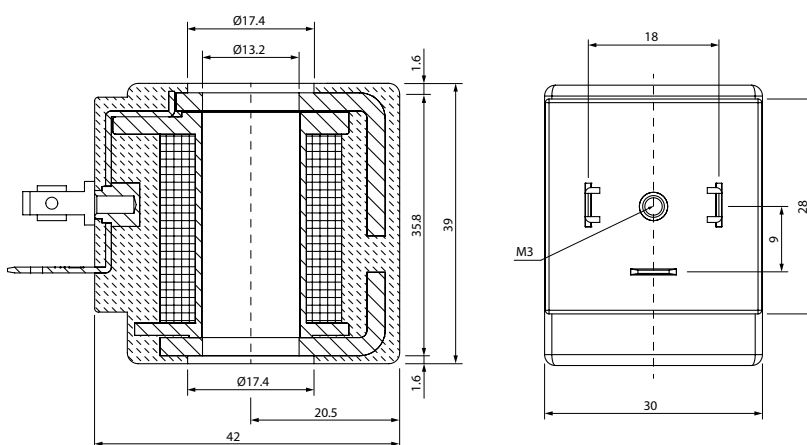

Riferimento Reference Referenz Référéce Referencia Referência	Codice Code Code Code Código Código	Tensione Voltage Leistung Tension Tensión Tensão	Potenza Function Leistung Puissance Potencia Potência	Tolleranze di tensione Voltage tolerance Spannungstoleranz Tolérance de la tension Tolerancia de tensión Tolerância de tensão	Temperatura ambiente Ambient temperature Umgebungstemperatur Température ambiante Temperatura ambiente Temperatura Ambiente	
					Min	Max
CA	SOL20012C5000	12V DC	8 W	±10 %	-10 °C	+80 °C
CB	SOL20024C5000	24V DC	8 W	±10 %	-10 °C	+80 °C
C1	SOL20024AA000	24V AC / 50-60 Hz	14 VA	±10 %	-10 °C	+80 °C
C2	SOL20110AA000	110V AC / 50-60 Hz	14 VA	±10 %	-10 °C	+80 °C
C3	SOL20220AA000	220V AC / 50-60 Hz	14 VA	±10 %	-10 °C	+80 °C

CLASSE DI ISOLAMENTO
CLASS OF ISOLATION
ISOLIERSTOFFKLASSE
CLASSE D'ISOLATION
CLASE DE AISLAMIENTO
CLASSE DE ISOLAMENTO

H
EN 60085

MATERIALE INCAPSULAMENTO
ENCAPSULATION MATERIAL
VERGÜSSMASSE
MATERIAUX EXTÉRIEUR
MATERIAL DE ENCAPSULAMIENTO
MATERIAL DE ENCAPSULAMENTO

RYNITE®

CONNESSIONI ELETTRICHE
ELECTRICAL CONNECTIONS
ELEKTRISCHE ANSCHLÜSSE
CONNEXIONS ELECTRIQUES
CONEXIÓN ELÉCTRICA
CONEXÕES ELÉTRICAS

FORM A

EN 175301-803
(EX DIN 43650)

TEMPERATURA AMBIENTE
AMBIENT TEMPERATURE
UMGEBUNGSTEMPERATUR
TEMPÉRATURE AMBIANTE
TEMPERATURA AMBIENTE
TEMPERATURA AMBIENTE

-10 °C
+80 °C

GRADO DI PROTEZIONE
PROTECTION DEGREE
SCHUTZART
DEGRÉ DE PROTECTION
GRADO DE PROTECCIÓN
GRAU DE PROTEÇÃO

IP67
IEC 60529

Con connettore IP67
with connector IP67
Mit Stecker IP67
Avec connecteur IP67
Con conector IP67
Com conector IP67

OPZIONI
OPTIONS
OPTIONEN
OPÇÕES

Altre tensioni/potenze su richiesta
Other voltages/powers on request
Andere Spannungen/Leistungen auf Anfrage
Autres tensions/puissances sur demandes
Otras tensiones-potencia bajo pedido
Outras tensões/potências sob encomenda

SERIE D

BOBINA

COIL
SPULE
BOBINE
BOBINA
SOLENOÏDE



30 mm

13 mm

ED 100%



UL 429 & CSA C22.2 NO. 139-13

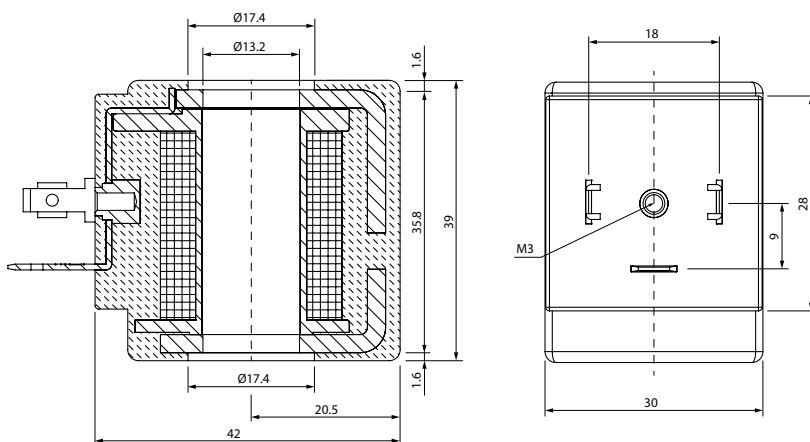

Riferimento <i>Reference</i> <i>Referenz</i> <i>Référence</i> <i>Referencia</i> <i>Referência</i>	Codice <i>Code</i> <i>Code</i> <i>Code</i> <i>Código</i> <i>Código</i>	Tensione <i>Voltage</i> <i>Leistung</i> <i>Tension</i> <i>Tensión</i> <i>Tensão</i>	Potenza <i>Function</i> <i>Leistung</i> <i>Puissance</i> <i>Potencia</i> <i>Potência</i>	Tolleranze di tensione <i>Voltage tolerance</i> <i>Spannungstoleranz</i> <i>Tolérance de la tension</i> <i>Tolerancia de tensión</i> <i>Tolerância de tensão</i>	Temperatura ambiente <i>Ambient temperature</i> <i>Umgebungstemperatur</i> <i>Température ambiante</i> <i>Temperatura ambiente</i> <i>Temperatura Ambiente</i>	
					Min	Max
DA	SOL20012C6000	12V DC	14 W	±10 %	-10 °C	+80 °C
DB	SOL20024C6000	24V DC	14 W	±10 %	-10 °C	+80 °C
D1	SOL20024AB000	24V AC / 50-60 Hz	21 VA	±10 %	-10 °C	+80 °C
D2	SOL20110AB000	110V AC / 50-60 Hz	21 VA	±10 %	-10 °C	+80 °C
D3	SOL20220AB000	220V AC / 50-60 Hz	21 VA	±10 %	-10 °C	+80 °C

CLASSE DI ISOLAMENTO

INSULATION CLASS
ISOLIERSTOFFKLASSE
CLASSE D'ISOLATION
CLASE DE AISLAMIENTO
CLASSE DE ISOLAMENTO

H
EN 60085

MATERIALE INCAPSULAMENTO

ENCAPSULATION MATERIAL
VERGUSSTMASSE
MATERIAUX EXTÉRIEUR
MATERIAL DE ENCAPSULAMIENTO
MATERIAL DE ENCAPSULAMENTO

RYNITE®

CONNESSIONI ELETTRICHE

ELECTRICAL CONNECTIONS
ELEKTRISCHE ANSCHLÜSSE
CONNEXIONS ELECTRIQUES
CONEXIÓN ELÉCTRICA
CONEXÕES ELÉTRICAS

FORM A

EN 175301-803
(EX DIN 43650)

TEMPERATURA AMBIENTE

AMBIENT TEMPERATURE
UMGEBUNGSTEMPERATUR
TEMPÉRATURE AMBIANTE
TEMPERATURA AMBIENTE
TEMPERATURA AMBIENTE

-10 °C
+80 °C

GRADO DI PROTEZIONE

PROTECTION DEGREE
SCHUTZART
DEGRÉ DE PROTECTION
GRADO DE PROTECCIÓN
GRAU DE PROTEÇÃO

IP67
IEC 60529

Con connettore IP67
with connector IP67
Mit Stecker IP67
Avec connecteur IP67
Con conector IP67
Com conector IP67

OPZIONI

OPTIONS
OPTIONEN
OPTIONS
OPCIONES
OPÇÕES

Altre tensioni/potenze su richiesta

Other voltages/powers on request
Andere Spannungen/Leistungen auf Anfrage
Autres tensions/puissances sur demandes
Otras tensiones-potencia bajo pedido
Outras tensões/potências sob encomenda

SERIE E

BOBINA

COIL
SPULE
BOBINE
BOBINA
SOLENÓIDE



36 mm

13 mm

ED 100%



UL 429 & CSA C22.2 NO. 139-13

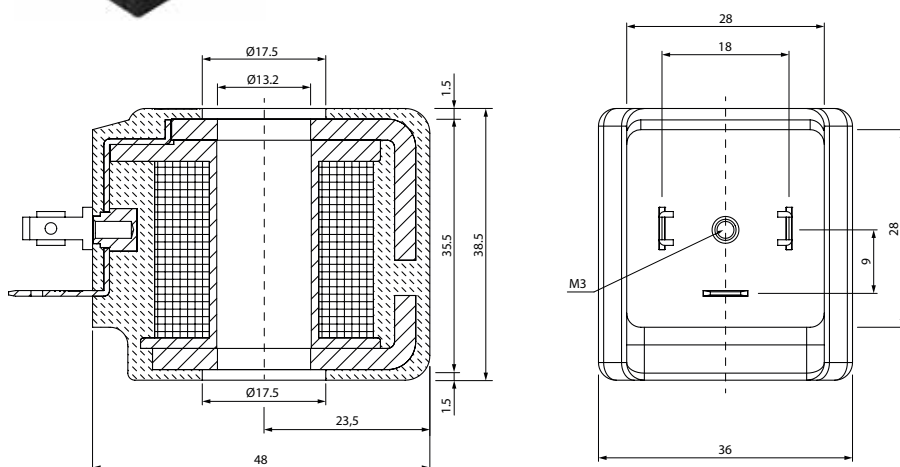

Riferimento Reference Referenz Référéce Referencia Referência	Codice Code Code Code Código Código	Tensione Voltage Leistung Tensión Tensão	Potenza Function Leistung Puissance Potencia Potência	Tolleranze di tensione Voltage tolerance Spannungstoleranz Tolérance de la tension Tolerancia de tensión Tolerância de tensão	Temperatura ambiente Ambient temperature Umgebungstemperatur Température ambiante Temperatura ambiente Temperatura Ambiente	
					Min	Max
EA	SOL21012C7000	12V DC	22 W	±10 %	-10 °C	+80 °C
EB	SOL21024C7000	24V DC	22 W	±10 %	-10 °C	+80 °C
E1	SOL21024AC000	24V AC / 50-60 Hz	31 VA	±10 %	-10 °C	+80 °C
E2	SOL21110AC000	110V AC / 50-60 Hz	31 VA	±10 %	-10 °C	+80 °C
E3	SOL21220AC000	220V AC / 50-60 Hz	31 VA	±10 %	-10 °C	+80 °C

CLASSE DI ISOLAMENTO
INSULATION CLASS
ISOLIERSTOFFKLASSE
CLASSE D'ISOLATION
CLASE DE AISLAMIENTO
CLASSE DE ISOLAMENTO

H
EN 60085

MATERIALE INCAPSULAMENTO
ENCAPSULATION MATERIAL
VERGÜSSMASSE
MATERIAUX EXTÉRIEUR
MATERIAL DE ENCAPSULAMIENTO
MATERIAL DE ENCAPSULAMENTO

RYNITE®

CONNESSIONI ELETTRICHE
ELECTRICAL CONNECTIONS
ELEKTRISCHE ANSCHLÜSSE
CONNEXIONS ELECTRIQUES
CONEXIÓN ELÉCTRICA
CONEXÕES ELÉTRICAS

FORM A
EN 175301-803
(EX DIN 43650)

TEMPERATURA AMBIENTE
AMBIENT TEMPERATURE
UMGEBUNGSTEMPERATUR
TEMPÉRATURE AMBIANTE
TEMPERATURA AMBIENTE
TEMPERATURA AMBIENTE

-10 °C
+80 °C

GRADO DI PROTEZIONE
PROTECTION DEGREE
SCHUTZART
DEGRÉ DE PROTECTION
GRADO DE PROTECCIÓN
GRAU DE PROTEÇÃO

IP67
IEC 60529
Con connettore IP67
with connector IP67
Mit Stecker IP67
Avec connecteur IP67
Con conector IP67
Com conector IP67

OPZIONI
OPTIONS
OPTIONEN
OPTIONEN
OPCIONES
OPÇÕES

Altre tensioni/potenze su richiesta
Other voltages/powers on request
Andere Spannungen/Leistungen auf Anfrage
Autres tensions/puissances sur demandes
Otras tensiones-potencia bajo pedido
Outras tensões/potências sob encomenda

SERIE Y

BOBINA

COIL
SPULE
BOBINE
BOBINA
SOLENOÏDE



50 mm

14 mm

ED 100%



ATEX II 2GD

Ex d IIC T6 o T5 o T4 Gb IP66

Ex tb IIIC T85°C o T100°C o T135°C Db IP66

CESI 03 ATEX 344/02

Tamb -40°C ÷ +35°C(T6) o +50°C(T5) o +60°C(T4)

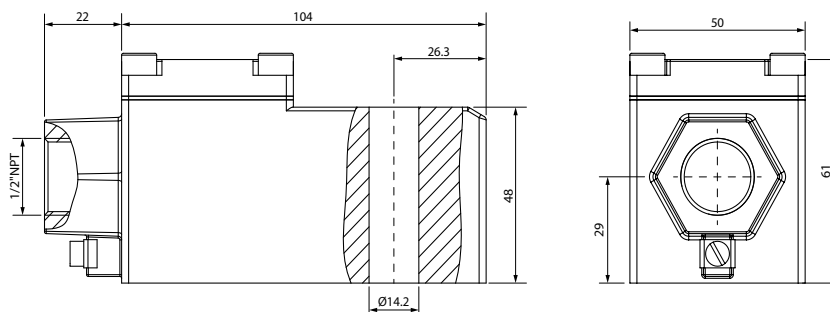

Riferimento Reference Referenz Référence Referencia Referência	Codice Code Code Code Código Código	Tensione Voltage Leistung Tension Tensión Tensão	Potenza Function Leistung Puissance Potencia Potência	Tolleranze di tensione Voltage tolerance Spannungstoleranz Tolérance de la tension Tolerancia de tensión Tolerância de tensão
YA	SOLY0012C5000	12V DC	8 W	±10 %
YB	SOLY0024C5000	24V AC / DC	8 W	±10 %
Y2	SOLY0110C5000	110V/120V AC / DC	8 W	±10 %
Y3	SOLY0220C5000	220V/240V AC / DC	8 W	±10 %

CLASSE DI ISOLAMENTO
CLASS OF ISOLATION
ISOLIERSTOFFKLASSE
CLASSE D'ISOLATION
CLASE DE AISLAMIENTO
CLASSE DE ISOLAMENTO

H
EN 60085

MATERIALE CUSTODIA
CASE MATERIAL
GEHÄUSEMATERIAL
MATERIAU DU BOITIER
MATERIAL DE LA CAJA
MATERIAL DA CAPA

ALUMINIUM

Acciaio Inox su richiesta
Stainless Steel on request
Edelstahl auf anfrage
acier inoxydable sur demande
acero inoxidable bajo pedido
aço inoxidável sob encomenda

CERTIFICAZIONI SU RICHIESTA
CERTIFICATIONS ON REQUEST
ZERTIFIZIERUNGEN AUF ANFRAGE
CERTIFICATIONS SUR DEMANDE
CERTIFICACIONES BAJO SOLICITUD
CERTIFICAÇÕES SOB ENCOMENDA

EAC
INMETRO
CCOE
PESO
CCC

GRADO DI PROTEZIONE
DEGREE OF PROTECTION
SCHUTZART
DEGRÉ DE PROTECTION
GRADO DE PROTECCIÓN
GRAU DE PROTEÇÃO

IP66
IEC 60529

INGRESSO CAVI
CABLE ENTRY
KABELDURCHFÜHRUNGEN
ENTRÉE DE CÂBLE
ENTRADA DE CABLE
ENTRADA DE CABOS

1/2" NPT

Su richiesta M20x1.5
On request M20x1.5
Auf Anfrage M20x1.5
Sur demande M20x1.5
Bajo pedido M20x1.5
Sob encomenda M20x1.5

VERSIONI SPECIALI
SPECIAL VERSION
SONDERAUSFÜHRUNG
VERSION SPECIALE
VERSIÓN ESPECIAL
VERSÕES ESPECIAIS

Su richiesta
On request
Auf Anfrage
Sur demande
A petición
Sob encomenda

ALTRE CARATTERISTICHE
OTHER FEATURES
ANDERE EIGENSCHAFTEN
AUTRES CARACTÉRISTIQUES
OTRAS CARACTERÍSTICA
OUTRAS CARACTERÍSTICAS

Morsettiera integrata, ingresso cavi orizzontale, soppressore picchi di tensione, doppia guarnizione, condizioni ambientali estreme
Integrated terminal block, horizontal cable entry, surge suppressor, double gasket, extreme environmental conditions
Integrierte Klemmleiste, horizontale Kabeleinführung, Überspannungsschutz, doppelte Dichtung, extreme Umweltbedingungen
Bornier intégré, entrée de câble horizontale, sur-tension, double étanchéité, conditions environnementales extrêmes
Bloque de terminales integrado, entrada de cable horizontal, supresor de sobretensiones, doble cierre, condiciones ambientales extremas
Bloco terminal ntegrado, entrada de cabo horizontal, supressor de pico de tensão, dupla vedação, condições ambientais extremas

CONNETTORE

CONNECTOR
STECKER
CONNECTEURS
CONECTOR
CONECTOR

 **22 mm**

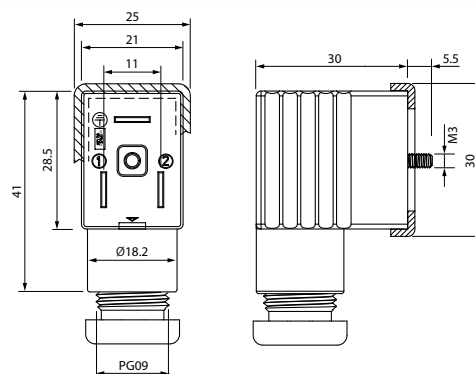
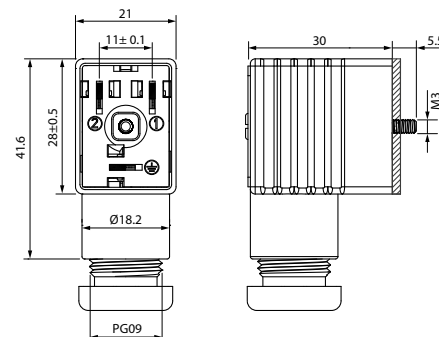

Codice Code Code Code Código Código	Taglia Size Größe Dimensions Talla Tamanho	Colore Colour Farbe Couleur Color Cor	Caratteristiche Characteristics Eigenschaften Caractéristiques Características Características
	mm		
CON01 000 01	22	BLACK	2 POLI - PINS - PINS - BROCHES - PINS - PINOS
CON02 024 00	22	TRANSPARENT	● LED + VDR 0 - 24V
CON02 110 00	22	TRANSPARENT	● LED + VDR 110V
CON02 250 00	22	TRANSPARENT	● LED + VDR 220V
CONU1 000 01	22	BLACK	2 POLI - PINS - PINS - BROCHES - PINS - PINOS

UL 1977 AND CAN/CSA C22.2 NO. 182.3

VDR: Dotati di Varistore come dispositivo di protezione delle sovratensioni.
Fitted with varistors as surge protection device.
Ausgestattet mit Varistor als ÜberSpannungsschutz.
Equipé avec varistance de protection contre les sur Tensions.
Dotado de Varistor como dispositivo de protección de sobretensiones.
Dotados de Varistor como dispositivo de proteção de sobretenção.



Schema elettrico
Wiring
Elektroschema
Schéma électrique
Esquema eléctrico
Esquema elétrico

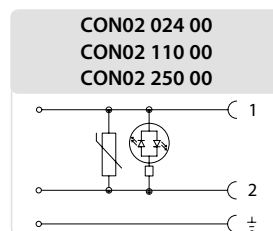
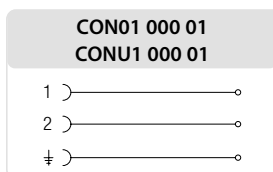

CONNESSIONI ELETTRICHE
ELECTRICAL CONNECTIONS
ELEKTRISCHE ANSCHLÜSSE
CONNEXIONS ELECTRIQUES
CONEXIÓN ELÉCTRICA
CONEXÕES ELÉTRICAS

FORM B - INDUSTRIAL
EN 175301-803
(EX DIN 43650)

GRADO DI PROTEZIONE
PROTECTION DEGREE
SCHUTZART
DEGRÉ DE PROTECTION
GRADO DE PROTECCIÓN
GRAU DE PROTEÇÃO

IP67
IEC 60529

DIAMETRO CAVO
CABLE DIAMETER
KABELDURCHMESSER
DIAMÈTRE DU CABLE
DIÁMETRO CABLE
DIÁMETRO DO CABO

6 ÷ 8 mm

CONNETTORE

CONNECTOR
STECKER
CONNECTEURS
CONECTOR
CONECTOR

 **30-36 mm**

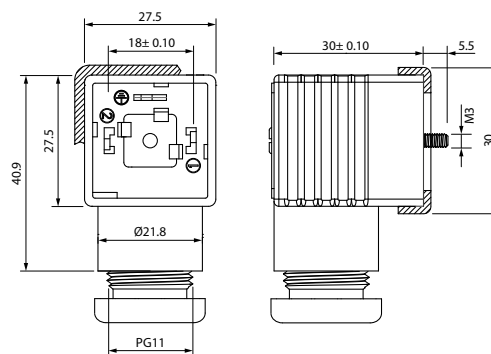
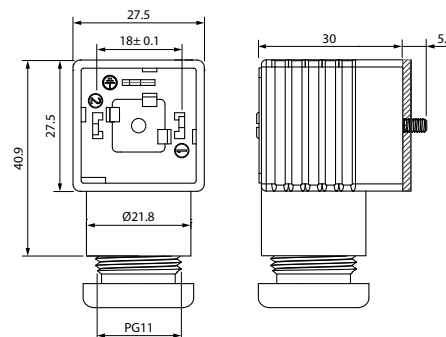

	Taglia Size Größe Dimensions Talla Tamanho	Colore Colour Farbe Couleur Color Cor	Caratteristiche Characteristics Eigenschaften Caractéristiques Características
	mm		
CON31 000 01	30 - 36	BLACK	2 POLI - PINS - PINS - BROCHES - PINS - PINOS
CON32 024 00	30 - 36	TRANSPARENT	● LED + VDR 0 - 24V
CON32 110 00	30 - 36	TRANSPARENT	● LED + VDR 110V
CON32 250 00	30 - 36	TRANSPARENT	● LED + VDR 220V
CONU3 100 01 	30 - 36	BLACK	2 POLI - PINS - PINS - BROCHES - PINS - PINOS

UL 1977 AND CAN/CSA C22.2 NO. 182.3

VDR: Dotati di Varistore come dispositivo di protezione delle sovratensioni.
Fitted with varistors as surge protection device.
Ausgestattet mit Varistor als ÜberSpannungsschutz.
Équipé avec varistance de protection contre les sur Tensions.
Dotado de Varistor como dispositivo de protección de sobretensiones.
Dotados de Varistor como dispositivo de proteção de sobretenção.



Schema elettrico

Wiring

Elektroschema

Schéma électrique

Esquema eléctrico

Esquema elétrico

CON31 000 01
CONU3 100 01

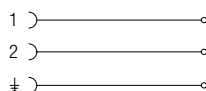

CON32 024 00
CON32 110 00
CON32 250 00

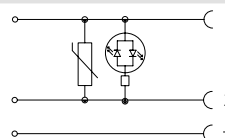

CONNESSIONI ELETTRICHE
ELECTRICAL CONNECTIONS
ELEKTRISCHE ANSCHLÜSSE
CONNEXIONS ELECTRIQUES
CONEXIÓN ELÉCTRICA
CONEXÕES ELÉTRICAS

FORM A

EN 175301-803
(EX DIN 43650)

GRADO DI PROTEZIONE
PROTECTION DEGREE
SCHUTZART
DEGRÉ DE PROTECTION
GRADO DE PROTECCIÓN
GRAU DE PROTEÇÃO

IP67
IEC 60529

DIAMETRO CAVO
CABLE DIAMETER
KABELDURCHMESSER
DIAMÈTRE DU CABLE
DIÁMETRO CABLE
DIÁMETRO DO CABO

6 ÷ 8 mm
&
8 ÷ 11 mm